

UPS WEB/SNMP MANAGER

CS121 Series

Additional Components (CS121 Extensions)

User Manual – English

Copyright Statement for Intellectual Property and Confidential Information

The information contained in this manual is non-conditional and may be changed without due notice. Although Generex has attempted to provide accurate information within this document, Generex assumes no responsibility for the accuracy of this information.

Generex shall not be liable for any indirect, special, consequential, or accidental damage including, without limitations, lost profits or revenues, costs of replacement goods, loss or damage to data arising out of the use of this document

Generex the manufacturer of the BACS products undertakes no obligations with this information. The products that are described in this brochure are given on the sole basis of information to its channel partners for them to have a better understanding of the Generex products.

Generex allows its channel partners to transfer information contained in this document to third persons, either staff within their own Company or their own customers, either electronically or mechanically, or by photocopies or similar means. Generex states that the content must not be altered or adapted in any way without written permission from Generex.

It is agreed that all rights, title and interest in the Generex's trademarks or trade names (whether or not registered) or goodwill from time to time of Generex or in any intellectual property right including without limitation any copyright, patents relating to the Products, shall remain the exclusive property of Generex.

Generex will undertake to deal promptly with any complaints about the content of this document. Comments or complaints about the document should be addressed to Generex Systems GmbH.

Copyright of the European Union is effective (Copyright EU).

Copyright (c) 1995-2015 GENEREX GmbH, Hamburg, Germany. All rights reserved.

English Manual

Dieses Handbuch ist auch in Deutsch verfügbar!

Eine aktuelle Kopie erhalten Sie unter Download bei www.generex.de.

This manual is also available in German!

To obtain an actual copy please see the download-page of www.generex.de

English Manual	2
1. The CS121 Family - Introduction	6
1.1 About your CS121	6
1.1.1 General Information	6
1.2 CS121 Device Type Overview	6
1.3 Scope of Delivery	8
1.4 Functional Overview of the CS121	8
1.4.1 Functionalities of your CS121	10
1.5 The Communication with the CS121-Adapter	11
1.6 CS121 Overview of the Connections and LEDs	12
2. Quickstart	14
3. Initial Operation of the CS121	14
3.1 Connect your CS121 ...	14
3.1.1 ... via LAN	14
3.1.2 ... via serial port	15
3.2 Verifying the CS121 Connectivity	15
3.3 Setup of the Basic Network Configuration	15
3.3.1 DHCP – Obtain an IP address automatically	16
3.3.2 Establishment of a static CS121 IP address manually (default delivery state)	16
3.3.3 Using HTTP/Webbrowser	17
3.3.4 Configuration using Telnet / MS-HyperTerminal	18
3.3.4.1 Main Menu & IP-Settings	18
3.3.4.2 UPS Settings	19
3.3.4.3 Saving Configuration	20
3.4 CS121 Restart and Boot Procedure	21
4. Configuration of the CS121	21
4.1 CS121 Menu System & Network Status	21
4.2 CS121 Menu “Configuration”	23
4.2.1 Saving Data	23
4.2.2 UPS Model & System	23
4.2.3 Network & Security	24
4.2.4 The CS121 with DHCP utilization	26
4.2.5 The CS121 with ICMP Check	26
4.2.6 Function hide of HTTP links	27
4.2.7 Configuration Static ARP Entries	27
4.2.8 Email	27
4.2.9 Email Trap	29
4.2.10 Email Trap Configuration	30
4.2.11 Timeserver	31
4.2.12 Language	32
4.2.13 Events / Alarms	33
4.2.13.1 Threshold Events	34
4.2.13.2 Logfile Entries	35
4.2.13.3 Email-Job	36
4.2.13.4 Email-To-SMS	36
4.2.13.5 AUX-Port	37
4.2.14 SNMP	38
4.2.15 COM2 & AUX	39
4.2.15.1 COM2	39
4.2.15.2 AUX and SITESWITCH4 Settings	43
4.2.16 SENSORMANAGER	43
4.2.17 RAS Configuration	44

4.2.18	Scheduled Actions	45
4.2.19	Save Configuration / Reboot	46
4.3	Reading the Logfiles	46
4.4	RCCMD	49
4.4.1	RCCMD Jobs	49
4.4.2	RCCMD Traps	50
4.4.3	RCCMD Shutdown	52
4.4.4	Automatic Reset of the Redundancy Alarm	56
4.4.5	RCCMD Message	57
4.4.6	RCCMD Execute/Command	57
	Example of use 1: CS121-adapter as RCCMD-listener	57
	Example of use 2: CS121-adapter switches an output	57
4.4.7	UPS shutdown	59
4.4.8	Wake On LAN (WOL)	59
4.4.9	Scheduled Actions	60
4.4.10	CS121 for Transfer Switches	60
5.	Adapter Software Updates (Firmware)	62
5.1	Firmwareupdate via Setup-tool	62
5.2	Firmwareupdate via FTP	62
5.3	Firmware flash renewal and recovery	63
5.4	How to get the "upsman.cfg" from a CS121 to your computer via FTP	63
6.	Additional Software	66
6.1	RCCMD	66
6.1.1	RCCMD with SSL for Windows	66
6.1.2	RCCMD with own SSL certificates	68
6.1.3	RCCMD client as relay station	68
6.1.4	License regulations	69
6.2	jChart	69
6.3	gChart	71
6.4	UPS monitor (UPSMON)	73
7.	CS121-Enhancements, Field of applications	74
7.1	SiteSwitch4 (SS4) and SiteSwitch4AUX (SS4AUX)	74
7.1.1	SS4 Feature overview	75
7.1.2	SS4 Contents	75
7.1.3	SS4 Installation	75
7.1.4	SS4 - Technical data	76
7.2	Sensor SM_T_COM	76
7.2.1	SM_T_COM configuration	77
7.3	SENSORMANAGER & SENSORMANAGER II	79
7.3.1	General information	79
7.3.2	Installation and Network integration	80
7.3.3	Special features of theSENSORMANANAGER II	83
7.3.4	Configuration	83
7.3.5	Alarm Matrix of the SENSORMANAGER II	84
7.4	RASMANAGER	86
7.5	GSM Modem – Notification via SMS	86
7.6	LED-Matrix Display	89
7.7	MODBUS/PROFIBUS/LONBUS	89
7.8	UNMS (UPS-Network Management System)	90
7.9	SNMP	91
8.	Troubleshooting – FAQ	92
8.1	Common Problems	Error! Bookmark not defined.

A.	CS121 - Technical data	100
B.	CE- and UL-Certification	100
C.	Cable and Circuit board configuration, Pin/AUX-Ports, SensorMan	100
D.	CS121 WDP – Watchdog & Powermanager	104
E.	MODBUS Interface	105
	E.1. General information	105
	E.2. Available Modbus Function Codes	106
	E.3. Exception Codes	107
	E.4. MODBUS Modes in the CS121 M (ASCII and RTU)	107
	E.5. UPS Parameter	108
	E.6. UPSMAN Status Bytes - Standard Device Status Bits	130
	E.7. Bus termination	131
	E.8. Configuration	132
	E.9. TCP/IP - UDP Ports	132
	E.10. MODBUS Cables	133
F.	Available Variables of the CS121	133
G.	Pin layout of Input-sockets of the SENSORMANAGER unit	134
H.	Events/Alarms of the CS121 – Description of the alarms	135
I.	Description of the alarms for single-phase UPS	138
J.	Configuration of Microsoft SCOM 2007 as CS121 Trap Receiver (Monitor)	140
K.	DHCP Configuration via Telnet	148
L.	RARITAN Dominion PDU Configuration	149
	Table of figures	153

1. The CS121 Family - Introduction

1.1 About your CS121

1.1.1 General Information

The CS121-series are a group of products designed especially for critical resource management within technical facilities. All of these products share many of the same basic CS121 features, and some have special components and functions.

The CS121 products are most commonly used for the management of UPS systems, get UPS data via SNMP and display all available data and failures. These information will be forwarded to desired clients. In addition a shutdown of these clients could be executed via our RCCMD Multi-Server Shutdown Software.

This user manual describes the main function of the CS121 and the function of additional components.

The construction and the configuration of the CS121 devices are universal. The adaption has to be fit in different UPS devices from worldwide located manufacturers. This user manual cannot show all alternatives. Different screenshots and described details have to be interpreted correspondingly.

1.2 CS121 Device Type Overview

The following CS121 device types are available as:





- external adapter
- slot card adapter

Devices	Function	Description
CS121L	SNMP-Adapter	external adapter with AC/DC converter power supply
CS121SC	SNMP-Adapter	Slot card adapter for chinese UPS
CS121F	SNMP-Adapter	Slot card adapter for FUJI UPS, Japan
CS121R	SNMP-Adapter	Slot card adapter for PILLER/CTA/RIELLO/AROS UPS, Italy
CS121MOD	SNMP-Adapter	External adapter with MODBUS interface (RS485)
CS121CS MOD	SNMP-Adapter	Slot card adapter with MODBUS interface (RS485)
CS121BL	SNMP-Adapter	External adapter BUDGET model (without COM2- and AUX port)
CS121BSC	SNMP-Adapter	Slot card adapter BUDGET model (without COM2- and AUX port)

And the following external devices, which are CS121 based, but got additional features.

Devices	Function	Note
SITEMANAGER	SNMP-Adapter + monitoring of sensors und actuators	GSM Modem connection possible
SITEMONITOR	SNMP-Adapter + monitoring of digital inputs	GSM Modem connection possible
SITESWITCH4	SNMP-Adapter + switching of power outlets	
BACS	SNMP-Adapter + monitoring of battery system	

Properties of the CS121 device types:

CS121 MODELS	FEATURES and OPTIONS	Supported UPS models	CS121 COMMON FEATURES FOR ALL MODELS *
<p>CS121L external</p> 	<p>Second mini din 9 COM port for RS232. AUX port for digital input/output. MODBUS RS485 option. Remote RAS management options.</p>	<p>All 1400 UPS models from over 80 different UPS manufacturers.</p>	<p>All these CS121</p> <ul style="list-style-type: none"> • devices are capable of managing the UPS models for which they are compatible via the UPS's native serial protocol. Each CS121 integrates seamlessly into all contemporary SNMP facility management systems.
<p>CS121SC slot</p> 	<p>Like CS121 L external, with CS121 WDP (see Appendix D.)</p>	<p>All Chinese/ Taiwanese standard slot UPS models.</p>	<ul style="list-style-type: none"> • models have their own web server with configurable event management for automating responses to power and UPS status conditions. This includes Emails transmission, RCCMD net work messages and shutdowns, logfile entries, grafical logfile for statistics, UPS shutdown functions and wake-up calls for computers which have been shutdowned before (wake-on-lan).
<p>CS121F FUJI slot</p> 	<p>Second mini din 9 COM port for RS232. AUX port for digital input/output. Remote RAS management options.</p>	<p>FUJI UPS</p>	<ul style="list-style-type: none"> • may be configured individually for all actions and events
<p>CS121R Riello slot</p> 	<p>Like CS121 F.</p>	<p>Riello and Aros UPS</p>	<ul style="list-style-type: none"> • have a built-in scheduler for regular tasks like battery tests, battery calibration and UPS shutdown/restore.
<p>CS121BL BUDGET external</p> 	<p>Economic CS121 with LAN UPS management only. (No AUX port for dry contacts, no COM2 interface for modem or environmental sensors.</p>	<p>All 1400 UPS models from over 50 different manufacturer.</p>	<ul style="list-style-type: none"> • > 4MB include MODBUS-over-IP and an optional MODEM interface. • offer a COM2 for connecting environmental sensors or for connecting other products and software to manage the UPS.
<p>CS121BSC BUDGET slot</p> 	<p>Like CS121 BUDGET external, with CS121 WDP (see Appendix D.)</p>	<p>All Chinese/ Taiwanese standard slot UPS models.</p>	<ul style="list-style-type: none"> • have 2 years warranty and a free update period of 3 years. • are made in Germany.
<p>CS121 MiniSlot</p> 	<p>Like CS121 BSC plus COM2 Multipurpose Port</p>	<p>Minislots from Soltec, Voltronic and others</p>	

1.3 Scope of Delivery

The standard CS121-adapter package contains an SNMP-adapter unit with supporting hardware and software (note, that the Budget-models do not have all features.)

Optional is a mounting kit for wall and DIN Rail mounting available.

Product	Scope of Delivery				
	External power supply ¹	User manual on CD	Configuration cable ²	Mini-8 COM port (MODBUS via RS232)	Mini-8 COM port (MODBUS via RS485)
CS121L (External)	x	x		x	
CS121SC (Slot Chinese)		x		x	
CS121SCM (Slot Chinese)		x		x	x
CS121F (Slot FUJI)		x		x	
CS121R (Slot RIELLO/AROS)		x		x	
CS121LM (Extern)	x	x		x	x
CS121BL (Budget Extern) ³	x	x			
CS121BSC (Budget Slot Chinese) ³		x			

¹ For USA/CA UL: Supplied by NEC Class 2 Power supply only

² For the configuration via serial interface with terminal software and for the connection to additional devices, e. g. sensors

³ Configuration with network cable only

1.4 Functional Overview of the CS121

The CS121 is working with an integrated Simple Network Management Protocol (SNMP) software agent. This agent exchanges data with the UPS via “get” and “set” commands and forwards Trap Messages to desired receivers. This Trap Messages inform the user about critical situations of the UPS, e. g. a power failure. In addition the CS121 can trigger RCCMD (Remote Console Command) signals, messages, and shutdowns.

RCCMD is an additional single licensed software.

Otherwise the control of the UPS is possible, e. g. switching on bypass.

Functional Overview of the CS121 Professional

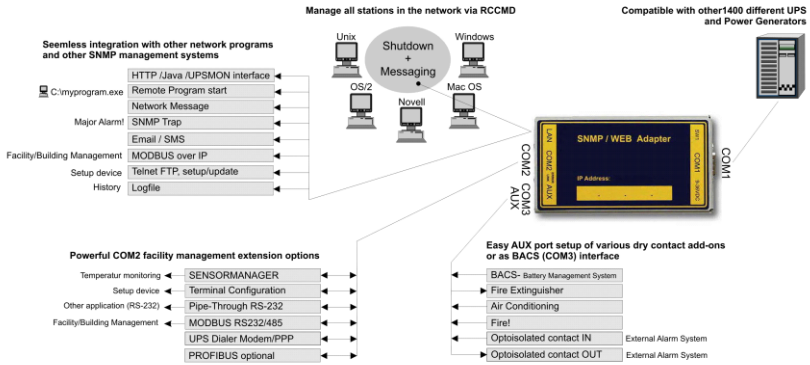

Functional Overview of the CS121 Budget

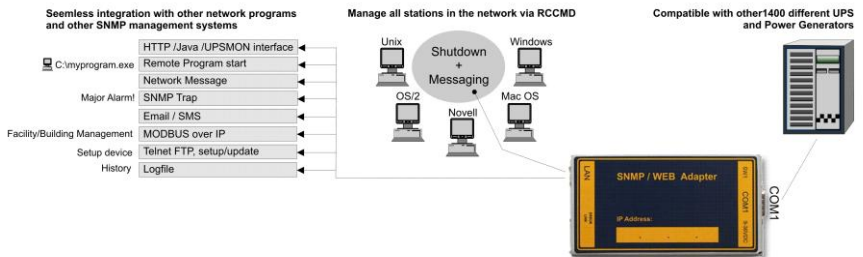

Functional Overview of the CS121 MINI

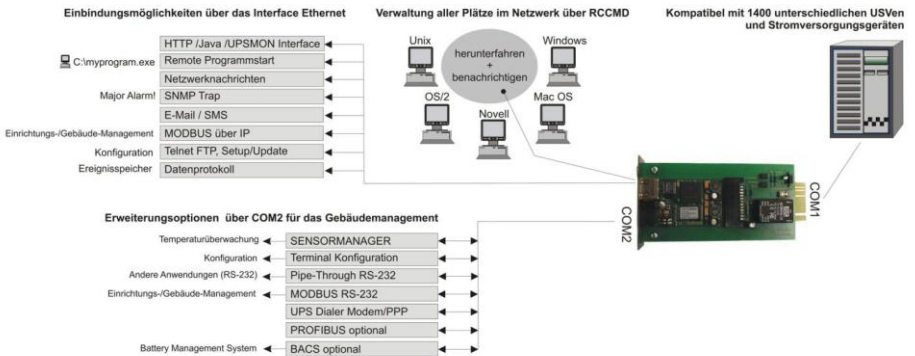

Functional Overview of the CS121_R_II

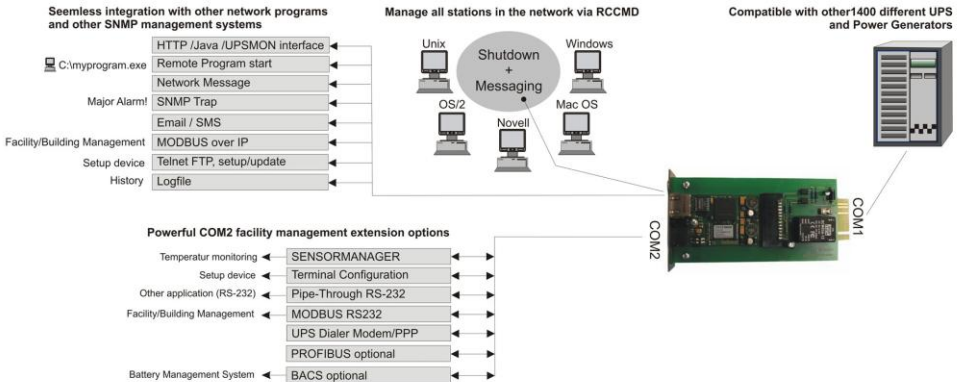

1.4.1 Functionalities of your CS121

- **SNMP Adapter CS121/CS121 Slot:** The SNMP adapter is a compact unit requiring minimal workspace (ca. 28x69x126 mm for the external adapter CS121L). The slot card versions of the adapter get inserted into the extension slots of UPS models supporting such a card type.
- **Serial Port:** Two DIP-switches change the adapter's serial port (COM2) to a configuration port for installation or to a communication port for environmental sensors, modem or other functions. The MODBUS-version uses the COM2 as RS485 interface and is not available for configuration. The MODBUS version can be configured via web-browser only, Telnet and default IP address.
- **SNMP-Traps for remote monitoring and pre-alarming:** The main function of the SNMP-adapter is the transmission of alarm conditions of the UPS to the monitoring station (SNMP traps and RCCMD traps/commands). It also makes UPS data for users in the network upon request available. With this function, it is possible to retrieve and monitor e. g. battery capacity of an UPS from a SNMP management station. The event settings configuration menu also allows for SNMP trap testing.
- **Remote Control:** With this function it is possible to switch the UPS to Bypass (depending on the model) or start battery tests. This remote command is executed either via the Network Management Station or the UPS Management Software or any web-browser.
- **Telnet:** Every Adapter can be reconfigured via the network, using Telnet or HTTP after the initial configuration of an IP address for the adapter. Current UPS data can also be shown using Telnet. Generally we recommend to use the web-interface, since Telnet (and terminal configuration) allows to setup a basic configuration of the CS121 only.
- **Works with all major NMS:** The CS121 works with most, widely used Network Management Systems, e. g. HP Open View HP UNIX and Microsoft Windows NT, Novell NMS, Spectrum, Sun NetManager, IBM Net View/600 and others. All SNMP systems, which either allow the compilation of the MIB or already incorporate MIB RFC 1628 for UPS Systems, can be used with the CS121.
- **Multiserver shutdown via RCCMD/RCCMD2 compatibility:** The CS121 is able to initiate a network shutdown with any RCCMD modules from the UPS-Management Software CD. A TCP/IP based RCCMD signal will be send to all RCCMD clients in the network. This enables the remote shutdown of practically an unlimited number of client computers, independent of the operating systems of the clients. RCCMD is an optional part of the UPS-Management Software. Your UPS dealer is able to provide you with license keys for the RCCMD Software. The UPSMAN service of the UPS-Management Software Suite is an optional module and not required for that basic CS121 operations. We recommend to use the UPSMAN service only, if

the UPS is connected via serial or USB cable, if a CS121 is connected, you just need a web-browser for the monitoring.

- **RS232 UPS Protocol Router – Pipe- through:** The CS121 (not BUDGET versions) is able to transfer the UPS RS232 protocol on COM1 directly to COM2. This allows the use of additional monitoring software on COM2, while making extra hardware (RS232 Multiplexer) to multiply the UPS comport unnecessary.
- **Log File:** The CS121 got an internal log file synchronized with either a timeserver in your network or from Internet timeservers. This log file can be accessed by web-browser, UPSMON, JAVAMON or via FTP. The size of the log file is 250 lines, older entries will be overwritten automatically.
- **Network Settings:** The CS121 models are adjustable to the network environment. An auto-sensing function, 10Mbit or 100Mbit can be selected.
- **Email Client:** The CS121 adapters incorporate a built-in SMTP email client, which is able to send emails automatically, if an error occurs.
- **Web-Server:** The CS121 models possess a web-server, which displays all functions and settings of the adapter. Non-Windows users may use the UPSView as graphically display for UPS data.
- **Network Connection:** The below figure displays a CS121 into a network environment. The CS121 is communicating with the UPS and displays all available data.

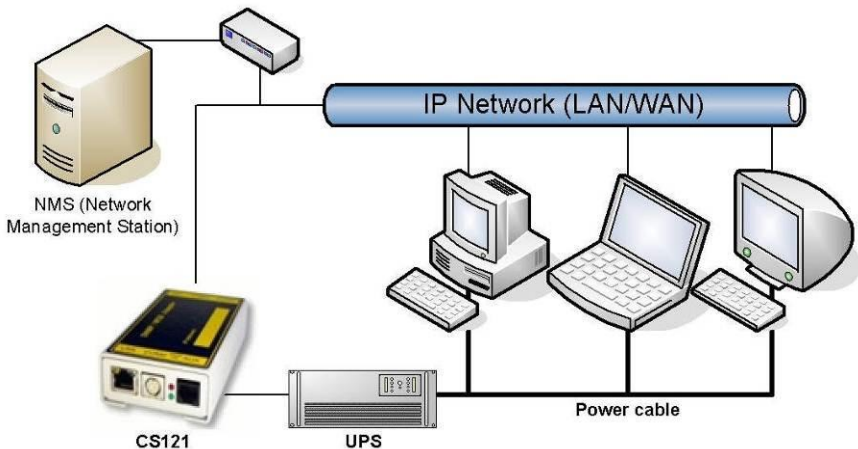

Figure 1: CS121 into a Network Environment

1.5 The Communication with the CS121-Adapter

• MODBUS

Modbus is the de facto standard protocol in industry, which is used in the facility management. All CS121 types include an MODBUS over IP interface and MODBUS over RS232. The CS121 MODBUS device types possess a RS485 interface at COM2.

• SNMP

The SNMP (Simple Network Management Protocol) is the Internet standard protocol for managing devices on IP networks and is defined and standardized in *Requests for Comments* (RFCs) specifications. Generally UPS systems are using the Management Information Base (MIB) with the RFC1628 specification, which defines UPS specific devices.

The CS121 also comes with the standard MIB RFC1628. Because of this MIB is already part of most SNMP software products, it is not required to compile the MIB (please search the MIB2

directory tree for a “UPS-MIB”). If you want to include your CS121 to a SNMP-Management station, which does not have the standard MIB RFC1628, you can download the specific MIB from our website http://www.generex.de/e/download/cs12x/download_p.html. Copy the MIB file to the appropriate MIB-directory of your SNMP-station and compile this file. In most cases your SNMP already has implemented this MIB and a compilation is only necessary, if you want to read extra information than just UPS (e.g. for SENSORMANAGER, etc.).

• **UPSTCP**

The most common way to communicate with the CS121 is over TCP. The CS121 contains UPSTCP, which gives you a complete interface to integrate the adapter into your network. If you are a software manufacturer, please contact us directly for the specification of this interface, if you want to implement it by your own. All others use TCP for the access via web-interface (UPSView, UNMS II) or SNMP or MODBUS.

1.6 CS121 Overview of the Connections and LEDs

For CS121 L, LM, SC, SCM and other slot cards:

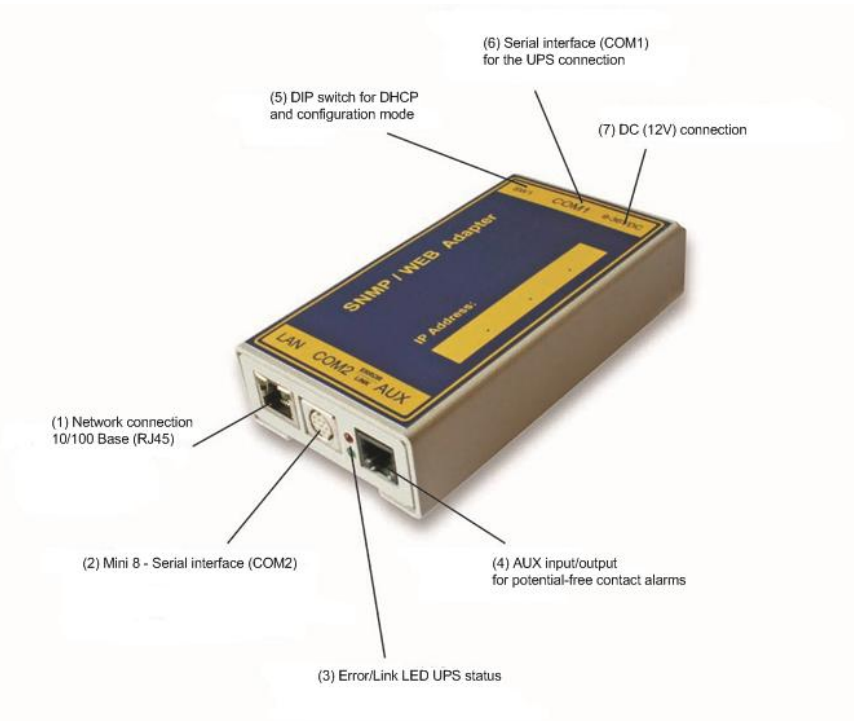

Figure 2: Connections of the CS121

- 1) **LED state of the network connection:** The LEDs of the RJ45 socket flashing green, if a network connection is established and yellow, if network communication is at present. The yellow LED displays the network traffic. If the yellow LED is glowing steady, the network traffic is too high.
- 2) **COM2 port** as Mini 8 connector for the configuration or connection of external devices.
- 3) **LED state of the CS121 HW 131:** The following tables are valid for the CS121 HW 131!

Green LED	Red LED	Adapter
OFF	ON	Adapter is looking for UPS/initializing. The start phase can last up to 3 minutes
Flashing	OFF	Data flow/normal mode of the UPS
ON	ON	Communication to UPS interrupted

Operating Condition CS121 HW 131	LED-Signaling
Start procedure 1, unpacking of the OS	red flashing, green off, if an error occurs, the red will glow steady
Start procedure 2, reboot of the OS	red long on
If the red and green LED shine at your CS121 HW131 during the reboot, huge broadcast traffic into your network is present „recieve buffer overflow“. The green LED is signaling at the reboot, that the „traffic buffer“ is full. Advice: You should filter broadcasts via your switch, because it comes to performance losing of the CS121 HW131 unnecessary.	red AND green during reboot
Normal condition	green flashing, displays the poll interval to the UPS
UPS communication lost	Red will glow steady

- 4) **AUX**, in- or output for potential-free contacts, relays
- 5) **DIP Switches**: The DIP Switches differ 2 functions; the configuration mode and the normal operation with optional DHCP.

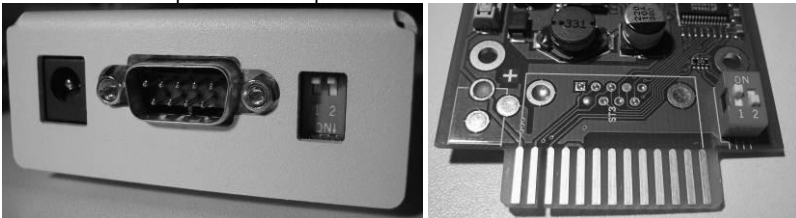

Figure 3: CS121L (left) in configuration mode (IP 10.10.10.10) and CS121SC (right) in normal mode

Switch 1	Switch 2	Description
ON	OFF	Normal operation, device runs on the configured IP-address
OFF	OFF	Configuration mode with default IP address 10.10.10.10 and active COM 2 configuration for Terminal software



Note: Into configuration mode the full functionality of the CS121 is not available! Please change to a valid network address and put DIP-switch 1 to position ON as soon as you made your basic network settings! After this, please continue configuring your CS121 in your network. Please follow up the procedure in chapter **Error! Reference source not found.** **Error! Reference source not found.** in this manual.

Please note, that the CS121 Budget versions got no COM2 port!

6) **Serial interface (COM1):** For the connection to the UPS



Note: UPS interface cable (external devices only): Please use the manufacturer's serial port cable that came with your UPS to connect the UPS with the SNMP-adapter. Please contact your UPS manufacturer, if you have questions. **Only use the original RS232 UPS cable for communication, which was provided with the UPS.** If your UPS has a contact closure port, please use the manufacturer's special cable. Please consult your UPS dealer for further information regarding special cables.

7) **Power supply,** the external CS121 got an external power supply (9 – 12VDC)



Note: If you are using a different power supply unit from the one in the adapter package, please consider that the polarity is set correctly. The adapter might be damaged if the wrong polarity is used. The power supply voltage should be at least 9V, 12 V is recommended.
For the CS121SC models C and the slot card, there are no power supply units. These units will receive power directly from the UPS device. The SNMP adapter C and slot card both incorporate a variable 9-36V input.

2. Quickstart

This quickstart describes the basic functions and settings of the CS121. The CS121 can be configured via Telnet, Terminal and HTTP. The Telnet configuration uses the same network interface as the HTTP configuration. The Terminal configuration requires a serial connection to a workstation.

We recommend the configuration via HTTP, because it is the most comfortable one and that is why we describe the HTTP configuration in this user manual.

After you finished the CS121 hardware setup, all 3 configuration modes are at present. If you want to use the Telnet or HTTP configuration, it is required to add a temporary network route to the CS121 configuration mode IP address 10.10.10.10.

Please use the following access data:

User: admin

Password: cs121-snmp

3. Initial Operation of the CS121

3.1 Connect your CS121 ...

In generally you can select between 3 ways to configure the CS121:

- You can execute the HTTP configuration via web-browser.
- You can execute the Terminal configuration via web-browser.
- You can execute a Terminal configuration via the serial interface (CS121 device types with a COM2 port only) with the CS121 configuration cable (optional, not included). This configuration-mode allows you to make the basic settings for the network connectivity and for the configuration of the event and alarm settings.

3.1.1 ... via LAN

Connect the CS121 with RJ45 cable (not included) to your LAN.

3.1.2 ... via serial port

The CS121 contains two serial ports (not BL and BSC-versions), COM1 provides the connection to the UPS and COM2 is used for the configuration of the SNMP adapter.

Configuration cable (not included):

With the configuration cable you could connect the serial port (COM2) of the CS121 and the serial port of a workstation with terminal software. It is sufficient to use a Dumb-Terminal or Terminal emulation program, such as e. g. Microsoft-HyperTerminal. Please ensure during the configuration of the CS121, that the DIP switches are into position OFF.

CS121 MINI/CS121 R_II:

It is required, that the DIP Switch 2 remains in position OFF, otherwise the device will not start (valid for CS121Minislot/CS121R_II built 2008- 2010 from serial number 0123M-0001 to 0123M-1135).

3.2 Verifying the CS121 Connectivity

After the CS121 is connected to the UPS and to the workstation via serial port or via LAN, please verify the connectivity before you start to configure the CS121. The setup system can be checked before and after a configuration using the following 3 steps:

- **UPS Status Displays (LEDs)**

During the boot procedure, the red LED is on, whereas the green LED is off, please take a look into chapter 1.6 for the complete signaling.

After five to ten seconds after the boot-process, the green LED flashes rapidly; this indicates that the SNMP-adapter is trying to start the communication. The adapter will indicate its communication accessibility with random green LED flashes.

- **Network status LEDs**

The LEDs, integrated into the LAN-Connector (RJ45-), will signal a connection to the network with green and with yellow network connectivity.

- **CS121 Ping Echo**

Perform a PING command from the SNMP station or from another workstation in your network.

If you do not get a response, check the CS121 network connection and IP address. The IP address of the adapter is set to 10.10.10.10, if DIP Switch 1 is in position OFF (configuration mode).



Note: The different response rates during the ping process do not correspond to an error. The CS121 does not answer every ping signal at the same time, due to different sized UPS protocols. If UPS protocols are of extensive size a temporary timeout can occur. A permanent timeout however is an error.

3.3 Setup of the Basic Network Configuration



Note: We recommend the following settings for the operation of the CS121 via cross cable (Ethernet cable for the connection directly). Set the IP address of the workstation with a cross cable to an IP address of the same network segment, e.g. 10.10.10.11 AND set the gateway to 10.10.10.10.

A network cross cable is a PC-PC network cable, which does not require a switch or a hub between 2 network workstations (2). Most modern workstation network cards have an auto detection, so any network cable may be used. Only if you do not have such a cable, connect a switch or Hub between your workstation and the CS121 (1).

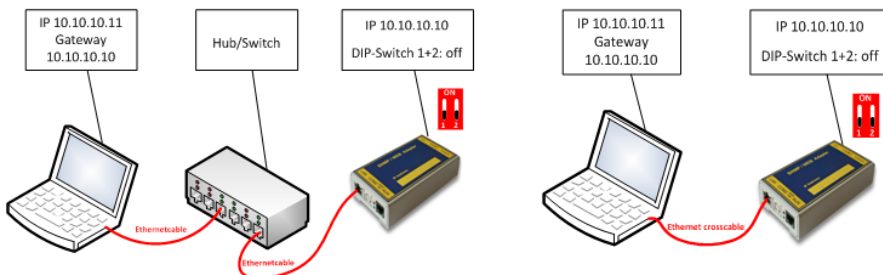

Figure 4: Connection PC-Switch/Hub and CS121 (2) Connection PC-Cross Cable/Network Cable and CS121

3.3.1 DHCP – Obtain an IP address automatically

By default DHCP is off at all CS121. From CS121 FirmWare Version 4.25.x you can switch on DHCP via DIP switch 2 manually. Therefore the CS121 will get a DHCP IP address from the DHCP server during reboot. Prior of that, you should detect the MAC address of the CS121 to be able to find the IP address on your DHCP server. You can also use the GENEREX Netfinder tool (<http://www.generex.de/generex/download/software/install/NetFinder.zip>). This tool searches all CS121/BACS devices into your network environment. **We recommend to use static IP addresses, because the CS121 is used for multi server shutdowns via RCCMD too and it might be, that the DHCP server got a breakdown.** For that reason the delivery default of the CS121 is always with DHCP OFF!



Note: The function DHCP ON/OFF is valid for the following models only: all CS121 HW 131 and all BACS II Webmanager Budget (not valid for all CS121 HW 121, SiteManager, SiteMonitor, MiniSlot, CS121_RII and Pillar I/O Board)!

3.3.2 Establishment of a static CS121 IP address manually (default delivery state)

The minimum requirement to operate the SNMP-adapter is to set the IP address, subnet mask and the UPS model:

- The DIP-switches of the SNMP-adapter firstly need to be set for the configuration. DIP-switch 1 is switched OFF in the top position as well as DIP switch 2 is switched OFF.



Note: For slot versions you have to insert and remove the device for any reboot-process. This will not have any effect on your UPS but we recommend doing such operations only when the UPS is not supplying any load!

- As soon as the network-LED is flashing, add a TCP/IP route on your computer for IP-address 10.10.10.10. This is done via a call from your command line e.g. "route add 10.10.10.10 <your computers IP address>". See also route -? for more help of route syntax.
- Test if you can ping the device now: Enter command „ping 10.10.10.10" and check if there is any response. Now you can connect with any Telnet or HTTP-software and continue with the configuration.

3.3.3 Using HTTP/Webbrowser



Attention! Please finish all configuration menus via “Apply” button. After you finished your whole configuration, please note, that it is required to execute the “Save, Exit & Reboot” function via CS121 menu “Save Configuration”.

The entire configuration can be done via Webbrowser. Please use the default IP-address 10.10.10.10 and the TELNET password (**default: “cs121-snmp”**). The username is always “admin”.

Please do never close the web-browser or telnet window during saving process! If you close the configuration window too early, you might destroy the configuration file “upsman.cfg”.

Please note, that the reboot process could last up to 3 minutes.

For the configuration using the webbrowser please observe the following:

We recommend the use of Microsoft Internet Explorer 6.x (or higher) or Mozilla 1.3x. Please note, that Java scripting has to be activated. Using Internet Explorer, the corresponding settings have to be made under “Internet options” - “security”.

We also recommend never to use the history function of the browser, as this may lead to multiple transfer of commands (e.g. delete event jobs) to the adapter.

Upon entering a HTTP-configuration session, the user is required to enter a username, “admin”, in addition to the password “cs121-snmp”.

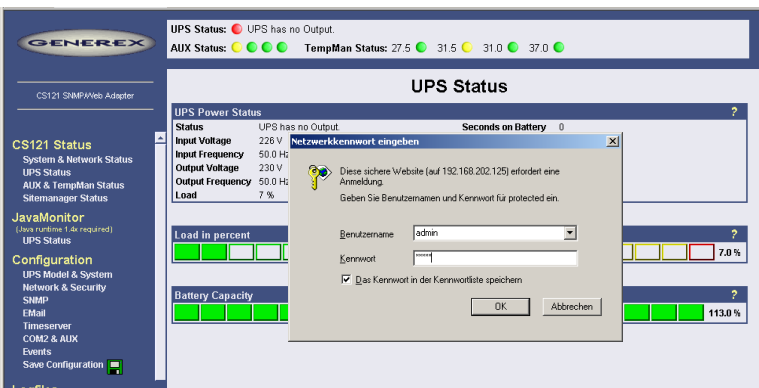

Figure 5: HTTP - Administrator login



Note: If the HTTP-method does not seem to be available, check to see whether or not the red LED UPS Status glows.

► Call Configuration, “UPS Model & System” and choose your UPS Model from the drop down list. Further configurations like Power, baud rate, cable type etc. were made automatically (ensure your Browser has enabled JavaScript) and do not need to be set. We strongly recommend to keep the default settings for this UPS unless you have instructions from the UPS maker.

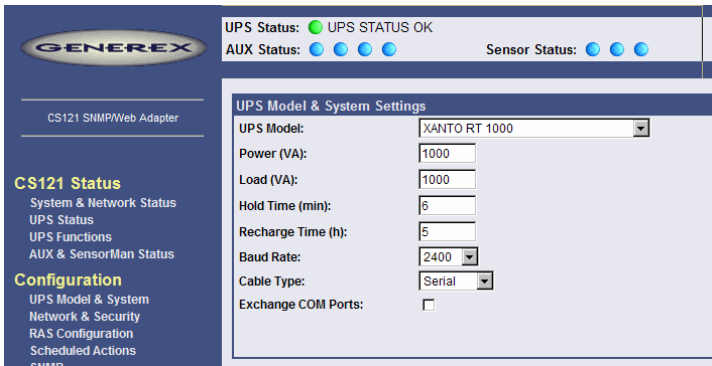

Figure 6: HTTP - UPS Model & System Settings

- ▶ Apply your settings with the button at the right side.
- ▶ Change to menu "Network & Security" and specify IP-address, Gateway and Subnet Mask to the CS121-adapter.

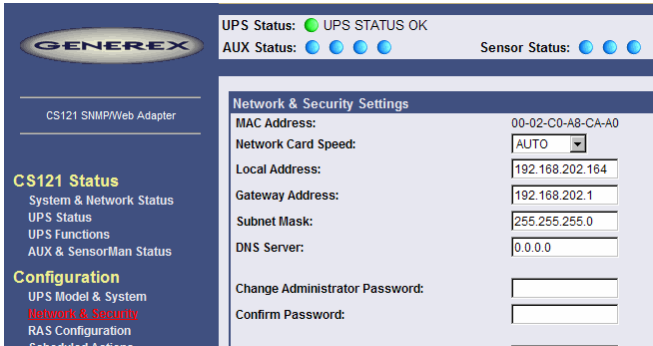

Figure 7: HTTP - Network & Security Settings

- ▶ Apply your settings with the button at the right side.
- ▶ Change to menu "Save Configuration" and click "Save Configuration".

3.3.4 Configuration using Telnet / MS-HyperTerminal

Use of Telnet, enter the command: „telnet <IP-Address>“, whereas <IP-Address> is in the configuration mode set to 10.10.10.10. Please note, that since CS121 firmware version 4.x, the basic settings (IP address, network settings) are at present only.

3.3.4.1 Main Menu & IP-Settings

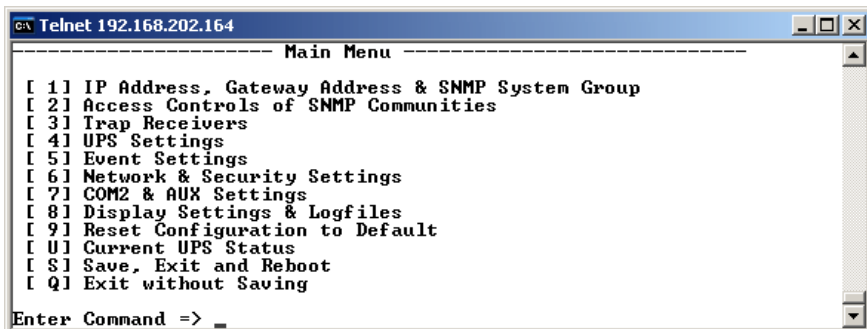
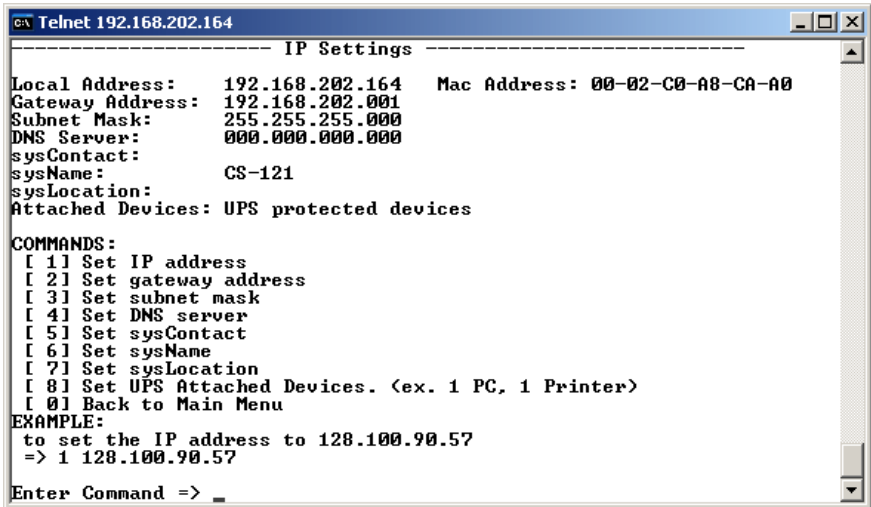

Figure 8: Telnet - Main Menu

To select any option in the main menu enter the number of the option at the Enter command => prompt. The program displays the desired screen.

▶ Type 1 at the prompt and you enter the menu "IP Settings". Within this menu you can enter basic network configurations, e. g. IP address, Gateway-address etc.



```

Telnet 192.168.202.164
----- IP Settings -----
Local Address: 192.168.202.164   Mac Address: 00-02-C0-A8-CA-A0
Gateway Address: 192.168.202.001
Subnet Mask: 255.255.255.000
DNS Server: 000.000.000.000
sysContact:
sysName: CS-121
sysLocation:
Attached Devices: UPS protected devices

COMMANDS:
[ 1] Set IP address
[ 2] Set gateway address
[ 3] Set subnet mask
[ 4] Set DNS server
[ 5] Set sysContact
[ 6] Set sysName
[ 7] Set sysLocation
[ 8] Set UPS Attached Devices. (ex. 1 PC, 1 Printer)
[ 0] Back to Main Menu

EXAMPLE:
to set the IP address to 128.100.90.57
=> 1 128.100.90.57

Enter Command => _

```

Figure 9: Telnet - IP Settings

To change values, enter the number of the option, type <space> and enter the name. Press <enter>. Your new value displays next to the field heading on the top of the screen. If you want to return to the *main menu*, press 0 (zero) and <enter>.

For example: To assign the IP-address of the SNMP-adapter, the gateway and the subnet mask type at the prompt:

1, <space>, the IP address of the SNMP adapter, <enter>

- ▶ Enter Command => 1 192.10.200.0
- ▶ Enter Command => 2 192.10.200.254
- ▶ Enter Command => 3 255.255.255.0

To assign the system contact name, type 5 and enter the name of the person to contact about the SNMP adapter.

- ▶ Enter Command => 5 Mr. Harry Hirsch

To assign the UPS name SysName, type 6 and enter name of the UPS:

- ▶ Enter Command => 6 USV 1

To assign the UPS location SysLocation, type 6 and enter the location name:

- ▶ Enter Command => 7 Building 12

3.3.4.2 UPS Settings

▶ Choose option 4 from the main menu and you enter the menu "UPS Settings". Within this menu the user needs to select the UPS model the CS121-adapter is connected to (usually at COM1).

```

c:\ Telnet 192.168.202.164
----- UPS Settings -----
[ 1] UpsModel      : XANTO RT 1000
[ 2] Location      :
[ 3] Power (UA)    : 1000      [ 4] Load (UA)      : 1000
[ 5] Hold time(m) : 6         [ 6] Recharge time(h): 5
[ 7] UpsID        : 0         [ 8] Baudrate       : 2400
[ 9] Battery Installation Date: 01.01.2005
[ D] System shutdown (minutes before battery end - downtime): 6
[ E] Exchange COM Ports: No
[ 0] Back to Main Menu.

COMMANDS:
  Enter 1 for a UPS-Model list.
  To enter a Model type 1 <modelnr>,ex.: 1 1 selects No UPS Model def
ined.
  To alter default parameters enter datafield number and value.
  ex.: 3 3000 sets Power to 3000UA
  ex.: 9 01.02.2002 sets Battery Installation Date to 1st of February
2002

Enter Command => _

```

Figure 10: Telnet - UPS Settings

The CS121-adaptor distinguishes here generally between Cable- and Serial-models. With Cable, the adapter and the contact interface of the UPS are connected with a special cable. Using Serial, UPS models connect to the adapter via the serial UPS-cable. (Part of the UPS package). Serial is default, when the user selects a UPS model name from the drop-down list. When Cable is used, please search the list for the corresponding UPS model and cable type.

The CS-121 supports serial models with its own RS-232 protocol as well as contact UPS models with the cable types O,C,1-10. Those contact cables are UPS or alarm system specific and should be provided by the corresponding manufacturer. Our Cable documentation shows examples of those cables if they are individually made cables.

Please choose the corresponding serial UPS model or cable model communication parameters. Parameters like baud rate etc. are present for the corresponding UPS model.



Note: By selecting the UPS model, the communication protocol is selected at the same time. If your UPS does not appear in the list, ask your UPS dealer if another model from the same series can be substituted.

▶ Select Option 1 to get a variety of possible UPS models. After chosen a model, the default values of the corresponding UPS model can be configured by typing the number of the option followed by the value.



Note: Please do not change parameters except of UPS-model unless you want to choose specified configuration according your UPS-model!

Please note option "D": "System shutdown (minutes before battery end – downtime)": This value determines how many minutes before a complete battery unload the event "System shutdown" from event menu is executed.

The shutdown time interval needs to be set large enough, so that adequate time for a system shutdown is allocated before the UPS runs out of power. Please calculate this value generously e.g. if the battery time of the UPS is 10 minutes and the event procedure takes 2,5 minutes, ensure you start (configure) the shutdown (or other event action) 3 minutes before the UPS is switched off, so that more than enough time is available to complete the corresponding event action.

3.3.4.3 Saving Configuration

▶ Call "Save, Exit and Reboot"-command from the main menu. (The communication to the adapter will be lost).

ATTENTION: Keep the Telnet, Terminal, web-browser window **open** until the device has been lost or you see a message that reboot is under progress. **If you close the configuration window too early it may corrupt the upsman.cfg configuration file.**



Note: Various options and settings for UPS-configuration can be done under Telnet or HyperTerminal, e.g. setting access controls of the SNMP-communities, set traps, set display settings, etc. However, the configuration via web-browser offers a much more convenient way to configure the CS121. If you have any possibility we recommend you to use this way.

3.4 CS121 Restart and Boot Procedure

► After you have finished the basic IP- and network-settings you should set DIP-switch 1 in position ON and restart the adapter with your configurations.

You can perform a CS121 restart by unplugging the power supply of the CS121 and wait, until the CS121 has restarted with your configurations.

Alternatively you can restart the CS121 with the “Reboot”-Option in the “Save Configuration”-menu of the web-browser. The following message will displayed:

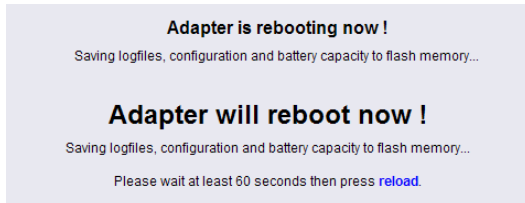

Figure 11: HTTP – Adapter reboot dialog

A successful restart of the adapter is indicated with the CS121 UPS- and network-LEDs as described in section 3.1 Connect your CS121

► Reconnect your web-browser with the adapter using the configured IP-address. (e.g. <http://192.168.10.123>)

Your CS121 is now ready for further configurations!



Note: If the adapter’s HTTP-service is not available, check to see whether or not a red Status-LED is lit. Further, test if you reach the adapter with a ping-command. Enter command „ping <IP-address>“. If the adapter doesn’t answer to the ping, check also whether your network routes the IP-address.

4. Configuration of the CS121



Note: After you have finished the basic network configuration you should have set DIP-switch 1 in position ON and rebooted the adapter. At the SC slot cards you have to remove the card from its slot and change the DIP Switch 1 to position ON. After this, re-insert the card. Info: There is no risk to remove/insert the slot card, there will be no effect on the UPS output.

4.1 CS121 Menu System & Network Status

The Menu “System & Network Status” shows basic information about general configuration settings.

System Info & Network Status

System Information			
CS121 Hardware	CS131	Location	
CS121 Firmware	CS121-SNMP v 4.17.12 090831	System Name	CS-121
	HyNetOS Rel. 2.4.1.32(pdv) - Aug 27, 2009 HTarget Server Rel. 2.4.1.15(pdv) - Aug 05, 2009 DRIVER Genexx CS123 Rel. 2.4.1.75(pdv) - Aug 29, 2008 Loader: BOOTCS123, ROM-Version: 2.3.131(pdv) - Jun 05, 2009 UPS driver: 714	System Contact	
UPS Manufacturer	Genexx	Attached Devices	UPS protected devices
UPS Model	smart offline UPS	System Time	02.09.2009 12:17:07
		Uptime	0 days 0 hours 10 minutes 3 seconds
		Total Uptime	Approx. 0 days 0.2 hours
		GSM Signal Quality	-109...-53 dBm
Network Status			
MAC Address	00-03-05-0E-07-19	Telnet Server	On
Network Speed	AUTO	HTTP Server	On
IP Address	192.168.222.186	Upsmon Server	On
Subnet Mask	255.255.255.0	Use RCCMD2 Traps	Yes
Default Gateway	192.168.222.100	SNMP Server	On
DNS Server	192.168.222.100	Use SNMP Coldboot Trap	No
E-Mail Server	not configured	Use SNMP Authentication Trap	No
Time Server	129.6.15.29	Modbus Server	On

Figure 12: HTTP – System & Network Status

The menu “UPS Status” gives information about the actual UPS-data, above all the state of charge and battery load:



UPS Status			
UPS Power Status ?			
Status	UPS STATUS OK		
UPS Model	XANTO RT 1000	Location	
Input Voltage	227 V	Seconds on Battery	0
Input Frequency	L1: 50.0 Hz L2: 0.0 Hz L3: 0.0 Hz	Battery Voltage	41.60 V
Output Voltage	230 V	Battery Capacity	100.0 %
Output Frequency	N/A	Autonomy Time	32.91 minutes
Load	27 %	UPS Temperature	27.6
Load in percent ?			
 27.0 %			
Battery Capacity ?			
 100.0 %			

Figure 13: HTTP – UPS Status

The menu “UPS functions” allows you to perform USV test- and control-scenarios like battery tests, etc. The UPS functions depend on the UPS type and its functions. Some UPS only allow a remote on/off, others have more functions.

UPS Configuration / Test / Control Functions	
<div style="border: 1px solid gray; padding: 5px;"> <p style="text-align: center;">UPS Configuration</p> <p>Enable Auto-Reboot <input checked="" type="checkbox"/> E D</p> <p>Enable Bypass if UPS off <input type="checkbox"/> E D</p> </div> <div style="border: 1px solid gray; padding: 5px; margin-top: 5px;"> <p style="text-align: center;">Enable / Disable Buzzer Action</p> <p>General off <input type="checkbox"/> E D</p> <p>Bypass operation <input type="checkbox"/> E D</p> <p>Battery operation <input type="checkbox"/> E D</p> <p style="text-align: center;">E/D the cancelling of buzzer by key control</p> <p>Bypass operation <input type="checkbox"/> E D</p> <p>Battery operation <input type="checkbox"/> E D</p> <p>Fault Log of UPS <input type="button" value="Receive"/> <input type="button" value="Show"/></p> </div>	<div style="border: 1px solid gray; padding: 5px;"> <p style="text-align: center;">Battery Tests</p> <p>Short Test <input type="button" value="Start"/> <input type="button" value="Cancel"/></p> <p style="text-align: center;">Batteries of UPS will be tested for some seconds!</p> <p>Custom Test <input type="text" value="3"/> Min. <input type="button" value="Start"/> <input type="button" value="Cancel"/></p> <p style="text-align: center;">Batteries of UPS will be tested for the time above!</p> <p>Long Test <input type="button" value="Start"/> <input type="button" value="Cancel"/></p> <p style="text-align: center;">Batteries will be tested until battery low appears!</p> </div> <div style="border: 1px solid gray; padding: 5px; margin-top: 5px;"> <p style="text-align: center;">Restart UPS</p> <p style="text-align: right;"><input type="button" value="Start"/> <input type="button" value="Cancel"/></p> <p style="text-align: center; font-size: small;">Attention: Power up reset of load is being carried out UPS OFF in 1 min. / UPS ON in 2 min.!</p> </div>

Figure 14: HTTP - UPS Functions for AEG UPS

The AUX & SensorMan status shows the actual measurements of the connected environmental sensor devices SM_T_COM, SM_T_H_COM, SENSORMANAGER, CON_AUX or CON_R_AUX.

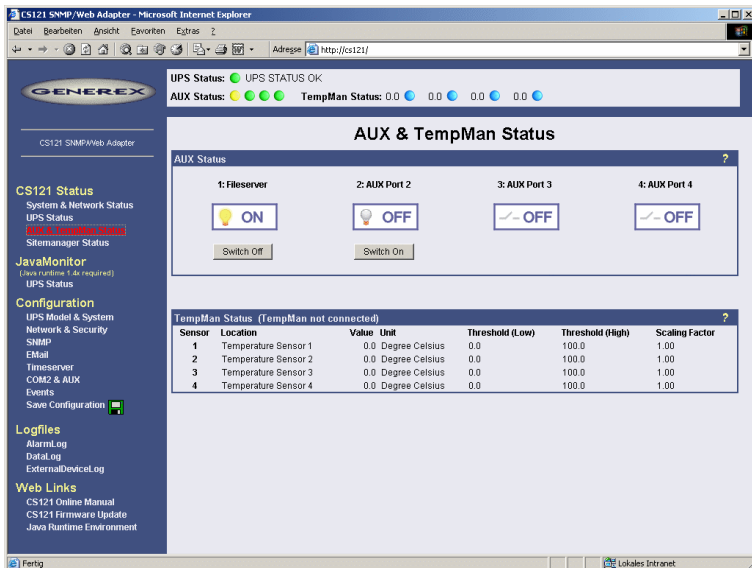

Figure 15: HTTP - AUX & SensorMan Status

In the above figure, a button menu is presented in which the ports 1 and 2 can be clicked on and off. A yellow light bulb indicates that output to the corresponding port is being provided, while the gray unlit light bulb indicates the status of being switched off in which case the connected device is not being provided with power. The buttons „Switch Off“ and „Switch On“ are password protected. This is the same password that has been set in the CS121-configuration. The ports 3 & 4 are configured as input sensors, here the OFF symbol shows an open contact, and alarm would show a closed contact. The AUX port of CS121 can be configured as output or input – or a mixture of both.

4.2 CS121 Menu “Configuration”

4.2.1 Saving Data

ATTENTION! The following is essential for all entries of configuration data:

- Close all web-browser menus via the “Apply” button.
- If you have finished your configuration completely, get into the CS121 menu Save Configuration and execute the “Save, Exit & Reboot” function.

IMPORTANT! Do not close the Telnet or web-browser window, until the connection to the host is lost or you got a message, that the CS121 is rebooting. **If you close this window too early, it might be, that you will damage the configuration file “upsman.cfg”.**

Please note, that the reboot process of the CS121 could last at least 3 minutes.

4.2.2 UPS Model & System

Use this menu to define the communication between the CS121 and your UPS.

UPS Model & System Settings			
UPS Model:	XANTO RT 1000	UPS ID:	0
Power (VA):	1000	System Name:	CS121
Load (VA):	1000	System Location:	Hamburg
Hold Time (min):	6	System Contact:	CS121-administrator
Recharge Time (h):	5	Attached Devices:	UPS protected devices
Baud Rate:	2400	Battery Installation Date:	01.01.2005
Cable Type:	Serial	System Shutdown Time:	6 minutes
Exchange COM Ports:	<input type="checkbox"/>		
<input type="button" value="Apply"/>			
Custom Values			
Custom Text 1:	<input type="text"/>	Custom Text 4:	<input type="text"/>
Custom Text 2:	<input type="text"/>	Custom Text 5:	<input type="text"/>
Custom Text 3:	<input type="text"/>	Custom Text 6:	<input type="text"/>
<input type="button" value="Apply"/>			

Figure 16: HTTP - UPS Model & System

With the parameters UPS ID, system name, system location, system contact you can describe the UPS and CS121.



Note: Do not change the default UPS-Parameters for Baud Rate and Hold time unless you have special instructions from the UPS maker.

Please note the field "System Shutdown Time": This value determines, how many minutes before a complete battery unload the event "System shutdown" from the event menu will be executed. **Attention:** This EVENT is the final task a CS121 can initiate, before the UPS switches off! DO NOT use this event for triggering shutdowns via RCCMD etc., because the remaining time in this status is not secure. We strongly recommend to use the event Powerfail and configure the RCCMD shutdown signals with a UPS "remaining time", this is the best way to send RCCMD shutdowns to several IP addresses in a certain logic or sequence!

The section „Custom Values“ contains 6 fields with can be used to save custom specific comments concerning your UPS.

4.2.3 Network & Security

Network & Security Settings			
MAC Address:	00-03-05-18-53-82	TCP MSS:	1460
Network Card Speed:	AUTO	Service & Update Port:	4000
Local Address:	192.168.222.208	Enable Telnet Server:	<input checked="" type="checkbox"/>
Gateway Address:	192.168.222.100	Enable FTP Server:	<input checked="" type="checkbox"/>
Subnet Mask:	255.255.255.0	Enable HTTP Server:	<input checked="" type="checkbox"/>
DNS Server:	0.0.0.0	HTTP Port:	80
Use DHCP:	<input type="checkbox"/> 0.0.0.0	HTTP Refresh Time:	10
Hostname:	<input type="text"/>	HTTP Default Page:	UPS Status
Force configured Gateway:	<input type="checkbox"/>	Enable HTTP Tooltips:	<input checked="" type="checkbox"/>
Use ICMP Check:	<input type="checkbox"/>	Hide HTTP Device Status Link:	<input type="checkbox"/>
	0.0.0.0	Hide HTTP Device Status Graphic Link:	<input type="checkbox"/>
	0.0.0.0	Hide HTTP Device Functions Link:	<input type="checkbox"/>
	0.0.0.0		
Change Administrator Password:	<input type="text"/>	Enable UpsMon Server:	<input checked="" type="checkbox"/>
Confirm Password:	<input type="text"/>	UpsMon Port:	5769
		Use RCCMD2 Traps:	<input checked="" type="checkbox"/>
Change UpsMon & S54 Password:	<input type="text"/> <input type="button" value="Clear"/>	Enable RCCMD Listener:	<input type="checkbox"/>
Confirm Password:	<input type="text"/>	RCCMD Listener Port:	6002
Use UpsMon Password for Web Pages:	<input type="checkbox"/>	RCCMD Timeout:	180
		Use RCCMD SSL:	<input type="checkbox"/>
System Name:	CS-121	Enable Modbus over IP:	<input checked="" type="checkbox"/>
System Location:	<input type="text"/>	Modbus Slave Address:	1
System Contact:	<input type="text"/>	Modbus Mode:	RTU
Attached Devices:	UPS protected devices		
RASMAN_G IP Address:	0.0.0.0		
RASMAN_G IP Port:	6000		
Auto-Update ARP Cache:	<input type="checkbox"/>		
<input type="button" value="Apply"/>			

Figure 17: HTTP - Network & Security Settings

This menu configures the CS121 network card settings, passwords and enable/disables several adapter and network services.



Note: We recommend to set the Network Card Speed *NOT* to “Auto”, but rather to the accordant speed of your switch. In addition we recommend to open the TCP/IP and UDP ports only, that the CS121 is using. Please take a look into the chapter Appendix D. To stabilize the CS121 in larger networks we recommend to close the update TCP Port 4000 at the CS121 configuration or at your switch. Please note, that you are not able to update the CS121 firmware anymore if port 4000 is disabled. Enable the port 4000 again, if you want to update the firmware.

The CS121 firmware version 4.30.x provides the definition of the TCP MSS value. The **Maximum Segment Size** defines the amount of bytes, which will be send as reference data into a TCP segment. The default is 1460. If you got problems with a VPN connection, change the TCP MSS value to 1100. The TCP MSS value is valid for HTTP only!

Enable RCCMD Listener: Among others, here you can allow the CS121 to act as an RCCMD listener client. This makes it possible for another UPSMAN-Manager, CS121, SITEMANAGER or other RCCMD compatible sender to send the adapter an RCCMD command like sending one of the AUX output ports a high or low signal or to start other actions.

You can also set the MODBUS configurations in this menu. The configuration requires only the following entries:

- **Enable Modbus over IP:** Every CS121 model can also transfer UPS data via the MODBUS-protocol on IP (port 502). You may use any MODBUS client to read the UPS value from CS121. For using the RS485 interface, you must use a CS121MODBUS (special hardware) in other cases you have to use MODBUS-over IP. This is enabled by default, you may disable this feature via Telnet or HTML-configuration.
- **Modbus Slave Address:** Enter the corresponding number, meaning which number in the chain (bus) the adapter is.
- **Modbus Mode:** RTU (binary mode) or ASCII mode text output. Please select the type with the scroll down menu.



Note: ASCII Mode works at CS131 & CS121 platforms with communication parameters 7/E/2, or 7/E/1 or with 7/N/2 from baudrate 1200 to 38400. We recommend for ASCII the use of 7/N/2 and the highest baudrate supported by your device.

RTU Mode works at CS131 & CS121 platforms with communication parameters 8/E/1 or 8/N/2 or 8/N/1 or 8/E/2 or 8/O/2 or with 8/O/1 from baudrate 1200 to 38400. We recommend for RTU the use of 8/E/1 and the highest baudrate supported by your device.

- **Change Administrator Password:** The password protects against unauthorized usage and manipulation. The default password is "cs121-snmp". In case you have "forgotten" your password a master password can be generated using your adapter serial number. Please contact your manufacturer for more information.
- **Change UPSMON & SS4 Password:** This is a separate password (default: "cs121-snmp") and allows to open UPS FUNCTIONS and SS4 FUNCTIONS only to specific users. With this password, which is valid for the TCP/IP connection to the UPSMON too, the user may switch on/off the UPS, start battery tests, switch SITESWITCH 4 outputs, but can not change any other setting on the CS121 configuration. Exception: If the administrator password (default identic) was not changed. The UPSMON is a Windows client, which is able to connect via network to the CS121. The UPSMON and SS4 password is used as protection. Advice: For the activation of the new password (apply button), it is required to reboot the CS121 via the „Save, Exit & Reboot“ function.

The CS121 firmware version 4.52.x provides the entry of a **Hostname**, if you want to use **DHCP**.

In addition the new feature **“Force configured Gateway”** is disabled by default. At disabled all requests will be responded to the requesting IP address and its MAC address directly. If enabled, all incoming requests will be routed through the defined Gateway exclusively.

4.2.4 The CS121 with DHCP utilization

The *firmware version 4.xx* and higher contains DHCP. With DHCP your CS121 will get an IP address automatically from the DHCP server. Please note, that this address allocation should be fixed, because RCCMD, which checks the addresses of the senders, will not be functional. Click the **“Network & Security”** button in the CS121 configuration and check the **“Use DHCP”** box.

Figure 18: HTTP - Network & Security DHCP Settings

Click the **“Apply”** button and reboot the CS121 with the **“Save, Exit & Reboot”** function.

Fallback address: If the DHCP server will not be available, just reboot the CS121 to use the fallback address. This address is equivalent to the settings of the local address in the menu **„Network & Security Settings”**. When DHCP will be available again, just reboot the CS121 to use the DHCP address.

4.2.5 The CS121 with ICMP Check

From the firmware version 4.26.x the CS121 is able to answer and send ICMP polls, to check the quality of the network and, in need, can reboot itself.

Figure 19: HTTP - Network & Security ICMP Check

You can enter up to 3 addresses, which will be checked via ICMP. If all 3 addresses are not be reachable, the CS121 will reboot itself after 750 seconds (default). We recommend to use the IP address of a gateway and 2 more addresses, which are reachable steady. If you enter only 1 or 2 addresses, the amount of the checkable addresses is reduced and the possibility to initiate a reboot will increase unnecessarily, because less addresses are at hand for the check of the network quality. If the CS121 will reboot itself often at enabled ICMP check, an analysis of the network is required (e. g. Wireshark), to be able to find the reason. If this should not be possible, you should disable all ports at your switch, which are not required for the CS121, to avoid unnecessarily network traffic. Please take a look into chapter Appendix D., D.9 for further information.



Note: The CS121 supports 3 functions of ICMP via RFC 792:

- 0 – Echo reply
- 3 – Destination unreachable
- 8 – Echorequest

4.2.6 Function hide of HTTP links

The CS121 firmware version 4.23 or higher provides the function to disable the following HTTP links into the “Network & Security” menu:

The screenshot shows the 'Network & Security Settings' page. On the right side, under the 'Enable HTTP Tooltips' section, three options are listed with checkboxes:

- Hide HTTP Device Status Link:
- Hide HTTP Device Status Graphic Link:
- Hide HTTP Device Functions Link:

Figure 20: HTTP – Network & Security Hide HTTP Links

4.2.7 Configuration Static ARP Entries

The CS121 firmware version 4.x or higher provides the configuration of static ARP entries into the “Network & Security” menu:

ARP Settings		
	IP Address	MAC Address
01	192.168.200.17	00:11:85:17:E9:B5
02	192.168.200.18	00:11:85:17:E9:B6
03	192.168.200.19	00:11:85:17:E9:B7
04		
05		
06		
07		
08		
09		
10		
11		
12		
13		
14		
15		
16		

Figure 21: HTTP – Network & Security ARP Settings

You can determine into the ARP Settings, which IP address to which MAC address will be assigned. Therefore the ARP entry will not expire for this IP address. The ARP table will be determined firmly and will never expire! Case of application: HP Teaming or an ARP entry is desired, but the ARP table cannot be restored automatically.

4.2.8 Email

If you wish to define actions to send Emails depending on specified events you need to configure the Email settings.

Figure 22: HTTP - Email Settings

In this menu the internet name of your SMTP mail client is required. If DNS is not configured, the actual mail server name's IP address has to be entered. Please also note that the sender account name (e.g. ups@mailserver.de) should not be a random name, since some mail servers do not allow this. We recommend to use an existing account e. g. ups@mailserver.de. Most servers require matching account names and mail server names. E. g. someone@somewhere.com would be correct, whereas just "someone" would not be sufficient. If the server name and account name do not match, the following error message will be displayed in the CS121 alarm logfile (after some minutes): "Mail: bad answer from mail server: 501 UPSIP204@wrong server.com sender domain must exist."

The user can check the logfile if the email transfer works. The logfile (text.log under the CS121 root directory ../Flash/text.log) can be viewed using FTP, via the UPSMON tool or via the web-browser "Alarm log".

The **firmware version 4.xx** provides the function „Attach AlarmLog to Email“. Enable it and every email, that will be sent from the CS121, will contain the AlarmLog. If you enable the function „Attach all DataLogsog files to email“, every email will contain the AlarmLog, UPSData.log and ExternalDeviceLog. Additionally the email contains the parameters *MAC-Address, UPS Model, UPS Location, IP-Address of the CS121, System Time and Actual Event*.

The **firmware version 4.30.x** provides the function Email database interface format. This option will send Emails configured into the Events/Alarms configuration in a standard, machine readable format. This allows the monitoring and interpretation of alarms by the email software.

You can select the following options for the email logging:

- Never
- Always
- Erors, only

Mailservers outside the LAN require a username and password. For this function please use "email authentication" and enter a username and the corresponding email password (twice). Note: Do not use email authorization if this is not required by your mailserver !

If authorization is required, the email function "AUTH LOGIN" (the CS121 adapter supports only this function) needs to be supported (e. g. freemail.de). This changes the protocol from SMTP to ESMTP and a password is required.

The length of the password should be a minimum 3 and a maximum of 63 characters.

► Send a test-mail to validate your settings after you have applied the mail-settings. A short message on the menu indicates whether the test-mail could be sent or not.

The usage of the settings in the live operation requires the reboot of the CS121 via the "Save, Exit & Reboot" function!



Note: Please ensure that you have specified a DNS-server in menu “Network & Security” if the mail-server could not be reached. You can transfer up to 511 signs.

4.2.9 Email Trap

The Email Trap function provides the transfer of device/UPS data via POP protocol to the UNMS II. Into the UNMS II AdminConsole can the connection type be defined, like the other (UPSTCP, SNMP, RAS), but it is only into the UNMS II module extension „Data Center / TeleService available

Unlike to the other connection types, this one can assimilate incoming email traffic only and is therefore the optimal fitting for relevant to security customers and remote monitoring.

- **Transfer protocol:** POP
- **Reference data:** IDP, VDP, proprietary data
- **Data format:** JSON (as attachment)
- **Mail server configuration:** globally for all connections, into the UNMS II AdminConsole
- **Mail client configuration:** per device as connection type, into the UNMS II AdminConsole
- **One mailbox/user** for all devices, IP- and MAC address distinct

The screenshot shows the 'EMail Settings' configuration window. The 'UNMS Email-Trap Settings' section is highlighted with a red box. The configuration includes the following fields and values:

Field	Value
Mail Server	192.168.200.1
SMTP Port	25
Use TLS Encryption	if available
Sender Account Name	someone@somewhere.com
Send EMail to CS121 Admin...	<input checked="" type="checkbox"/>
CS121 Admin Account	someone@somewhere.com
Email Subject	UPS1
Attach AlarmLog to EMail	<input checked="" type="checkbox"/>
Attach all DataLogs to EMail	<input checked="" type="checkbox"/>
EMail database interface format	<input checked="" type="checkbox"/>
Use EMail Authentication	<input checked="" type="checkbox"/>
Login Name	someone
EMail Password	
Confirm Password	

Figure 23: CS121 Email Settings

If Email-Trap is arranged and the UNMS II got the TeleService module extension, every device can be monitored via emails. The UNMS II displays every device in an own graphical screen with all measuring values and timestamp of the latest update. If a status will change, the values will be updated immediately. If no status changes, the measuring values will be updated into the defined period of time for the „Heartbeat“.

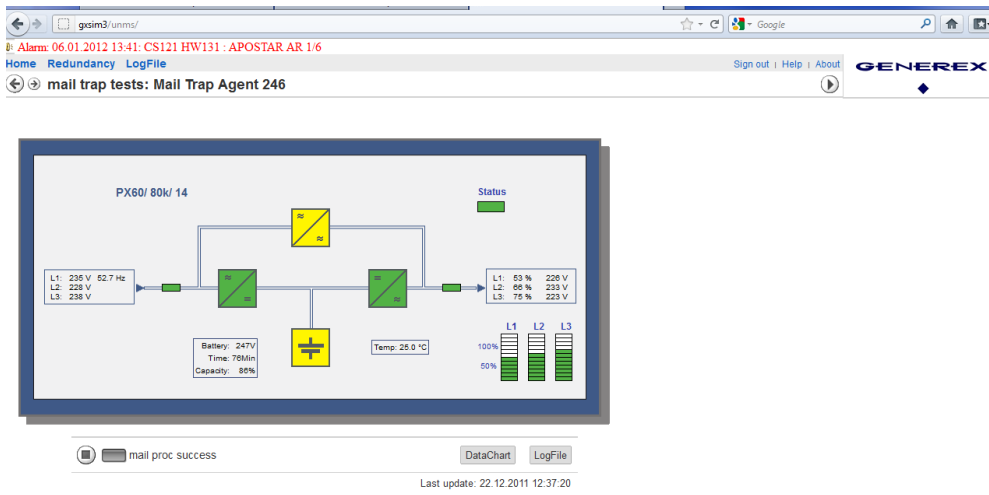

Figure 24: UNMS II screen with timestamp of the latest measuring values update

4.2.10 Email Trap Configuration

The feature will be enabled through an entry into the Email Trap configuration. If you delete the entries, the feature will be disabled.

You can use the „**Import Settings**“ feature to import your email settings from the previous page easily.



Advice: The Email Trap configuration is in accordance with the common email text configuration from the previous page, but **we recommend to create an own email account for the UNMS II Email Traps, because this emails are non-readable for the user and the email account will be stressed unnecessary. This Email Trap account should be used from the UNMS II with TeleService only.** You should change the parameter after using the import settings feature accordingly.

The „Heartbeat“ via email is an additional feature for the UNMS II with TeleService. A new „Heartbeat Timeout“ is at present, in the case, the „Heartbeat Email“ was not received. Thereby a disconnect of the CS121/BACS connection will be monitored. If the „Heartbeat Email“ was not received for 12 hours, an alarm will be triggered.

You can define the interval for the „Heartbeat“ at the CS121 and we recommend to use an interval of 12 hours. Since CS121 firmware version 5.16.x you can define an interval for the Heartbeat in case of an alarm.

UNMS Email-Trap Settings			
Mail Server:	192.168.200.1	Use EMail Authentication:	<input checked="" type="checkbox"/>
SMTP Port:	25	Login Name:	someone
Use TLS Encryption:	if available	E-Mail Password:	
Sender Account Name:	someone@somewhere.com	Confirm Password:	
Receiver:	someone@somewhere.com		
Email Subject:	E-Mail Trap Tests 196		
Send Heartbeat:	<input checked="" type="checkbox"/>		
Heartbeat Period:	3 Hours		
Period In Case of Alarm:	4 Minutes		
		<input type="button" value="Import Settings"/> <input type="button" value="Clear Settings"/> <input type="button" value="Test"/> <input type="button" value="Apply"/>	

Figure 25: UNMS Email Trap Settings

You can trigger an Email Trap via « Test » button. The CS121 AlarmLog will log the sending and the UNMS II with TeleService should display new measuring values within 2 to 3 minutes.

The default selection of the Email Trap events shows, which events are critical and should be sent. If you want to send further events, you can enable them here by clicking the « Apply » button. Please note, that it is required to execute the « Save, Exit & Reboot » function, after you have finished your configuration.

4.2.11 Timeserver

The CS121 uses a timeserver to supply the correct date and time of any event in its local logfile. If no Timeserver is set, the CS121 will not use date and time in the logfile, but a date stamp of 1970.

Timeserver Settings
SNTP or RFC868 TCP compatible timeserver listening on port 37 required.
To disable the timeserver feature set timeserver address 1 to 0.0.0.0.

An exemplary public timeserver can be found here (could be used for both protocols):
129.6.15.29: National Institute of Standards and Technology
or try using a Windows computer in the local network.

Current system time: Thu Jan 6 17:37:50 2011

Timeserver Address 1: 129.6.15.29 SNTP Test

Timeserver Address 2: 0.0.0.0 SNTP Test

Timeserver Address 3: 0.0.0.0 SNTP Test

Connection Retries: 2

Timezone: (GMT+01:00) Amsterdam, Berlin, Bern, Rome, Stockholm, Vienna

Automatically adjust clock for daylight saving changes: (implemented for european timezones only)

Synchronize Time: on incoming RAS connection
 on outgoing RAS connection

Synchronize CS121 With Timeserver

Apply

Set System Time Manually

Timezone: (GMT+01:00) Amsterdam, Berlin, Bern, Rome, Stockholm, Vienna

Date&Time: Date: 6 Jan 2011
Time: 17 37 50

Set System Time

Figure 26: HTTP - Timeserver Settings

The timeserver is important to synchronize the UPS logfile to the actual time. The adapter supports up to three different timeserver IP-addresses. Both, RFC868- and SNTP- protocols are available. Enter the IP-address of any timeserver in your LAN or in the internet. In the internet you will find many timeservers supporting RFC 868 TCP requests, e.g. the IP-address of the timeserver of the National Institute of Standards and Technology is 129.6.15.29; the timeserver of the Physikalisch-Technische Bundesanstalt is 192.53.103.103.



Note: The timeserver will synchronize immediately following the reboot. If the synchronisation fails, the CS121 will attempt another timeserver synchronisation. Following that, the CS121 will attempt a synchronisation with the timeserver every 24 hours. It is required to unlock UDP port 123. From Firmware 4.17 the timeserver will synchronize in a 10 minute interval for at most 24 hours, after it the synchronization interval will be reduced to 24 hours.

The CS121 firmware version 4.28.x provides the option to set the system time manually. Please note, that after the next reboot the synchronization will be lost.

Attention: The NEWAVE UPS got a special feature: Time synchronization via MODBUS command 99. With this signal, the internal clock of the CS121 will be reset to 01:00 every night, because of the optimization of a correct time. To avoid that the CS121 internet

synchronization process will correct this time again (regularly process at every restart and every 24 hours), it is required to disable the SNTP timeserver into the CS121.

Every Windows computer offers the by “Windows Time” a timeserver which synchronizes the time of the PC with an internet clock. How to setup the MS-Timeservice is described below.

If you do not have any internet access in your network, you may setup a timeserver which use the PC clock. For this you may choose any freeware from the internet or download from here: <http://www.generex.de/wwwfiles/timeserver/atcs22.zip>

- Test Timeserver connection: This option is testing the Timeserver connection with a time and date stamp. Please note that the connection to the timeserver only works, when the adapter is not in the configuration mode (IP 10.10.10.10).



Note: Please take a look into the **FAQ** of this user manual for further information how to use a workstation as timeserver.

4.2.12 Language

The CS121 firmware version 5.x or higher is supporting the following languages :

- English
- German
- Chinese
- French
- Spanish
- Polish
- Portugese

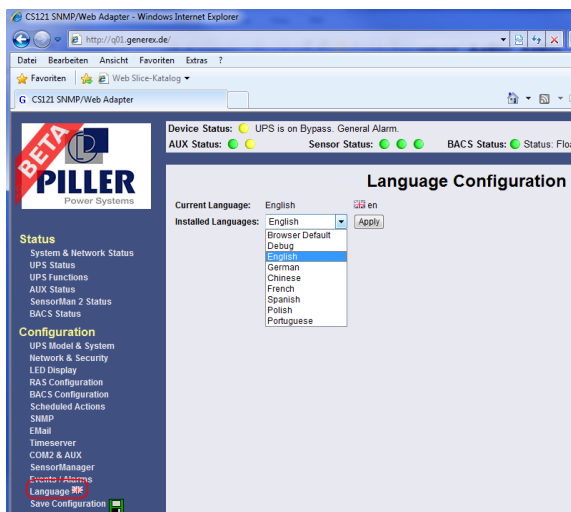

Figure 27: Language Configuration

To be able to use this feature, it might be required, to configure the following into your web-browser (example Internet Explorer 8) :

- Open the Tools/Internetoptions menu into the IE8
- Click the « Language » button

- Add the languages you use to read websites, listing in order of preference



Figure 28: IE8 Internet Options – Languages

4.2.13 Events / Alarms

The Event/Alarm-pages are the main feature of the CS121-configuration and are based on a combination of events and actions (resp. Jobs). At CS121 there are various events defined, such as e.g. “Powerfail”, “UPS Battery bad”, “Battery low” etc. Each event the CS121 allows you to release one or more actions. An action can be e. g. write a log file entry in the alarm log (as default all events do perform a log file event), to send an email or to perform an RCCMD Command (e. g. shutdown signals to several RCCMD clients). For a short introduction into the handling of events and actions see also the section “Quickstart”.

In this menu the relationships between system events such as alarms and the actions to be taken those events are defined.

- To configure your events and actions open the menu “Events / Alarms”. The menu “Event Configuration” displays an overview about the events and the number of configured actions.

Event Configuration										
Event Overview										
Event	Log	Email	RCCMD Shutdown	RCCMD Message	RCCMD Execute	UPS Shutdown	AUX	Dialer	RCCMD Trap	
1 Powerfail	0	0	1	1	1	0	0	0	1	
2 Powerfail	4 Jobs									
3 System s	1. RCCMD Msg 192.168.202.147									
4 UPSMAN	2. RCCMD SD 192.168.202.147									
5 UPS con	3. RCCMD Exe 192.168.202.147									
	4. RCCMD Trap Powerfail on #SERVER UPS can power system for #AUTONOMTIME min.									

Figure 29: HTTP - Event Configuration with tool tip

- Select the desired event and configure it into the event editor.

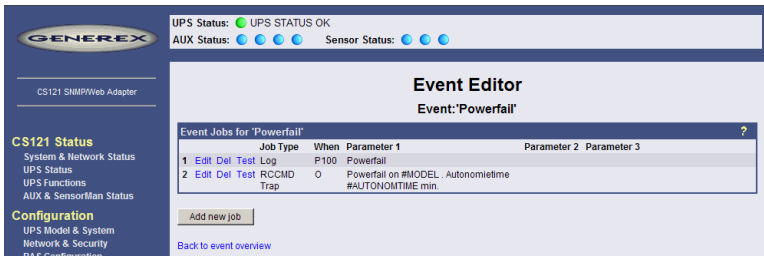

Figure 30: HTTP - Event Editor

The Event Editor allows you to edit, delete and test existing events, as well as to add a new event job. Please click on the desired action to enter the Job Editor, who lets you make the configuration.

Here in the following a short example how to configure an RCCMD shutdown signal.

- Generally, the event “Powerfail” (in same environments also named “Backup mode”) should be used to enter the RCCMD shutdown commands, where required with a delay (“do after”) or depending on the remaining time.

Event Jobs for 'Powerfail'						
	Job Type	When	Parameter 1	Parameter 2	Parameter 3	
1	Edit Del Test Log	P100	Powerfail			
2	Edit Del Test RCCMD Msg	O	192.168.202.51	6003		Attention: Powerfail occured!!!
3	Edit Del Test RCCMD SD	P12	192.168.123.123	6003		

Figure 31: HTTP – Event Editor, Example of a Shutdown-Configuration

- Additionally, all Actions of the Event “Powerfail” should also be entered in the Event “Battery low” without any delay.
- The Event Editor offers you 3 commands on each job: Edit, Delete and Test (see figure above). Please note: The Test will perform the execution actually, which means for example, that testing a RCCMD shutdown job will actually trigger the shutdown signal at the client side! You should perform a shutdown test not until you have switched off the shutdown procedure at the client (RCCMD Configuration, Button Configure shutdown).
- All jobs are not saved until you executed the Save, Exit and Reboot function, not until the device is restarted and running in normal mode (DIP-Switch 1 is ON).
- The number of jobs per event ist limited. CS121 Series 2001-2006 allow up to 25 jobs, running under Firmware 3.5x even up to 35 jobs (approx., depends on the jobs). If more jobs should be executed, you have to configure RCCMD as relay station, as described in section 6.1.1.

4.2.13.1 Threshold Events

Some UPS models allow you to configure thresholds for releasing UPS specific threshold events individually. The CS121 also supports these features, if the UPS includes this option. In this case, you see at the main event menu “Event configuration” at the bottom an additional link “Configure threshold events”. Click here to add a new individual threshold event and you enter the configuration page “Threshold Events”, within you get the possibilities to configure individual events.

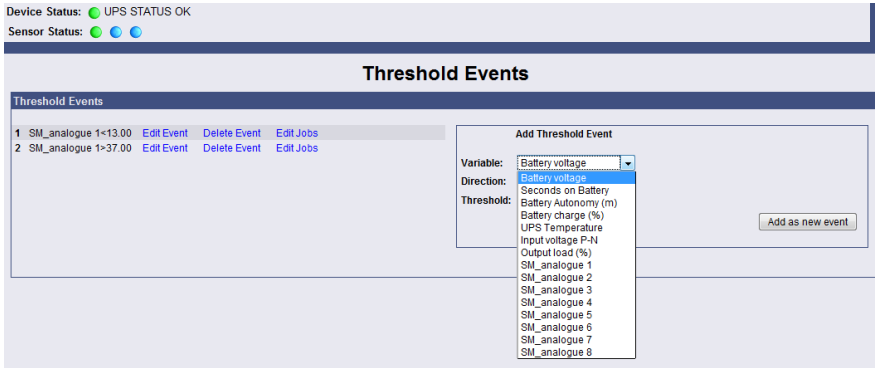

Figure 32: HTTP – Threshold event

The CS121 firmware version 4.27.x or higher provides the option to configure pre-threshold events for the analog sensor inputs (temperature, humidity etc.) additionally. In this example a pre-threshold alarm for a SM_T_COM temperature sensor for the value temperature low of 13°C and temperature high of 37°C were defined. The analog values for external sensors are configurable through the variable SM_analogue 1-8. The proper threshold events for temperature low of 10°C and temperature high of 40°C were defined into the menu “COM2 & AUX” for the SM_T_COM.

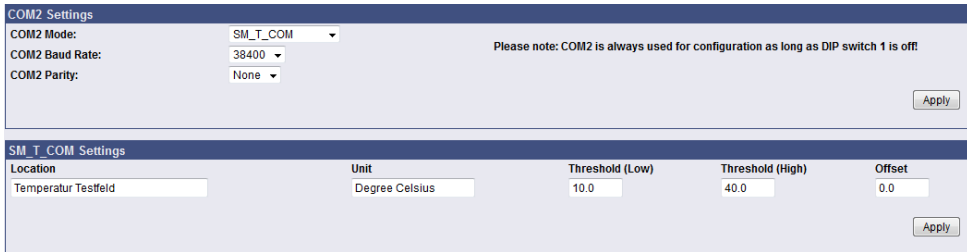

Figure 33: HTTP – COM2 Threshold events SM_T_COM

4.2.13.2 Logfile Entries

For a numerous of events logfile entries are already pre-configured as default. To configure a new logfile entry, type in the field “Text” the desired message you wish to enter in the logfile and choose the option on the right side, when/how often the message should appear in the logfile.

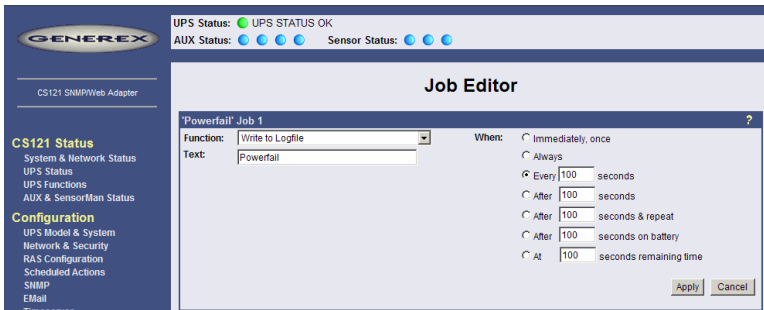

Figure 34: HTTP - Job Editor: Logfile entry

Example above: The text "Powerfail" will be written into the logfile every 100 seconds for as long as the event is present. Other actions on events such as Email, RCCMD shutdown, UPS-Dialer, TempMan etc. can be configured in the same way. Each event may have an unlimited number of actions (executed now, delayed etc.).

4.2.13.3 Email-Job

Figure 35: HTTP - Job Editor: Email-Job

To configure an Email-job follow the entries in the figure above.



Note: Please assure that your Email settings in the menu "Email" are valid.

Beside text entries (up to 511 signs), variables can also be integrated into the email from the CS121. This may personalize your emails. A list of available variables are documented in the appendix. Please note, that the variables are only getting filled, if the event actually occurs, not by testing the action (so a simulation is not possible, you have to create a real alarm to see the full message).

For example please see the figure above: There, the variables #MODEL and #AUTONOMTIME will be substituted with their current values, when the action will be released.

Please notice the syntax, that each variable name must be started with the character # and must be ended with a <space> character.

► Apply your settings and test the Email-job in the "Event Editor" to ensure Email will be sent.

• Continuous, periodic events:

To define an event job, which will be executed continuous, e. g. daily, create a job for the event „UPSMAN started“ like in the following figure:

Figure 36: HTTP - Job Editor: Continuous event job

4.2.13.4 Email-To-SMS

In order to send a SMS message in case of an alarm, you have to use the "Email to SMS Service" of your GSM provider. This is a service where the UPSMAN sends an email to the service center of your GSM provider, who converts the email into an SMS. This service is standard in most GSM networks and very reliable compared to modern solutions. For receiving

emails as SMS you have to contact your GSM provider to open this service. In the following we describe how this works with some GSM providers in Europe, since these providers change this very often, please refer to the website of your GSM provider to find out how "Email to SMS" can be activated for your cell phone.

Example:

GSM Provider T-Systems D1

Your D1 email address will be D1Nr.@t-d1-SMS.de (e.g.:01711234567@t-d1-sms.de) Please note that you enable receiving emails on your cell phone. This is done by sending a SMS with the message "OPEN", to the number 8000.

Only the subject or the text field of the email will be transferred as a SMS, 160 characters from the subject and text field.

Important: If you want to stop receiving emails, please send a SMS to the number 8000, with the text "CLOSE".

(If you want to enable the email transfer again, just send a message to the number 8000, containing the text "OPEN", as described before.)

GSM Provider Vodafone

In germany the vodafone email-to-SMS server is called „vodafone-sms.de“. Please take a look onto the vodafone website of your country for the accordant server name.

Please note that you enable receiving emails on your cell phone. This is done by sending a SMS with the message "OPEN", to the number 3400.

Only the subject or the text field of the email will be transferred as a SMS, 160 characters from the subject and text field.

Important: If you want to stop receiving emails, please send a SMS to the number 3400, with the text "CLOSE".

(If you want to enable the email transfer again, just send a message to the number 3400, containing the text "OPEN", as described before.)

Other providers

Please ask your cell phone network provider for informations about the email to SMS settings.

4.2.13.5 AUX-Port

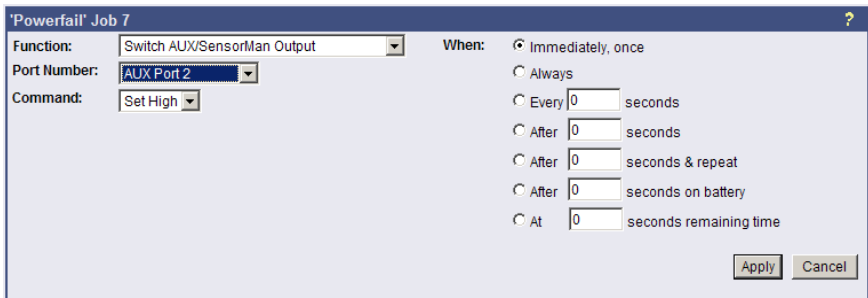

Figure 37: HTTP - Job Editor: Switch AUX-Port

In general, the AUX port is used for auxiliary contacts that can be configured to function as either an Input or an Output (e. g. as input for air-conditioning alarm contacts and as output to switch on electrical sockets or start beepers etc.). When these contacts are set as inputs, they are to be treated as an event in the „Events settings“ menu. Reverse, the AUX contacts to be treated as actions, when they are being used as outputs. The AUX port is also used for connecting an SS4/AUX power outlet manager, in which case all AUX ports function as outputs. For the AUX we provide several "add-ons" like the SS4AUX, SM_IO Relay box, SM_BUZZ alarm beeper, etc. For a complete overview of "add-ons" for the AUX please see the according datasheet, downloadable from www.generex.de. We recommend the usage of our connection terminal CON_AUX for inputs and our CON_R_AUX for incoming and outgoing alarms (outputs).

The CS121 L (external box) allotted from serial number 0121-10417 (delivered from 31.07.2008) about a COM3 port. The CS121 SC (slot card) allotted from serial number 0123-09428 (delivered from 03.09.2008) about a COM3 port too. The AUX port assignment is depending to the hardware type different.

4.2.14 SNMP

Within this menu you can define access controls for SNMP-communities. This concern e.g. SNMP-Management tools, Trap receivers etc... The CS121 firmware version 4.44.x provides SNMP V3. SNMP V3 requires the definition of at least a SNMP V3 user on both sides (CS121, SNMP-Management tool). The following SNMP V3 security level are at present:

- No auth, no priv: No authentication, no privacy, but an SNMP V3 user
- Auth, no priv: Authentication (SNMP V3 user, SNMP V3 password), no privacy
- Auth, priv: Authentication (SNMP V3 user, SNMP V3 password), SNMP privacy password

General SNMP Settings

Enable SNMP Agent: <input checked="" type="checkbox"/>	SNMP v3 Security Level: no auth, no priv
SNMP Version: 3	SNMP v3 User: generex
Use SNMP Authentication Traps: <input checked="" type="checkbox"/>	
Use SNMP Coldboot Traps: <input checked="" type="checkbox"/>	<input type="button" value="Apply"/>

SNMP Communities & Trap Receivers

SNMP Communities			SNMP Trap Receivers	
Address	Community	Permission	Address	Community
1 0.0.0.0		Read only	1 0.0.0.0	
2 0.0.0.0		Read only	2 0.0.0.0	
3 0.0.0.0		Read only	3 0.0.0.0	
4 0.0.0.0		Read only	4 0.0.0.0	
5 0.0.0.0		Read only	5 0.0.0.0	
6 0.0.0.0		Read only	6 0.0.0.0	
7 0.0.0.0		Read only	7 0.0.0.0	
8 0.0.0.0		Read only	8 0.0.0.0	
9 0.0.0.0		Read only	9 0.0.0.0	
10 0.0.0.0		Read only	10 0.0.0.0	

Please note:
Any IP has SNMP access unless you define IP addresses here. This list will be ignored if using SNMP v3.

Test SNMP Traps

You can send a powerfall trap and a power restored trap to the receivers defined below.

Please note: To test newly added receivers, you must save the configuration and reboot the CS121 first.

Figure 38: HTTP – SNMP Settings

The submenu displays a column of 10 manager IP-addresses with the corresponding access permissions, the commands and an example. Use this screen to specify which managers have access to the SNMP adapter agent, the community names (password) and also what type of access the IP managers have - read only or read and write.

Please use the following security algorithms in your SNMP management:

- Auth Algorithm = MD5
- Privacy Algorithm = DES

Figure 39: HTTP – SNMP Algorithms

- **Configuring Trap-receivers**

Use this to determine which IP managers receive traps (messages) from your SNMP-adapter. The screen permits you to send traps about your UPS to IP-addresses (managers).

Also, the menu for switching authentication and cold boot traps are located here. If activated these traps are sent to the configured SNMP trap receivers in the trap receiver list.

- **SNMP Trap Test**

In this menu the user may test the SNMP traps, whereas the defined traps are only used for test purposes and do not represent real traps. The receiver must also be configured in order to make this test work. Additionally, save the settings and reboot your CS121 before testing the communication with the configured IP-address. (does not work in configuration mode). If you use SNMP Test trap, you will receive SNMP Traps of a “Powerfail” and “Power restored” scenario – the simulation of a power outage of some seconds.



Note: If you use SNMP polling to retrieve data from the CS121, you should disable the MODBUS port to avoid interrupts and performance slow down.

4.2.15 COM2 & AUX

4.2.15.1 COM2

This menu takes the user into the submenus for the general settings of the COM2 and AUX connection ports of the CS121-adapter.

COM2 Settings

COM2 Mode: SM_T_COM Configuration

COM2 Baud Rate: Pipe Through 1

COM2 Parity: Pipe Through 2

COM3 Mode: Modbus/SPI3

TempMan

SensorMan

SensorMan 2

RAS

GSM Modem

SiteManager 2

SiteManager 2V3

SiteMonitor 2

SM_T_COM

SM_T_H_COM

Please note: COM2 is always used for configuration as long as DIP switch 1 is off!

Apply

AUX Settings

Port	Name	Message	NC contact	Switch on CS121 Powerup	Powerup Delay (seconds)
1	AUX Port 1	Output	<input type="checkbox"/>	<input type="checkbox"/>	0
2	AUX Port 2	Output	<input type="checkbox"/>	<input type="checkbox"/>	0
3	AUX Port 3	Output	<input type="checkbox"/>	<input type="checkbox"/>	0
4	AUX Port 4	Output	<input type="checkbox"/>	<input type="checkbox"/>	0

Write logfile entry on AUX output:

SS4Mode: Off

Apply

SM_T_COM Settings

Location	Unit	Threshold (Low)	Threshold (High)	Offset
Temperatur Rack	Degree Celsius	10.0	40.0	0.0

Apply

Figure 40: HTTP - COM2 Mode overview

• **Configuration Mode:**

This sets the normal configuration mode for using the CS121 configuration cable (not included).



Note: Unless DIP-switch 1 is OFF the COM2 port is always running in configuration mode.



Note: The Pipe Through Modes are not supported from every UPS model. Please contact GENEREX via support@generex.de, if your UPS model is supporting these modes.

• **Pipe-Through Mode 1:**

Enable or disable the “pipe-through” of the adapter. If enabled, the RS-232 protocol of the UPS will be transmitted to the COM2 of the adapter, so now you can connect any other RS-232 software to the adapter to make use of the RS-232 UPS protocol – parallel to the adapter. This makes the use of multiplexer hardware is no longer necessary. 2 serial interfaces on your UPS which are working parallel are utilized now. Reminder: If you have enabled this function, you can no longer configure the adapter via the serial cable, you must change the settings via HTTP. As communication cable between CS121 and your application you have to use the original CS121 configuration cable (not included).



Note: Please note, that it is required to define the same baud rate of the UPS baud rate in “COM2 Baud Rate”. This is valid for Pipe-Through Mode 1 + 2!

• **Pipe-Through Mode 2:**

Analog to Pipe-through mode 1, the UPS data is piped through to COM2 but not directly. In order to accelerate the internal processes of the adapter, the UPS data is accumulated into memory before being made available to COM2. Consequently, Pipe-through mode 2 also does not provide for the relaying of signals to the UPS through COM2 either. (See also section “Network & Security Settings”)

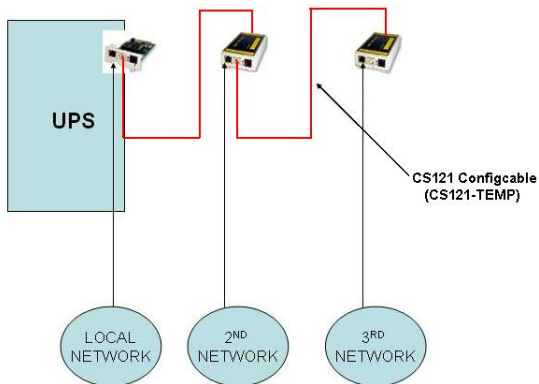

Figure 41: Pipe Thru Installation

- **MODBUS/SPI3**

The selection of MODBUS/SPI3 in the drop down menu of the COM2 settings enables the CS121 MODBUS/SPI3-Profibus function. The default CS121 device types communicating MODBUS via RS232. The special CS121 device types LM and SCM communicating RS485 via the COM2. You can detect by means of the CS121 serial number 0124-..., if you got a CS121 with RS485 interface. The CS121_SPI3 Profibus and LONBUS converters will be connected to the COM2 with RS232 port and as configuration use MODBUS/SPI3. Please take a look into chapter 6.7 for further information.

- **TEMPMAN & SENSORMANAGER I & II:**

The TEMPMAN and SENSORMANAGER are extensions to the CS121 that connect to COM2 of the adapter. The newer of the two products is the SensorManager. These devices are simply plugged into the CS121 for setup and the only mandatory change on the adapter to enable this functioning is to set the COM2 Settings to either TEMPMAN or SENSORMAN. The configuration is easily achieved via the HTML page of the CS121 web server. Please note the drop-down menu and entry fields on the page. (see screenshot above) For in-depth SENSORMANAGER settings see following up chapter.

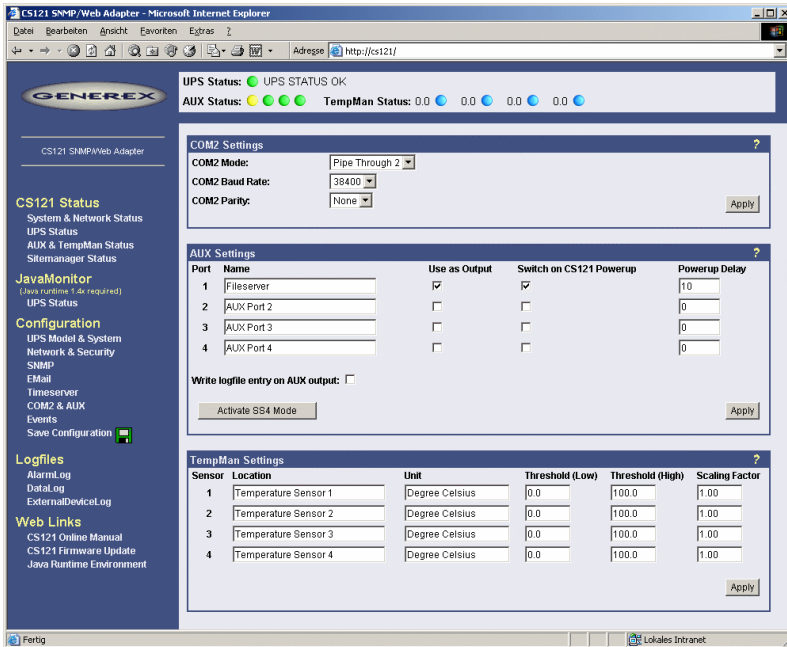

Figure 42: HTTP - COM2 & AUX with TEMPAN

- **RAS-Mode (not supported after 2011)**

The selection of the “RAS”-entry in the drop down menu of the COM2 settings enables the CS121-RASManager function. This function is only operational if a RASMANAGER ist used (CS121 with inbuilt modem) and a RASMANAGER license key is provided (optional, part of RASMANAGER). While it is also possible to select this entry in the Telnet menu, it is only possible to configure the RASMANAGER settings using the HTTP interface of the CS121. See menu “RAS Configuration” for further settings.

- **GSM Modem**

A GSM modem provides the notification or rather forwarding of the UPS events/alarms via SMS. Please take a look into chapter 6.5 for further information.

- **SiteManager 2, SiteManager 2/v3**

The selection of SiteManager 2, SiteManager 2/v3 enables the communication between the CS121 and the SiteManager. The SiteManager is a professional facility management device, which provides 8 configurable analog inputs, 8 digital inputs and 8 switchable relay contacts. Please take a look into the SiteManager II user manual for further information.

- **SiteMonitor 2**

The COM2 selection SiteMonitor 2 enables the communication between the CS121 and the SiteMonitor 2. The SiteMonitor 2 is a professional facility management device, which provides 64 digital inputs for several contact detectors.

- **SM_T_COM**

The SM_T_COM is a temperature sensor for the CS121 and is used for the monitoring and controlling of UPS rooms, server rooms etc.. Please take a look into chapter 6.2 for further information.

• SM_T_H_COM

The SM_T_H_COM is a temperature and humidity sensor for the CS121 and is used for the monitoring and controlling of UPS rooms, server rooms etc.. Please take a look into the SM_T_H_COM datasheet for further information.

4.2.15.2 AUX and SITESWITCH4 Settings

The AUX connection is an input/output port for connecting external contact devices such as alarms or for connecting to an SS4AUX SiteSwitch power socket manager. The SS4 SiteSwitch is a standalone device with a built in CS121. The SiteSwitch SS4 AUX is an inexpensive and practical extension to the CS121 adapters enabling the individual power switching of up to four power sockets – using the inbuilt AUX port (4 pins) of the CS121. By entering the corresponding list number, the AUX ports are switched to output or input.

The AUX port can only read signals, if the port is switched to input. If switched to output the AUX port can send signals to an optocoupler for example. (Refer to the circuit diagrams in the appendix.) After a reboot, the state of the switches remains in the status previous to the reboot.

The following describes the configuration of the AUX ports using the HTML interface. All of the AUX ports 1 – 4 can be manually set to „Output“ so that in the event of an alarm, the CS121 can be preconfigured in the “Events” menu to switch the ports individually. When all ports are set to “Output”, this is equivalent to activating the „SS4 Mode“. The SS4 mode is to be activated when connecting a SITESWITCH4 to the AUX port of the CS121.

When the Output options are deactivated, the AUX ports act as inputs used for monitoring signals such as input from alarm contacts. For example, while configuring port 2 as an input to monitor an alarm, the CS121 can also be preconfigured to respond to the alarm signal from port 2 to shut on or off a device connected to one of the other ports that has been set to Output.

For example see also the settings in figure “HTTP - COM2 & AUX” above.

The OUTPUT setting is to be configured with a power-up sequence so that, for example the fileserver on port 1 will be switched on upon Power up. In the Power up delay-fields the number of seconds after a Power up in which a connected port device is to be switched on can be entered. E.g. the setting 10 in the Power delay column will cause the switching on of the fileserver on Port 1 to be delayed by 10 seconds after the Power up. Note that executing the Save, Exit & Reboot does not cause a Power up, in order to cause a Power up the power supply to the adapter must be interrupted. The differences between a Reboot and a Power up become more noticeable when considering the AUX port contacts. During a Reboot the current status of the ports remain unchanged unless the settings of the ports have been changed from input to output or vice versa. A Power up will set the ports to the preconfigured Power up settings.



Note: From CS121 HW131 it is required, if the AUX ports will be defined from “Unused” to In- or rather Output, that a cable with Pull-Down resistance or a CON-AUX or a CON-R-AUX is connected. Otherwise the status display of the AUX ports is undefined and can be changed by itself anytime !

4.2.16 SENSORMANAGER

The SENSORMANAGER is a data measurement and collecting unit which allows the individual measurement and monitoring of 8 analog measurement devices (0-10V) and 4 digital alarm inputs or 4 outputs (open collectors). SENSORMANAGER has its own chapter in the manual, wherein the features and field of applications etc. pp. are described as well as in depth the various specific configurations.

In generally, the SENSORMANAGER unit is connected with its COM 1 port to CS121's COM 2 port, which has to be configured as SensorManager mode.

Within the configuration page “Sensor Manager Settings” of the CS121 you can - among others - define limit values when events (to be configured in “Events / Alarms”) will be released.

Sensor Manager Settings								?
Sensor	Location	Unit	Current Value	Threshold (Low)	Threshold (High)	Sensor Type	Scaling Divisor	Scaling Offset
1	Temp. Sensor 1	Degree Celsius	0.0	0.0	100.0	Custom	2.55	0
2	Temp. Sensor 2	Degree Celsius	0.0	0.0	100.0	Custom	2.55	0
3	Temp. Sensor 3	Degree Celsius	0.0	0.0	100.0	Custom	2.55	0
4	Temp. Sensor 4	Degree Celsius	0.0	0.0	100.0	Custom	2.55	0
5	Temp. Sensor 5	Degree Celsius	0.0	0.0	100.0	Custom	2.55	0
6	Temp. Sensor 6	Degree Celsius	0.0	0.0	100.0	Custom	2.55	0
7	Temp. Sensor 7	Degree Celsius	0.0	0.0	100.0	Custom	2.55	0
8	Temp. Sensor 8	Degree Celsius	0.0	0.0	100.0	Custom	2.55	0

Apply

Sensor Manager Inputs					?
Input	Location	NC Contact	Input	Location	NC Contact
1	Digital Input 1	<input type="checkbox"/>	3	Digital Input 3	<input type="checkbox"/>
2	Digital Input 2	<input type="checkbox"/>	4	Digital Input 4	<input type="checkbox"/>

Apply

Sensor Manager Outputs						?
Output	Location	NC Contact	Output	Location	NC Contact	
1	Digital Output 1	<input type="checkbox"/>	3	Digital Output 3	<input type="checkbox"/>	
2	Digital Output 2	<input type="checkbox"/>	4	Digital Output 4	<input type="checkbox"/>	

Apply

Figure 43: HTTP – Sensor Manager Settings

Please see SensorMan in section “Accessories” of this manual.

4.2.17 RAS Configuration

This is the standard setting for the RASManager, the CS121 with the built-in modem. Most of the CS121 products can also have the RASManager feature enabled by purchasing PPP License Key and by connecting a supported modem. The RASManager, RASControl Software, the UNMS II Software with the TeleService Module come with an extra user manual for describing this feature.

RAS Manager Settings				?
Common Settings				
Modem:	RAS Manager analog	Modem First Time Init:	AT&F&D0E0X3S30=24S12=10S0=0&w0	
RAS Manager Phone Number:		Modem Init String:	AT	
RAS Client Settings				
Act as Client:	<input checked="" type="checkbox"/>	Username:	user	
PPP Operation Timeout (sec):	300	Password:		
Number to Dial:		Confirm Password:		
Number of Connection Attempts:	5	Inactivity Timeout (sec):	60	
Destination Address:	0.0.0.0			
RAS Server Settings				
Act as Server:	<input checked="" type="checkbox"/>	Username:	user	
Enable Callback:	<input type="checkbox"/>	Password:		
Server IP Address:	192.168.55.1	Confirm password:		

Apply

Figure 44: HTTP - RAS Manager Settings

4.2.18 Scheduled Actions



Figure 45: HTTP – Scheduled Actions

In the “Scheduled Actions” menu you can schedule the following actions:

Self test: A self test is a short hardware test, which switches the device to a short discharging.

Battery test: A battery test is a short battery test, which switches the battery to a short discharging.

Custom test: A custom test checks, if the batteries are able to hold the downtime at least.

Full test: A full test is used to calibrate the UPS and will discharge the batteries till the „battery low“ limit. This test should be done once a year at most, because to avoid a damage of the batteries.

Online (inverter mode): This is a function to switch into “Normal Mode” (power supply of the battery). This status is the normal UPS mode and it is actual not necessary to schedule any kind of commands.

Offline (bypass mode): This is a function to switch into “Bypass Mode”. Thereby the inverter of the UPS is not in usage and the current would not be buffered, if a failure would occur. This mode displays a failure of the UPS, **please call the UPS service to solve the problem.**

Shutdown UPS: This action causes the switch off of the UPS. This could be arranged, if a low charging of the battery occurs, in case of a fire alarm or a power failure happens.

Switch UPS Outlet: This is a function to switch of the UPS outlets (not provided of every UPS).

Switch AUX port: In general the AUX port is used for additional contacts, which can be configured as in- or output (e. g.: as input for alarm contacts of an air conditioner or as an output to switch a connector). If the contacts will be configured as inputs, they are able to be used as event in the “Event Settings”. Additionally you can establish jobs, if they are configured as outputs. The menu “Switch AUX port” is for outputs only. You cannot switch inputs!

RCCMD Shutdown: Here, IP-addresses from computers with RCCMD connection (receivers) in the network can be entered. The CS121-adapter can then initiate a multi-server shutdown. The timing for such a shutdown procedure depends on the configured down time of the adapter (default: time of the remaining capacity of battery in min., during a long power fail.) or on a countdown timer. Extended CS121-adapters can also use more events (e.g. battery low, battery defect, communication lost etc.) as RCCMD signals. Please contact your UPS dealer for more information.

RCCMD Message: With this job the user can combine and configure a text message with RCCMD event. Text messages can be sent to RCCMD receivers. This makes it possible to send text messages via RCCMD (version 2 or higher) to a Windows 2000 server or a Unix computer, using the “NET SEND” or the respective “WALL” method. The problem with notifying network users on different operating systems is therefore solved.

RCCMD Command: This RCCMD signal will cause any RCCMD receiver (e.g. another CS121, RCCMD client or SITEMANAGER, SITESWITCH4) to execute a command or program, e. g.: to start a program at a remote work station.

Native UPS Command: (for very experienced users only) This is a function to execute UPS own commands. Assumption: The user knows the "Command IDs" and the proper parameter. These commands require additional parameter. If you want to use these kind of commands, just contact your UPS dealer.

(De-) Activate Event: This is a function to switch off appointed events/alarms.

Send WOL: WOL stands for "Wake on LAN". This function uses data packages to prompt other computers in a local network to start-up. Please use this function in the event "UPSMAN started" to wake up computers which have been shut down previously after an extended power outage, which cause the CS121 or UPS to switch off completely. Additionally you may add this WOL signal to the EVENT "Power restored". Advice: Not every network card is providing this function or is password protected. Activate this function into the BIOS settings of the motherboard.

Send Periodic Email: This is a function to send the log files via email periodically (from firmware 4.xx and higher).

4.2.19 Save Configuration / Reboot

If you are satisfied with your configuration select "Save, Exit & Reboot" and wait until the adapter informs you about the reboot-process. Do NOT close your web-browser!

4.3 Reading the Logfiles

The CS121-Alarmlog contains the alarm protocol of events that were designated as alarms in the Event/Settings-section and include the user defined alarm settings of the CS121 configuration as well as the events that are designated as alarms in the UPS native protocol. These entries include such things as CS121 Admin defined email notifications which lead to a much higher alarm entry log level than would otherwise be the case if only UPS protocol defined alarms were being recorded. For explanation, the following illustrates typical log file entries made by the UPS:

The CS121 logs the time after a new start up:

```
01/17/2007,16:21:45, Synchronized with timeserver 192.53.103.103. OK
```

This indicates a successful synchronization with the timeserver.

```
01/17/2007,16:23:39, UPSMAN <UPS model> has started
```

UPS communication functions and device is in normal operation mode. This is the standard entry after every successful reboot of a CS121.

(The following entries result only from user defined settings as with the CS121 ADMINISTRATOR EMAIL Settings.)

```
01/17/2007,16:28:39, MAIL: subject "CS121 Event 4" successfully sent.
```

All "EVENT X" designated alarms are viewable in the EVENT list of the web browser. EVENT 4 for this particular UPS is the EVENT "UPSMAN started" – This means that an Email was sent with the text "UPSMAN started" which acts to confirm the log entry of 08:06:50 as Email.

```
01/17/2007,16:28:47, MAIL: subject "CS121 Event 16" successfully sent
```

In this case, the Scheduler has been activated and is ready for operations. In this case, the scheduler is set to conduct a "Selftest" which it in turn relays per email to the designated CS121 ADMIN.

```
01/17/2007,16:28:47,MAIL: subject "CS121 Event 26" successfully sent
```

```
01/17/2007,16:29:03,MAIL: subject "CS121 Event 27" successfully sent
```

01/17/2007,16:29:28,MAIL: subject "CS121 Event 28" successfully sent
01/17/2007,16:30:46,MAIL: subject "CS121 Event 29" successfully sent

These are 4 Emails indicating the status of the AUX Ports (Auxiliary connection for external alarms), which are set to give notification of the status signal LOW. Since the AUX Status can only be set to High or Low and given that the CS121 in itself cannot distinguish the device, an alarm email will be sent by the CS121 to the designated ADMIN at startup per default with the startup status of each connected alarm. In this case, it is up to the administrator to determine if the emails indicate an actual alarm or not.

01/17/2007,16:34:48,MAIL: subject "CS121 Event 38" successfully sent
01/17/2007,16:35:12,MAIL: subject "CS121 Event 39" successfully sent
01/17/2007,16:35:16,MAIL: subject "CS121 Event 40" successfully sent
01/17/2007,16:35:28,MAIL: subject "CS121 Event 41" successfully sent
01/17/2007,16:35:33,MAIL: subject "CS121 Event 42" successfully sent
01/17/2007,16:35:40,MAIL: subject "CS121 Event 43" successfully sent
01/17/2007,16:35:51,MAIL: subject "CS121 Event 44" successfully sent
01/17/2007,16:35:57,MAIL: subject "CS121 Event 45" successfully sent

These are 8 Emails sending information about analogue sensors (temperature, humidity and the like) that are connected to a SENSORMANAGER, indicating that all controlled values are within tolerance levels - or that no sensor is connected to the device or connection port.

01/17/2007,16:36:30,MAIL: subject "CS121 Event 54" successfully sent
01/17/2007,16:36:41,MAIL: subject "CS121 Event 55" successfully sent
01/17/2007,16:36:48,MAIL: subject "CS121 Event 56" successfully sent
01/17/2007,16:36:57,MAIL: subject "CS121 Event 57" successfully sent

These 4 Emails indicate that the digital sensors (for airconditioning, fire alarms and the like) of the SENSORMANAGER, are either in the normal state or that no sensor is connected.

01/17/2007,17:41:12,MAIL: subject "CS121 Event 62" successfully sent
01/17/2007,17:41:36,MAIL: subject "CS121 Event 63" successfully sent
01/17/2007,17:43:23,MAIL: subject "CS121 Event 64" successfully sent
01/17/2007,17:44:01,MAIL: subject "CS121 Event 65" successfully sent

These 4 Emails indicate the status of the digital alarm contacts of the sensors (for Emergency OFF, fire extinguisher and the like) connected with the SENSORMANAGER, showing either the status is NORMAL or that nothing is connected.

01/17/2007,17:52:13,MAIL: subject "CS121 Event 70" successfully sent

This Email shows that no SENSORMANAGER is connected although the CS121 is configured as having a connection to a Sensormanager. This informs the ADMIN that the CS121 is incorrectly configured. In this case, the user should correct the settings.

The UPS data will be logged with timestamp into the CS121 DataLog.

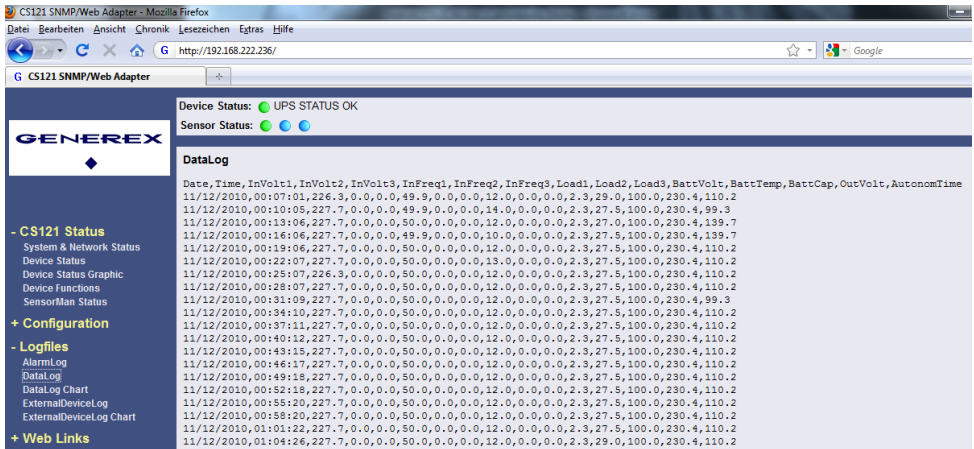

Figure 46: HTTP – CS121 DataLog

The data of the connected devices (e. g. temperature sensor) will be logged into the CS121 ExternalDeviceLog.

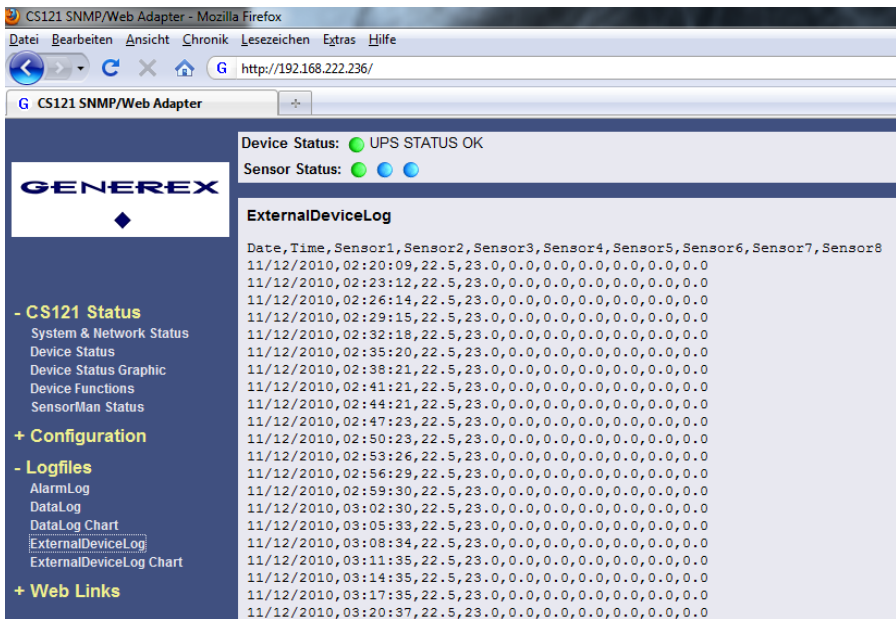

Figure 47: HTTP – CS121 ExternalDeviceLog

In figure 62 the logging of a SM_T_H_COM is displayed, sensor 1 for the temperature, sensor 2 for the humidity.

At unify their events will be imported out of the UPS directly and are displayed into the CS121 menu LogFiles, "UPS Events".

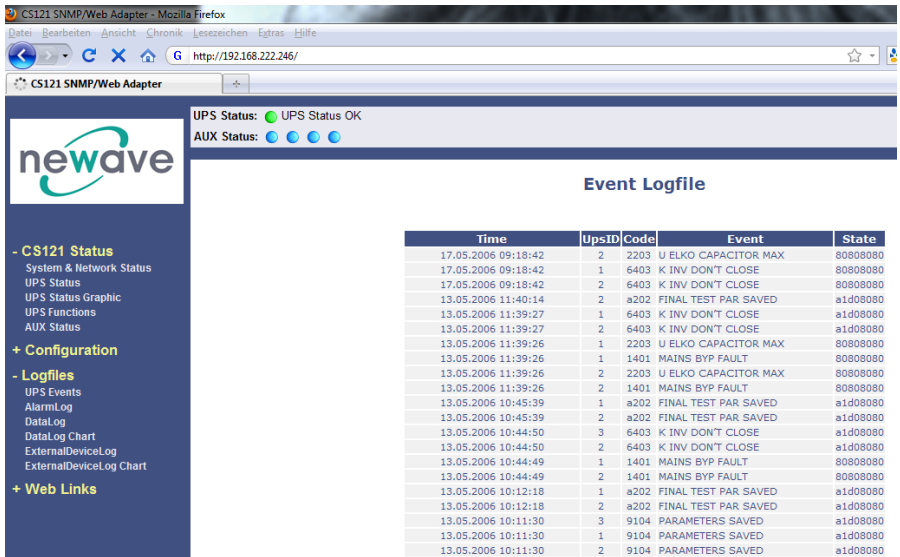

Figure 48: HTTP – CS121 UPS Events

4.4 RCCMD

RCCMD (Remote Console Command) is the world’s most successful shutdown client for heterogeneous networks and is the most secure way to establish a UPS multiple server shutdown sequence today. RCCMD clients are listening to an RCCMD server which is usually an UPSMAN software, CS121 or any third-party UPS manager which has a license to use RCCMD. An RCCMD server is found inside any CS121 and is triggering RCCMD clients in case of alarms. Therefore RCCMD requires such listeners on each client-computer you wish to forward RCCMD signals. For installation of RCCMD at client-side please see the section in chapter “Add-on software”.



Note: RCCMD clients are optional and not freeware. Most CS121 are equipped today with a single RCCMD standard license, some UPS makers add more licenses, other do not deliver any license at all with a CS121. Contact your UPS maker and ask for the license regulations for RCCMD in conjunction with your CS121.

4.4.1 RCCMD Jobs

You can define RCCMD jobs into the CS121 menu “Events/Alarms”.

- Powerfail

This event occurs, if the UPS will lose the power supply. This event might be the optimal fitting for the definition of RCCMD shutdowns.

- System Shutdown

This event will be triggered, if the defined system shutdown time was reached. This event should be used for operations only, which will force a shutdown immediately.



Note: This event is the last event, that the CS121 can execute prior of the UPS shutdown. Do not use this event to execute RCCMD shutdowns, because the remaining time is not assured! We recommend to use the event powerfail for the RCCMD shutdowns.

- Battery low

This event will be triggered from the UPS, if the battery capacity of the UPS has reached a critical state.

- UPSMAN started

This event will be triggered periodical, if the CS121 is in normal operation. You can use this event, if you want to start actions, which should be triggered into normal operation.

4.4.2 RCCMD Traps

RCCMD traps are “push” messages (like SNMP traps), which will be send from the CS121 automatically to the RCCMD client. The RCCMD traps are text messages only.

If you want to define RCCMD Traps by yourself, you can use the following variables :

- #OUTPOWER – Output power in %
- #BATTCAP – Battery capacity in %
- #INVOLT – Input voltage in V
- #TEMPDEG – Temperature in °Celsius
- #AUTONOMTIME – Autonomy time in minutes
- #LASTSTBUPT – Last test battery autonomy time in minutes
- #STATUS – Status
- #ISTEST – In test mode
- #LASTERR – Last error
- #TIMEUNTILSHTDWN – Time until shutdown in minutes
- #RUNTIME – Runtime in minutes
- #INCURR – Input current in A
- #BATTVOLT – Battery voltage in V
- #INFREQ - Input frequency in %
- #OUTFREQ – Output frequency in %
- #CNT_PF – Counter power failures
- #CNT_BL – Counter battery low events
- #CNT_SD – Counter shutdowns
- #CNT_SA – Counter shutdowns active
- #CNT_TF – Counter test failures
- #INPHASES – Amount input phases
- #OUTPHASES – Amount output phases

Example of the configuration of a RCCMD Trap job for the event “Power restored”:

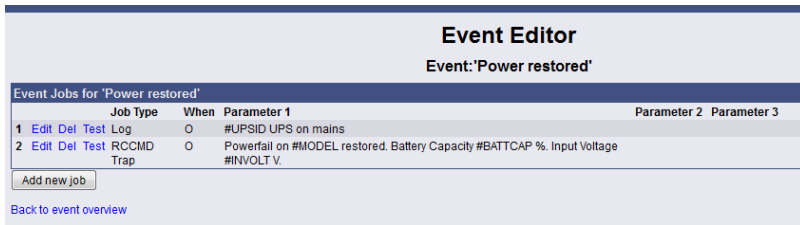

Figure 49: HTTP - Job Editor: RCCMD Trap, Event « Power restored »

You can add any kind of text/measurement units. It is required to add a blank ahead and behind the variable (#MODEL). If you want to receive more variables, please separate them with a blank and a « . ».

Powerfail on #MODEL restored. Battery Capacity #BATTCAP %. Input Voltage #INVOLT V.

The RCCMD Trap would be received like that :

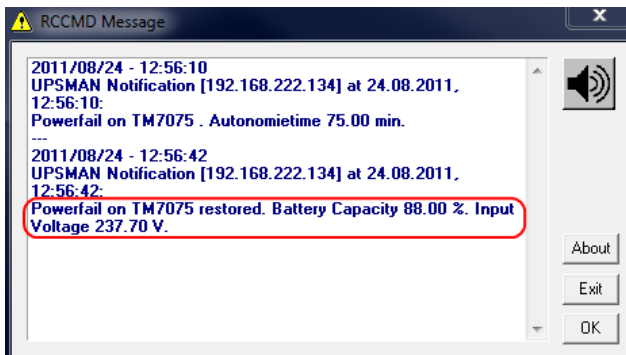

Figure 50: HTTP - Job Editor: RCCMD TRAP

• Because the CS121 adapter plays an active roll when executing its actions “Message”, “Shutdown” and “Command” (that is to say the CS121 -adapter sends an RCCMD-signal to an RCCMD client), it is necessary, to enter the IP-address in parameter 1, and the port number of the RCCMD client in parameter 2 (default port is 6003). Additionally, the RCCMD client must either be pre-configured with absolutely no sender filter or should be pre-configured with the IP-addresses of the particular UPSMAN servers (like UPSMAN, CS121 or other RCCMD compatible sender) that are to function as recognized senders. These configurations take place when installing the RCCMD client service. Further details are in the RCCMD software documentation.

Attention: At the function RCCMD Command it is required to configure a job for every single client. It is not possible to request several clients/IP-addresses in one job to execute a command.

• RCCMD also includes the feature “RCCMD Trap”. RCCMD Trap is a method for sending information to the RCCMD stations which have been applied to the CS121. RCCMD Traps invokes messages at all RCCMD stations. Because of RCCMD plays an active roll in this mode no receiver information is to be entered in the parameters of this job (see also following sections). It is condition to enable the RCCMD Trap control box in the menu “Network & Security Settings”.

• The CS121-adapter uses the parameter-based RCCMD Version 2, which can execute different actions on the same TCP channel. RCCMD Version 1 clients can only execute one action (shutdown file execution as default, so any RCCMD signal which is transmitted »

RCCMD client V1 will cause a shutdown of this server) RCCMD Version 3 is capable to handle also redundant UPS installations (eg. PC with 2 power supplies and 2 UPS).



Note: For all 3 RCCMD event functions a list of the user configured RCCMD receivers appear in every RCCMD event.

- The amount of RCCMD clients is limited and dependent of the size of the RAM. 50 RCCMD clients per CS121 are guaranteed. If you need more than 50 clients to reach, we recommend to use RCCMD relays (see chapter 5.1.4). However it is only possible to execute 50 clients at the same time, meaning that the first 50 RCCMD clients are executed followed by the next 50 etc. We recommend to change the timing parameters of the RCCMD-jobs that always less than 50 commands are transmitted at the same time. We also recommend to use an RCCMD client as Relaystation if you want to shutdown more than 50 computers from a single CS121. (see section 6.1.1 RCCMD with SSL for Windows

The Secure Sockets Layer (SSL) protocol is a cryptographic protocol that provides security and data integrity for communications over TCP/IP networks.

Use your Web-browser to navigate to the address of your UPS Web-Manager. Click the "Network & Security" configuration button and enable the SSL network feature.

MAC Address:	00-03-05-0E-09-E1	Enable Telnet Server:	<input checked="" type="checkbox"/>
Network Card Speed:	AUTO	Enable HTTP Server:	<input checked="" type="checkbox"/>
Local Address:	192.168.202.98	HTTP Port:	80
Gateway Address:	192.168.202.1	HTTP Refresh Time:	10
Subnet Mask:	255.255.255.0	HTTP Default Page:	UPS Status
DNS Server:	192.168.202.8	Enable HTTP Tooltips:	<input checked="" type="checkbox"/>
Change Administrator Password:		Enable UpsMon Server:	<input checked="" type="checkbox"/>
Confirm Password:		Use RCCMD2 Traps:	<input checked="" type="checkbox"/>
Change UpsMon & SS4 Password:		Enable RCCMD Listener:	<input type="checkbox"/>
Confirm Password:		RCCMD Listener Port:	6002
Use UpsMon Password for Web Pages:	<input type="checkbox"/>	RCCMD Timeout:	180
		Use RCCMD SSL:	<input checked="" type="checkbox"/>

Figure 51: RCCMD SSL Settings

The SSL network feature requires correct time settings, so it is required to configure a timeserver. Click the „Timeserver“ configuration button and enter the address of at least one timeserver.

Time Settings

RFC868 TCP compatible timeserver listening on port 37 required.
To disable the timeserver feature set timeserver address 1 to 0.0.0.0.

Some public timeservers (could be used for both protocols):
129.8.15.29 : National Institute of Standards and Technology
192.53.103.103 : Physikalisch- Technische Bundesanstalt

Current system time: Thu Dec 4 23:49:26 2008

Timeserver Address 1: 192.53.103.103 SNTP

Timeserver Address 2: 0.0.0.0 SNTP

Timeserver Address 3: 0.0.0.0 SNTP

Timezone: (GMT+01:00) Amsterdam, Berlin, Bern, Rome, Stockholm, Vienna

Automatically adjust clock for daylight saving changes: (implemented for european timezones only)

Connection Retries: 2

Synchronize Time on incoming RAS connection:

Synchronize Time on outgoing RAS connection:

Test Timeserver 1 Test Timeserver 2 Test Timeserver 3 Synchronize CS121 clock now

Figure 52: Timeserver Settings

Click the „Save Configuration“ button and the „Save, Exit & Reboot“ button to confirm your settings.

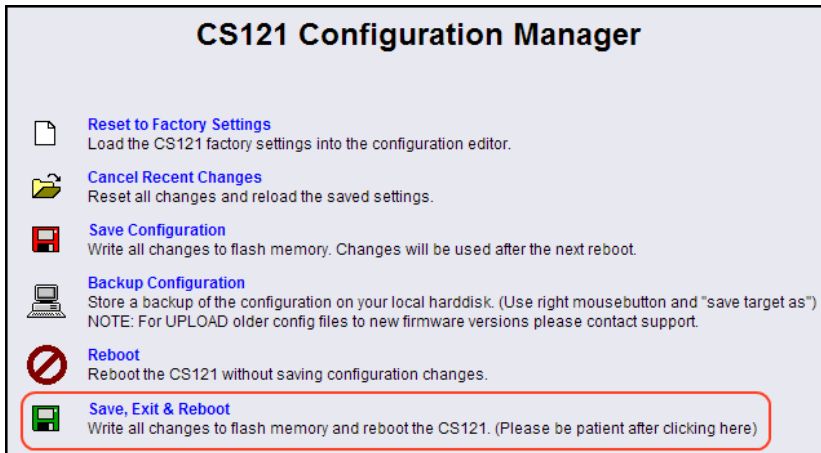

Figure 53: Settings Confirmation

4.4.3 RCCMD with own SSL certificates

In this chapter we will describe, how to use an own SSL certificate with RCCMD, e. g. OpenSSL (<http://www.openssl.org>) :

Be your own CA

Using OpenSSL it is quite simple to become your own CA. Just run:

```
CA.pl -newca
```

Done! Just ensure, that you select a useful CN (common name)!

Create your RCCMD certificate

You need to create your certificate for RCCMD now. As it will use it for verification, it should contain the same useful common name (CN), that you selected for the CA. The private key must not be encrypted to let the RCCMD Client (service) start without trouble. Therefore we use the “-nodes” option and the “-newreq” command:

```
CA.pl -newreq -nodes
```

Sign with your CA:

```
CA.pl -sign
```

Now create an empty file named “rccmd.pem” and copy the cert information of *newcert.pem* (rccmd certificate), *newkey.pem* (private key) and *cacert.pem* (CA) into it. Please note, that the exact copying is required to use it without trouble!

Use your own RCCMD certificate

Do the following steps at the RCCMD Client and every sender (e. g. UPS Web Manager):

- Backup the existing “rccmd.pem”
 - Replace the existing “rccmd.pem” with your own
 - Restart the RCCMD Client
 - Restart the RCCMD Sender
- RCCMD client as relay station)



Note: The RCCMD timeout is 60 seconds, meaning that after this time the communication to the RCCMD client will be stopped and a logfile entry will be made. When an OK response from the client is received, the

system assumes a successful RCCMD Shutdown and proceeds with a shutdown of the next 50 RCCMD clients. Every minute one batch of up to 50 RCCMD clients can be executed without SSL.



Note: All network components, such as routers, hubs etc. need to be fully UPS-supported, as it is otherwise not possible to reach all clients during the network shutdown.

4.4.4 RCCMD Shutdown

The screenshot shows the 'Job Editor' window for a 'Powerfail' job. The 'Function' is set to 'Send RCCMD Shutdown to remote client'. The 'Client IP or Hostname' is '192.168.10.23' and the 'Client Port (Default: 6003)' is '6003'. The 'When:' section has radio buttons for 'Immediately, once', 'Scheduled in 0 seconds', 'Every 0 seconds', 'After 0 seconds', 'After 0 seconds & repeat', 'After 0 seconds on battery', and 'At 0 seconds remaining time'. A note states: 'Actions will only be executed if event condition is still true after the specified seconds!'. 'Apply' and 'Cancel' buttons are at the bottom right.

Figure 54: HTTP - Job Editor: RCCMD Shutdown

Here, IP-addresses from computers with RCCMD connection (receivers) in the network can be entered. The CS121-adapter can then initiate a multi-server shutdown. The timing for such a shut down procedure depends on the configured down time of the adapter (default: time of the remaining capacity of battery in min., during a long power fail.) or on a countdown timer. Extended CS121-adapters can also use more events (e.g. battery low, battery defect, communication lost etc.) as RCCMD signals. Please contact your UPS dealer for more information.

Please note at the configuration of the timer box, that the time specifications outside the timer box (Immediately, once and Scheduled in) will be ALWAYS executed. The time specifications inside the timer box (Every/After seconds, After seconds & repeat, After seconds on battery, At seconds remaining time) will be only executed, if the alarm/event is still present.



Note: For security reasons we recommend to make the same RCCMD shutdown entries for the Event "Battery low" - but in this Event without any delays to avoid that the server crashes because of low battery alarm.

In case a connection is established using telnet or http, the RCCMD-command can be tested without using disrupting power to the UPS. At the Web-browser you simply have to press "test" to transmit the shutdown signal immediately. (see figure HTTP - Event Editor above)

Due to network settings it is possible that this test is answered with "failed". The signal is often sent and received although the receiver may not respond correctly. In such cases, only use the receiver side to check if the signal has actually been received. For checking the communication between RCCMDs you have to check the RCCMD log file on both sides. In the CS121 the logs are inside the Alarm log, at the RCCMD client side the logs are found inside the RCCMD folder e. g. rccmd.log.

Example for the configuration of a RCCMD Shutdown

Click on the CS121 Web-interface in the menu „Configuration“ the *Events/Alarms* button. Select the event *Powerfail*.

Event Configuration						
Event Overview (Events 1-21 of 21)						
	Event	Disabled	Log	Email	RCCMD Shutdown	RCCMD Message
1	Powerfail	<input type="checkbox"/>	1	0	0	0
2	Power restored	<input type="checkbox"/>	1	0	0	0
3	Powerfail (2 Jobs)			0	0	0
4	System Log Powerfail			0	0	0
5	UPS 2. RCCMD Trap Powerfail on #MODEL . Autonomietime #AUTONOMTIME min.			0	0	0
6	UPS connection lost	<input type="checkbox"/>	1	0	0	0
7	UPS connection restored	<input type="checkbox"/>	1	0	0	0

Figure 55: HTTP – Event Configuration

Click the “Add new job” button.

Event Editor						
Event: 'Powerfail'						
Event Jobs for 'Powerfail'						
	Job Type	When	Parameter 1			
1	Edit Del Test Log	P100	Powerfail			
2	Edit Del Test RCCMD Trap	0	Powerfail on #MODEL . Autonomietime #AUTONOMTIME min.			
Add new job						
Back to event overview						

Figure 56: HTTP – Event Editor

Select the function “Send RCCMD Shutdown to remote client” in the Job Editor:

Job Editor	
'Powerfail' Job 3	
Function:	Write to Logfile
Text:	Write to Logfile
	Send an EMail
	Send RCCMD Shutdown to remote client
	Send RCCMD Message to remote client
	Send RCCMD Command to remote client
	Shutdown UPS
	Switch AUX/SensorMani/UPS Output
	Send RCCMD Trap
	Send Wake-On-LAN Magic Packet
When:	<input checked="" type="radio"/> Immediately, once <input type="radio"/> Scheduled in <input type="text" value="0"/> seconds <input type="radio"/> Every <input type="text" value="0"/> seconds <input type="radio"/> After <input type="text" value="0"/> seconds <input type="radio"/> After <input type="text" value="0"/> seconds & repeat <input type="radio"/> After <input type="text" value="0"/> seconds on battery <input type="radio"/> At <input type="text" value="0"/> seconds remaining time

Figure 57: HTTP - Job Editor

Enter the ip-address of the client, that should receive the shutdown.

Description of the scheduler box :

"Immediately, once: Action/Job will be executed in case that this EVENT is true **immediately**, only **once** the Action/Job is started (no repeat)".

"Scheduled in": Action/Job will be executed in case that this EVENT is true with a **scheduled delay** of x seconds. Unregarded if the EVENT is still true or not, after the delay the action will be started.

The timer settings in the blue framed scheduler box will be executed only, if the EVENT is still true after the delays/countdowns have run out.

E.g. if any action has been configured at "do after 10 seconds" than this action will NOT be started, if after 9 seconds the EVENT is no longer true. Only if 10 seconds this EVENT was present, the action will be triggered.

See below the explanation of all timer event configuration options for this type :

"Always": Action/Job will be executed in case that this EVENT is true immediately and **repeated always** as long as the EVENT is true (every 5 seconds according to poll cycle default of a CS121).

"Every x seconds": Action/Job will be executed in case that this EVENT is true with a delay

of x seconds and **repeated** every x seconds again.

"After x seconds": Action/Job will be executed in case that this EVENT is true **after** a delay of x seconds. Action will be cancelled, if EVENT is false before time has run out.

"After x seconds and repeat": Action/Job will be executed in case that this EVENT is true **after** a delay of x seconds and will be **repeated** after x seconds again. Action will be cancelled, if EVENT is false before time has run out.

"After x seconds on battery": Action/Job will be executed in case that the EVENT UPS ON BATTERY or POWERFAIL is true and **after** a delay of x seconds. Action will be cancelled, if EVENT is false before time has run out. This Job is identical to the EVENT POWERFAIL and the configuration "After x seconds".

"At seconds remaining time": Action/Job will be executed in case that the UPS runs on battery/Powerfail and the remaining time, read by the UPS or calculated by the internal CS121 routine has reached a certain remaining time. Only useful if the "Autonomytime" of your UPS can be regarded as reliable.

"REMAINING TIME " is defined as Autonomytime in seconds of this UPS at the actual discharging level minus the DOWNTIME (configured in menu UPS MODEL & SYSTEM, default is 3/6 minutes).



Figure 58: HTTP - Job Editor / Function

In this example a RCCMD Shutdown is configured for the event *Powerfail*. The shutdown signal should be send after 5 minutes (300 seconds). Click the „Apply“ button after you have finished the configuration. Save your settings via the menu „Save Configuration“ and execute the „Save, Exit & Reboot“ function.

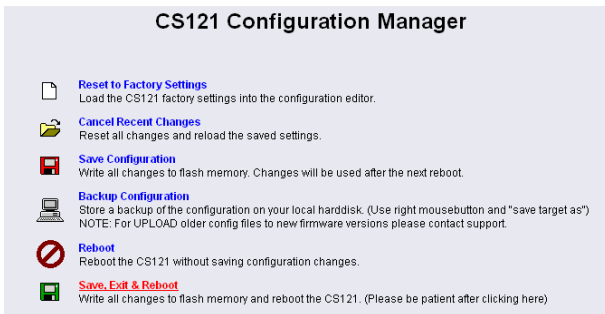

Figure 59: HTTP – CS121 Configuration Manager

We recommend to test the configuration prior of the implementation of the shutdown function into a live-system. Click into the Event Editor of *Powerfail* the "Test" button (Job Type: RCCMD SD).

Event Editor
Event: 'Powerfall'

Event Jobs for 'Powerfall'						
		Job Type	When	Parameter 1		Parameter 2
1	Edit	Del	Test	Log	P100	Powerfall
2	Edit	Del	Test	RCCMD Trap	0	Powerfall on #MODEL. Autonomietime #AUTONOMTIME min.
3	Edit	Del	Test	RCCMD SD	B300	192.168.202.88 6003

[Add new job](#) [Test this eventjob.](#)
[Back to event overview](#)

Figure 60: HTTP – Event Editor / Test

After you have clicked the “Test” button (Attention! The shutdown will be executed immediately without consideration of the defined delay), the following message will be displayed:

Job Test Page

Job Details:

Job type: RCCMD SD
Parameter 1: 192.168.202.88
Parameter 2: 6003
Parameter 3: (null)

Result: Command sent. Please wait some seconds and check the [CS121 logfile](#) for detailed results.

[Back to 'Powerfall' jobs](#)
[Back to event overview](#)

Figure 61: HTTP – Job Test Page

You can see the successful sending of the signal into the “AlarmLog”:

AlarmLog

```

01/02/1970,01:00:18, Timeserver not used. Using default time 1970.
01/02/1970,01:00:36, UPSMAN on No UPS model defined has started
01/02/1970,01:01:22, configuration changed
10/23/2008,12:34:06, Synchronized with timeserver 129.6.15.29. OK
10/23/2008,14:53:12, UPSMAN on XANTO S 2000 has started
10/23/2008,14:54:16, configuration changed
10/23/2008,14:55:39, Synchronized with timeserver 129.6.15.29. OK
10/23/2008,14:55:47, UPSMAN on XANTO S 1000 has started
10/23/2008,14:57:51, UpsShutdown delay:1 OK
10/23/2008,14:58:03, General Alarm
10/24/2008,11:49:55, UPS RS-232 communication lost
10/26/2008,03:00:25, Daylight saving time finished. Clock switched from 03:00:00 to 02:00:00.
10/28/2008,13:03:55, configuration changed
10/28/2008,13:05:47, Synchronized with timeserver 129.6.15.29. OK
10/28/2008,13:12:46, configuration changed
10/28/2008,13:14:09, Synchronized with timeserver 129.6.15.29. OK
10/28/2008,13:14:28, UPSMAN on No UPS model defined has started
10/28/2008,13:15:33, configuration changed
10/28/2008,13:16:56, Synchronized with timeserver 129.6.15.29. OK
10/28/2008,13:17:14, UPSMAN on No UPS model defined has started
10/28/2008,13:17:25, RCCMD is connecting to 192.168.202.88:6003 (RccmdConn01)
10/28/2008,13:17:25, RCCMD finished to send. OK (RccmdConn01)
  
```

[Download as CSV file \(Use right mousebutton and "save target as"\)](#)
[Delete this logfile](#)
 page generated: 28.10.2008 13:17:37

Figure 62: HTTP – AlarmLog

4.4.5 Automatic Reset of the Redundancy Alarm

You can use the function „Send RCCMD cancel shutdown“, to discard a previously sent shutdown automatically. If a shutdown was suppressed, because of the existing redundancy at this point of time, but the problem was solved at the UPS intermediate, you can reset the shutdown with the function „Send RCCMD cancel shutdown“. The client, which received the shutdown, will be encouraged to reset it.

This command can be set individually into your CS121, UPSMAN or BACS WEBMANAGER Events/Alarms configuration, but makes sense only, if the event, which will send the command, is true, if the UPS is back in normal condition. For this the events „POWER RESTORED“, „BATTERY LOW OFF“, „UPSMAN STARTED“ and „GENERAL ALARM OFF“ are suitable, if they are provided from your UPS into the CS121. The job „Send RCCMD cancel shutdown“ would be set into these all-clear events, so that e. g. at restart of the UPS, the event „UPSMAN STARTED“ would reset the accordant RCCMD client automatically.

Alternative: Should the job „Send RCCMD cancel shutdown“ not be present into your CS121, UPSMAN or BACS WEBMANAGER, you can use the job „Send RCCMD shutdown to remote client“ or rather „Send RCCMD execute to remote client“ alternatively.

The parameter „WAKEUP“ got the same function like the „Send RCCMD cancel shutdown“ and resets the redundancy alarm of a RCCMD Client into initial state. For this the events „POWER RESTORED“, „BATTERY LOW OFF“, „UPS MAN STARTED“ and „GENERAL ALARM OFF“ are suitable too, to configure the function „Send RCCMD command to remote client“ with the „WAKEUP“ command.

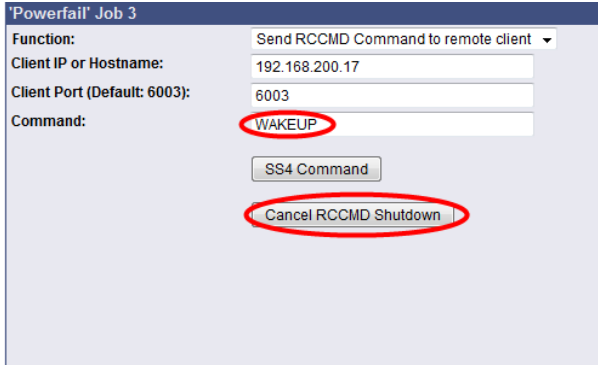

Figure 63: HTTP – Job Editor RCCMD WAKEUP

Click into the CS121 menu “Events/Alarms” onto “Power restored” and add a new job. Select the function “Send RCCMD command to remote client”, set the accordant IP address of the RCCMD client and click the “Cancel RCCMD Shutdown” button.

```

01/05/2010,14:59:54, RCCMD: RcvThreadUdp started
01/05/2010,14:59:54, RCCMD: RCCMD Listen Mode started.
01/05/2010,14:59:54, RCCMD: SendThreadCheckUpsman started
01/05/2010,14:59:54, RCCMD: RCCMD Trap client logged on to 192.168.222.177
01/05/2010,14:59:54, RCCMD: RCCMD Trap client logged on to 192.168.222.246
01/05/2010,15:01:01, RCCMD: RCCMD Trying to start program/job: ".\message.bat" "UPS MAN Notification
01/05/2010,15:01:01, RCCMD: RCCMD program/job: ".\message.bat" "UPS MAN Notification [192.168.222.177]
01/05/2010,15:01:03, RCCMD: RCCMD message received from 192.168.222.177
01/05/2010,15:01:04, RCCMD: Shutdown suppressed, redundancy-level = 1, failure count = 1.
01/05/2010,15:01:04, RCCMD: RCCMD Trying to start program/job: C:\RCCMD\ShutdownSuppressed.bat
01/05/2010,15:01:04, RCCMD: RCCMD program/job: C:\RCCMD\ShutdownSuppressed.bat executed. OK
01/05/2010,15:02:06, RCCMD: RCCMD Trying to start program/job: ".\message.bat" "UPS MAN Notification
01/05/2010,15:02:06, RCCMD: RCCMD program/job: ".\message.bat" "UPS MAN Notification [192.168.222.177]
01/05/2010,15:02:06, RCCMD: RCCMD message received from 192.168.222.177
01/05/2010,15:02:09, RCCMD: RCCMD message received from 192.168.222.177
01/05/2010,15:02:09, RCCMD: WAKEUP command received from 192.168.222.177.
01/05/2010,15:02:09, RCCMD: WAKEUP IP 192.168.222.177

```

Figure 64: HTTP – Job Editor RCCMD WAKEUP

4.4.6 RCCMD Message

With this job the user can combine and configure a text message with RCCMD event. Text messages can be sent to RCCMD receivers. This makes it possible to send text messages via RCCMD (version 2 or higher) to a Windows 2000 server or a UNIX computer, using the “NET SEND” or the respective “WALL” method. The problem with notifying network users on different operating systems is therefore solved.



Note: The corresponding RCCMD clients must be running with RCCMD version 2. RCCMD version 1 can only execute e.g. a shutdown as more than one action are not supported by version 1. Please contact your UPS dealer if you want to use these functions.

4.4.7 RCCMD Execute/Command

This RCCMD signal will cause any RCCMD receiver (e.g. another CS121, RCCMD client or SITEMANAGER, SITESWITCH4) to execute a command or program.

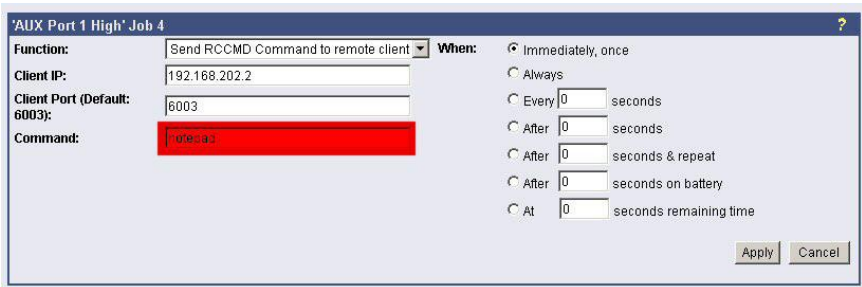

Figure 65: HTTP - Job Editor: RCCMD execute/command

Any CS121, SITEMANAGER, SITESWITCH can also act as an RCCMD listener; see the following examples:

Example of use 1: CS121-adapter as RCCMD-listener

If it is necessary to execute a command with parameters or a user defined script then these commands must be prepared as an executable batch on the RCCMD client.

The following example toggles the state of AUX output port 2 to high. To ensure that the above command works with a CS121 as RCCMD client the following four criteria must be met:

- Enable RCCMD Listener and set RCCMD Listener Port in menu "Network & Security".
- Add IP of UPSMAN sender in the SNMP community of the CS121-RCCMD client (see also section "SNMP")
- Target AUX port must be set to "use as Output" (menu AUX, see according section)
- The send RCCMD Command must match the settings of the CS121 RCCMD listener client.

See the UPSMAN User Manual for setting up this job on a computer running UPS Management Software.

Example of use 2: CS121-adapter switches an output

CS121 receives an external RCCMD signal to switch an output at the SS4 (Power Switch) which is connected to the AUX of a CS121.

If you want to send from a CS121, UPSMAN, SITEMANAGER II, SITEMONITOR II, SITESWITCH 4 or any other RCCMD sender a signal to any other RCCMD client e.g. to switch at its AUX port an output, please follow the example below.



Note: To let the receiver act as RCCMD listener, same basic settings in menu "Network & Security" are necessary: Please ensure that the option "RCCMD Listener" is enabled and the RCCMD Listener port is specified. (Usually the listener port is 6002)

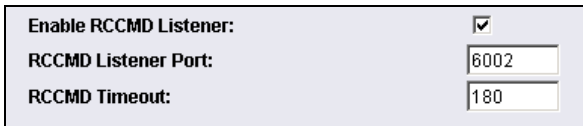

Figure 66: HTTP – Enable RCCMD Listener

Generally there are 3 commands which can be transmitted from any RCCMD Sender:

Switch Output (AUX): Syntax: |UPSCMD| 20000 |x, y"

where "x" is the port number from 1-8 (4 ports for CS121 AUX, SENSORMANAGER and SITESWITCH and there are 8 ports for the SITEMANAGER)

y=1 => switch on

y=0 => switch off

"20000" is the command to switch outputs. (for other commands please contact GENEREX support)

Syntax examples:

```
|UPSCMD|20000|1,1 = Output 1 on
|UPSCMD|20000|1,0 = Output 1 off
|UPSCMD|20000|2,1 = Output 2 on
|UPSCMD|20000|8,0 = Output 8 off
```

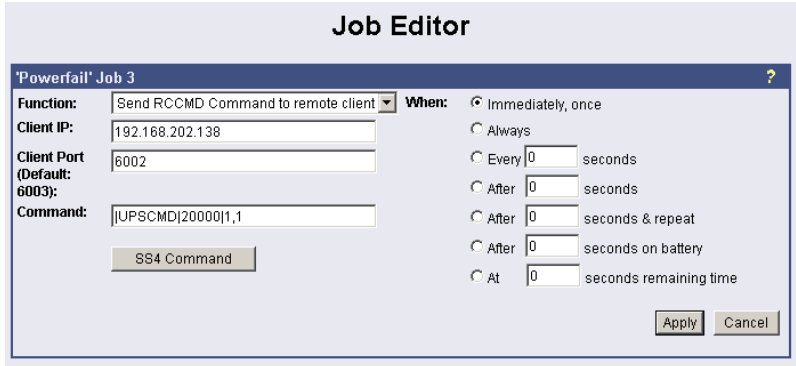

Figure 67: HTTP - Job Editor: RCCMD-Command

If you want to send a signal from a RCCMD client, e.g. UPSMAN or RCCMD Software, to switch an AUX port of a CS121, do the following:

C:\RCCMD\

```
rccmd -se "EXECUTE |AUX|1|1" -a 192.168.202.165 -p 6002
```

ATTENTION! The blank after the "Execute" is important!

Common syntax for the switching of AUX ports:

```
|AUX|1|0 Port1, set to low
|AUX|1|1 Port1, set to high
|AUX|2|0 Port2, set to low
|AUX|2|1 Port2, set to high
|AUX|3|0 Port3, set to low
|AUX|3|1 Port3, set to high
|AUX|4|0 Port4, set to low
|AUX|4|1 Port4, set to high
```

- **Confirm a digital alarm** : You can also use this syntax to e.g. confirm alarms for digital inputs (e.g. Fire-alarm, door open, air-condition failed, etc.) which you see in the UNMS software as "New Alarm". E.g. if your UNMS software shows an active alarm and you want to "acknowledge" this alarm by a switch with you connected to a CS121 or SITEMANAGER, then you can use the following syntax to program your device to send an "ACK" signal to the receiver. After this your UNMS will show "Alarm acknowledged – recovery action in progress".

Syntax : |UPSCMD|20001|x

where x is the Portnr. (1-8). („20001" is the ACK command for digital signals)

Syntax example: |UPSCMD|20001|2

This command confirms the Digital-Alarm 2 on a SITEMANAGER, SITEMONITOR, SITESWITCH or CS121 AUX Inputs.

- **Confirm an analog alarm** : The way it works with the ACK of analog alarms like Temperature thresholds exceed on the UNMS.

Syntax : |UPSCMD|20002|x

where x is the Portnr. (1-8). („20002“ is the ACK command for for analog signals)

Syntax example: |UPSCMD|20001|4

This command confirms the Analog-Alarm 4 on a SITEMANAGER, SITEMONITOR, SITESWITCH or CS121 AUX Inputs.

4.4.8 UPS shutdown

This event action enables an UPS shutdown. It is possible to configure when to send a shutdown signal to the UPS in case of an e.g. battery low, fire alarm or if a complete power down is wanted.

 Attention: This command will cut off the power supply – only for UPS which support this function!

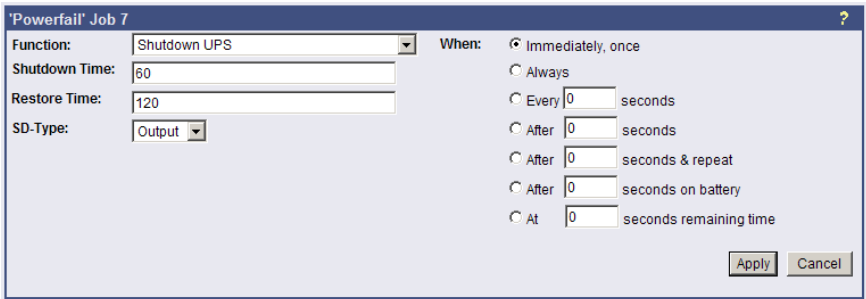



Figure 68: HTTP - Job Editor: Shutdown UPS-Job

The example above configures that 60 seconds after the event powerfail has occurred, the UPS is initiating a shutdown and the UPS waits another 120 seconds after the event powerfail is gone (power restored), before the UPS start up is initiated.

4.4.9 Wake On LAN (WOL)

This function sends data packages to wake up other workstations into a local network. Use this functions into the event "UPSMAN started". You can also use the event "Power restored".

 Note: Not all network cards are supporting this function. Some cards require a password. Activate this function into the BIOS settings of the target workstation.

 Note: If you want to send WOL signals in different sub-networks, it's required, that the switch, the CS121 and the workstation are defined with "Autosensing"!

'Powerfail' Job 7

Function: Send Wake-On-LAN Magic Packet

MAC Address:

Password:

When:

- Immediately, once
- Always
- Every seconds
- After seconds
- After seconds & repeat
- After seconds on battery
- At seconds remaining time

Apply Cancel

Figure 69: HTTP - Job Editor: Wake On LAN

4.4.10 Scheduled Actions

In this menu you can schedule actions for the CS121 like switch on/off UPS, execution of battery tests, switch on/off bypass mode or the periodical sending of emails with attached log files etc...

Please check the time and timeserver settings!
A correct internal adapter clock is necessary for scheduled actions.

Scheduled Actions

	Next Occurrence	Frequency	Action	
1	11.01.2007 14:00:00	daily	Self Test	edit delete
2	12.01.2007 10:00:00	weekly	Full Test	edit delete

Add new action

Refresh list
Save list to flashdisk

Figure 70: HTTP – Scheduled Actions

After you clicked the “Add new action” button, you can define new actions for the CS121. You can select the following options for the execution of an action:

- Once
- Daily
- Weekly
- Monthly



Note: Please check the time and timeserver settings! A correct internal adapter clock is necessary for scheduled actions!

4.4.11 CS121 for Transfer Switches

The CS121 is used from time to time for automatic transfer switches (ATS) too. The graphical display depends on the manufacturer.

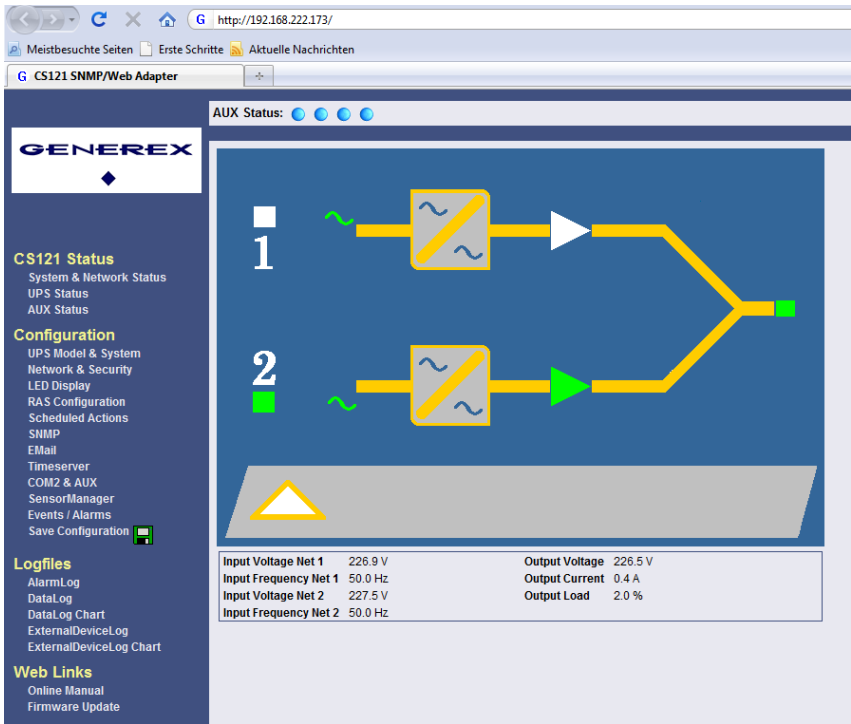

Figure 71: HTTP – Status Page Socomec Transfer Switch

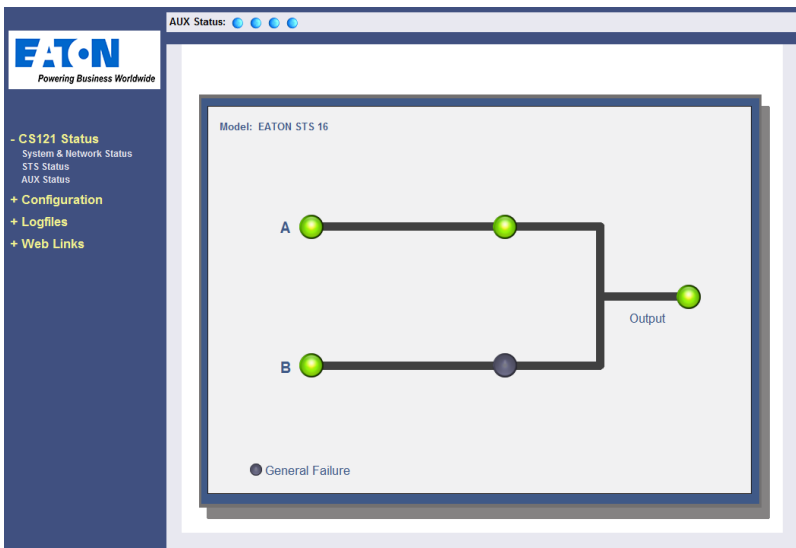

Figure 72: HTTP – Status Page Eaton Transfer Switch

All ASYS, AEG and PILLER transfer switches are using the extended RFC1628 SNMP MIB ([Download](#)). The models SOCOMECS and LTM got their own MIB (STS LTM MIB), which is available as download from our website:

5. Adapter Software Updates (Firmware)

Usually the CS121-Adapter already contains a specified firmware-version and does not need to be updated unless you have problems or you find a update recommendation on our website. (use firmware online update link on CS121 page).

If you have connected your CS121 via LAN a link at the Webbrowser configuration page (CS121 Firmware Update) indicates you with red or green coloured information whether you should perform a Firmware-Update or not.

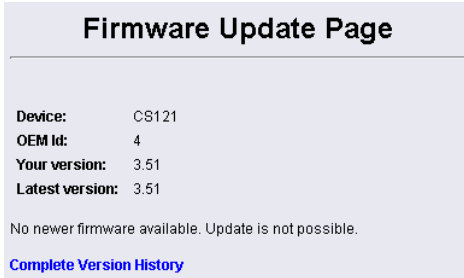

Firmware Update Page

Device:	CS121
OEM Id:	4
Your version:	3.51
Latest version:	3.51

No newer firmware available. Update is not possible.

[Complete Version History](#)

Figure 73: HTTP - Firmware Update Page



Note: We strongly recommend to update any firmware lower than 2.69 to the actual version!

All actual Firmware-updates are provided at www.generex.de download page.



Note: Any interruption of a firmware upload may damage your adapter. If this is the case, you have to reformat the adapter with special software See section "Firmware Recovery". or contact your UPS software support for more information.

The boot procedure of the CS121-adapter performs several steps:

- First, the firmware is going to be uncompressed.
- Starting firmware
- Control process called UPSMAN is going to be started and USV connection is trying to established
- Services e.g. Webserver etc. started

There are two ways to update your firmware-version, by using the Setup-tool or via FTP.

5.1 Firmwareupdate via Setup-tool

Firmware updates are available for free at www.generex.de. Download the specified version (**mind your OEM ID**) and follow up the setup-procedure. If necessary, consult your UPS dealer for further information.

5.2 Firmwareupdate via FTP

You can download the update file from www.generex.de or from your manufacturer site.

A firmware update via FTP does not change the operating system of the CS121 only. If you want to change the manufacturer data, please contact your UPS dealer directly.

5.3 Firmware flash renewal and recovery

General information regarding the upgrading process of the CS121 - Known Problems and Preliminary Precautions:

- Any update will cause a deletion of all former settings. The adapter must be reconfigured after the update. The current settings information can be saved by using an FTP connection to your adapter to save the upsman.cfg file in the flash directory to a local directory. This file contains all of the information about the current CS121 settings in a formatted text. Do not copy this file back onto the adapter after the update as a replacement for the new upsman.cfg. The information must be entered back into the settings using the adapters configuration interface. Note that the http interface often contains newer settings options that are not yet implemented in the telnet and terminal interfaces.
- Any recovery should be made on the default IP Address 10.10.10.10. Put DIP Switch 1 and 2 in the OFF position before starting.
- Please avoid the use of routers and switches between your computer and the CS121, if available use Hub (recommended) or a direct line (Ethernet-cross-cable).

Instructions for recovery procedure:

In case the CS121 is not running, has any defect or other problem, please put dip switch 1 to OFF (Dip 2 should be always OFF) and follow the procedure below:

1. Before starting the update, unplug the adapter from the power supply (slot cards have to be removed from the slot).
2. Set a route to default IP-Address. Command syntax on your windows computer: "route add 10.10.10.10 <your IP address>". Also note that the flash tool can also be used to set the route for you by checking the set route check box in the update interface.

5.4 How to get the "upsman.cfg" from a CS121 to your computer via FTP

Click on the web-interface of your CS121 into the configuration menu bar the „Save Configuration“ button. Click the „Backup Configuration“ icon with the right mouse button, select „Save Target As“ and choose the path of your hard disk, where you want to store the „upsman.cfg“ data.

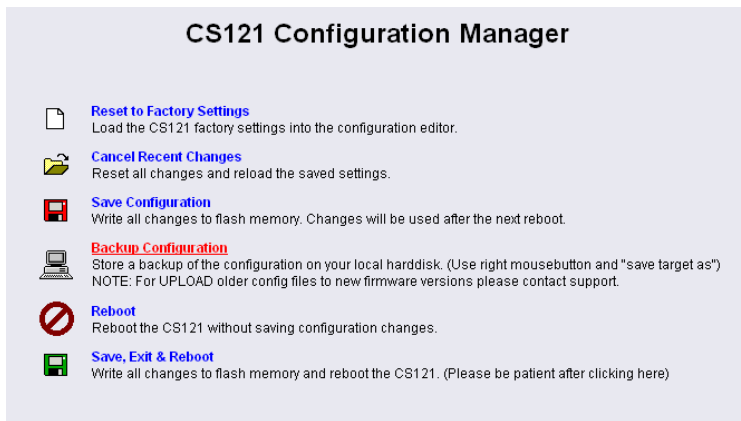

Figure 74: CS121-Configuration Manager

Via FTP: Enter the following into the address field of a web-browser: <ftp://<ip-address>> of your CS121>. Enter the username *admin* and the password *cs121-sntp*. You will find the „upsman.cfg“ into the „flash“ folder.



Figure 75: CS121-FTP Access

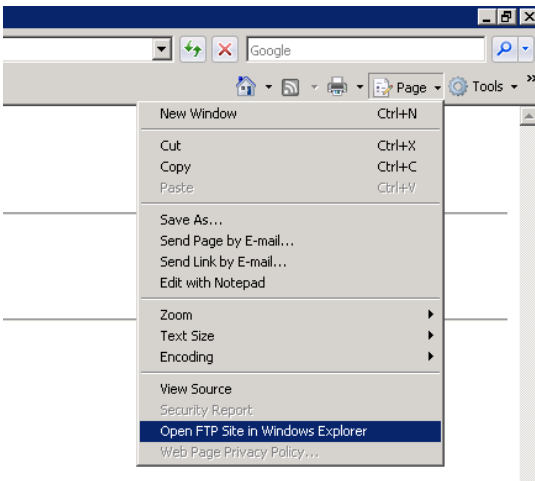

Figure 76: CS121-FTP Context Menu

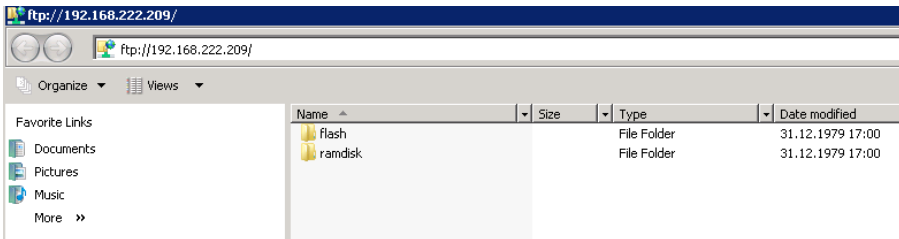

Figure 77: CS121-FTP Folders

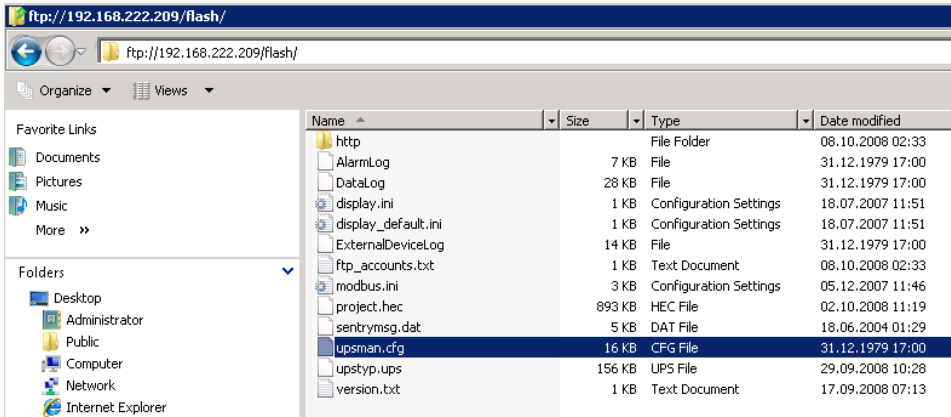

Figure 78: CS121-FTP Upsman.cfg

After you have updated your CS121, please open the „new“ and the stored „upsman.cfg“ in an editor. Now check, if the parameter of the new data are present into the stored data. If not, you **need** to copy the missing parameter of the new data into the stored „upsman.cfg“.

Now you can overwrite the „upsman.cfg“ into the „flash“ folder via ftp.

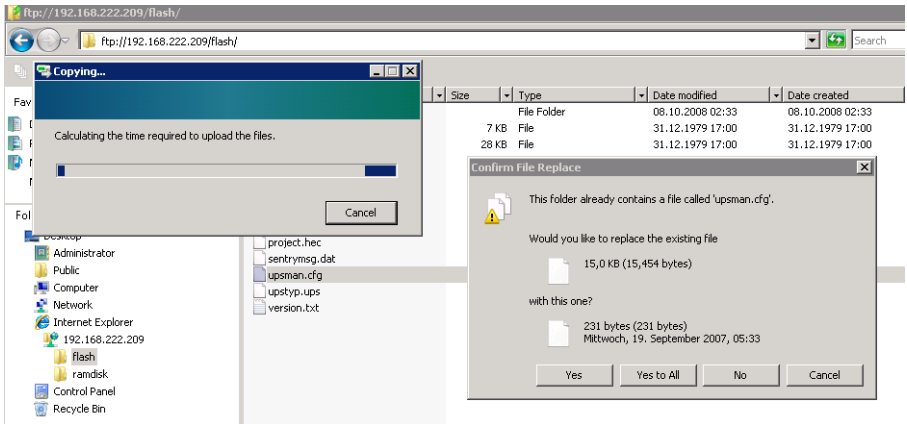

Figure 79: CS121-FTP File Replacement

Just **reboot** (do not select „Save, Exit & Reboot“) the CS121 via web-browser.

CS121 Configuration Manager







-  **Reset to Factory Settings**
Load the CS121 factory settings into the configuration editor.
-  **Cancel Recent Changes**
Reset all changes and reload the saved settings.
-  **Save Configuration**
Write all changes to flash memory. Changes will be used after the next reboot.
-  **Backup Configuration**
Store a backup of the configuration on your local harddisk. (Use right mousebutton and "save target as")
NOTE: For UPLOAD older config files to new firmware versions please contact support.
-  **Reboot**
Reboot the CS121 without saving configuration changes.
-  **Save, Exit & Reboot**
Write all changes to flash memory and reboot the CS121. (Please be patient after clicking here)

Figure 80: CS121-Reboot

At the reboot, the stored „upsman.cfg“ will be load and the CS121 will obtain the configuration prior of the update.

6. Additional Software

6.1 RCCMD

RCCMD is the client module for integrating an unlimited number of computers of any operating system into an UPSMAN managed UPS facility. The main purpose is to transmit shutdown signal or messages to RCCMD clients in other networks or on other OS.

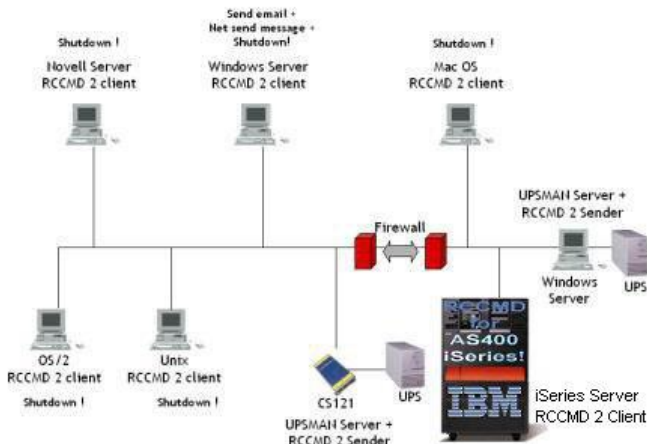

Figure 81: RCCMD - Overview

The RCCMD Software got his own user manual. Please follow this link to get it:

http://www.generex.de/generex/download/manuals/manual_RCCMD_Win_Unix_Mac_en.pdf

6.1.1 RCCMD with SSL for Windows

The Secure Sockets Layer (SSL) protocol is a cryptographic protocol that provides security and data integrity for communications over TCP/IP networks.

Use your Web-browser to navigate to the address of your UPS Web-Manager. Click the “Network & Security” configuration button and enable the SSL network feature.

Figure 82: RCCMD SSL Settings

The SSL network feature requires correct time settings, so it is required to configure a timeserver. Click the „Timeserver“ configuration button and enter the address of at least one timeserver.

Figure 83: Timeserver Settings

Click the „Save Configuration“ button and the „Save, Exit & Reboot“ button to confirm your settings.

CS121 Configuration Manager

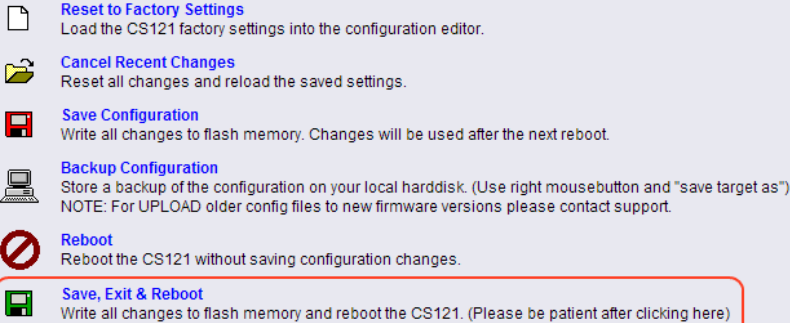

Figure 84: Settings Confirmation

6.1.2 RCCMD with own SSL certificates

In this chapter we will describe, how to use an own SSL certificate with RCCMD, e. g. OpenSSL (<http://www.openssl.org>):

Be your own CA

Using OpenSSL it is quite simple to become your own CA. Just run:

```
CA.pl -newca
```

Done! Just ensure, that you select a useful CN (common name)!

Create your RCCMD certificate

You need to create your certificate for RCCMD now. As it will use it for verification, it should contain the same useful common name (CN), that you selected for the CA. The private key must not be encrypted to let the RCCMD Client (service) start without trouble. Therefore we use the "--nodes" option and the "-newreq" command:

```
CA.pl -newreq -nodes
```

Sign with your CA:

```
CA.pl -sign
```

Now create an empty file named "rccmd.pem" and copy the cert information of *newcert.pem* (rccmd certificate), *newkey.pem* (private key) and *cacert.pem* (CA) into it. Please note, that the exact copying is required to use it without trouble!

Use your own RCCMD certificate

Do the following steps at the RCCMD Client and every sender (e. g. UPS Web Manager):

- Backup the existing "rccmd.pem"
- Replace the existing "rccmd.pem" with your own
- Restart the RCCMD Client
- Restart the RCCMD Sender

6.1.3 RCCMD client as relay station

In order to reach a bigger number of RCCMD receivers, the adapter needs to be operated as relay station. The receiver will be configured so that it will receive a RCCMD signal and this signal is then used to start a batch file, which then starts even more RCCMD sender signals.

Please take a look into the RCCMD Software user manual for further information.

6.1.4 License regulations

Please note that in order to use these functions legally, the corresponding RCCMD program is installed and started from the UPS-Management Software CD resp. see www.generex.de download page for the latest version. (see above) The license code can only be used **once per installation**. If more computers need to be added to the shutdown process, additional licenses are required. The CS121 package does usually contain a single license for RCCMD to shutdown 1 computer. For more computers to shutdown you have to order separate RCCMD client licenses. If you want to shut down more than 50 clients in one company or organisation, please contact your UPS dealer and order an enterprise license. Then you will get one RCCMD license for all clients only.

6.2 jChart

jChart is a GENEREX Web 2.0 Control Chart for all web-browsers, which simple visualizes the data log file of the CS121 (since CS121 firmware version 4.27).

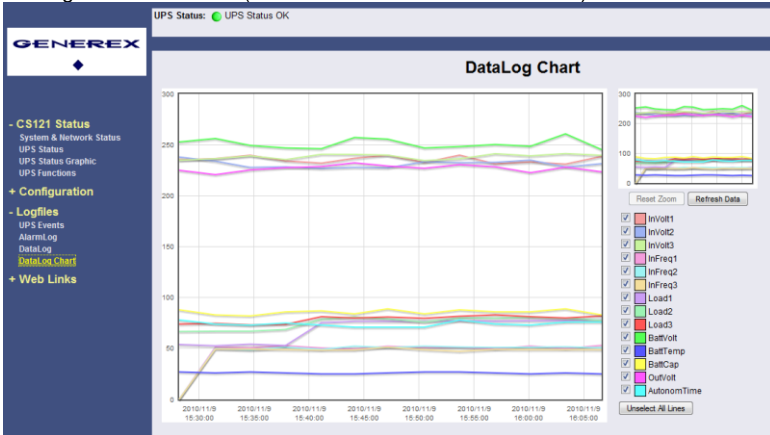

Figure 85: jChart Display of the CS121 Data Log

Position the mouse cursor accordingly, if you want to identify an additional coloured line of a desired point in time. If a timeserver was defined, the data prior of 2000 will be filtered automatically.

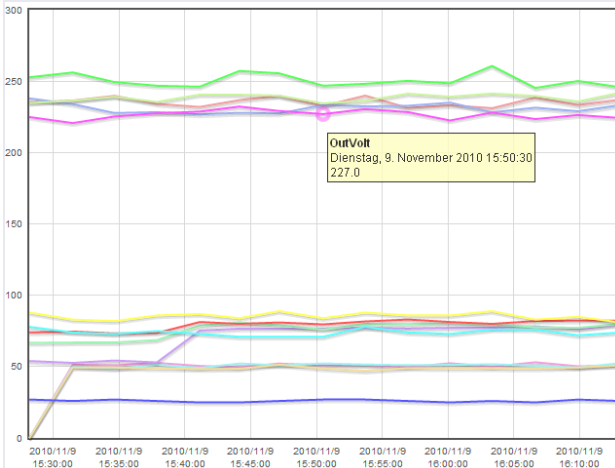

Figure 86: jChart Display of a Measurement Value

To display the desired values into the chart only, click the “Unselect All Lines” button and check the accordant variables.

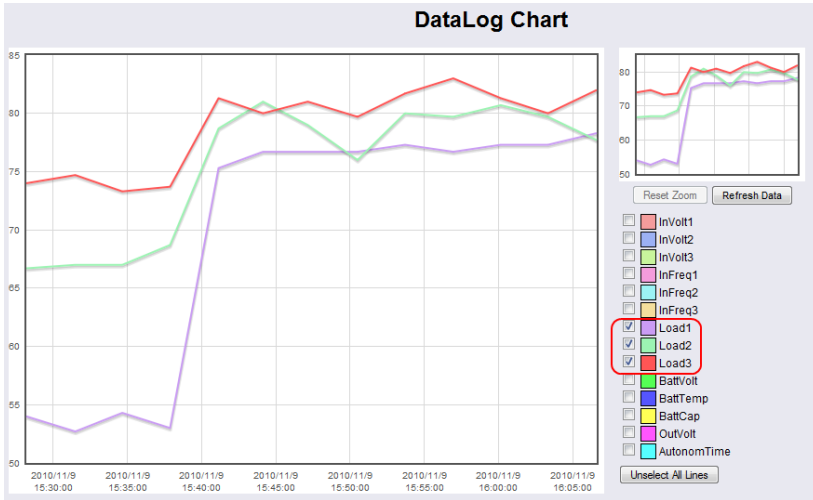

Figure 87: jChart Display of the Loads

To increase a desired area, click the left mouse button into the area and drag an accordant rectangle from the upper left side to the lower right side.

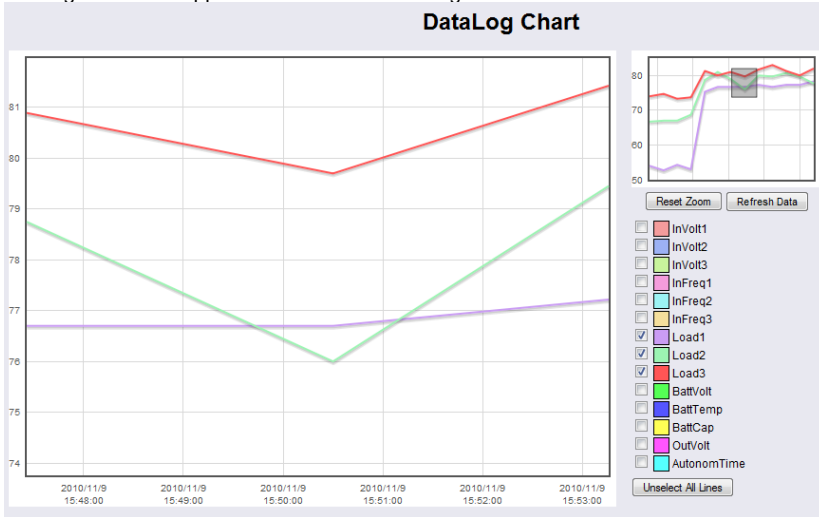

Figure 88: jChart – Zoom-In of an Area

Click the “Reset Zoom” button, if you want to get back to the initial state. If you want to change the colours for the values, click the coloured box prior of the variable.

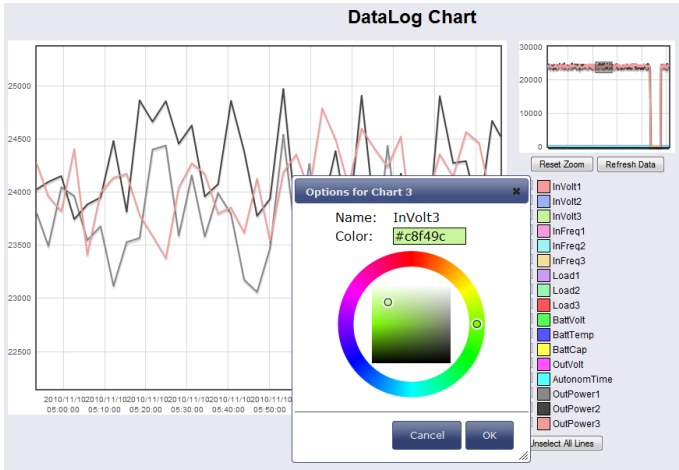

Figure 89: jChart – Colour Selection

6.3 gChart

gChart is a GENEREX plug-in for the MS Internet Explorer available as a free download from the GENEREX web site. Quickly and easily visualise all of the CS121-adapter logfile using Genex's ActiveX graphical log controller GChart when using the Internet Explorer. Discover UPS problems more easily and optimise system tuning more rapidly. Navigate through the data with the mouse using functions like zoom and pan with continuous motion in real time and query interpolated data values by clicking in the areas of interest. Customize the view by moving or toggling off the legend, toggle off and on the data grid and also switch individual log values on and off.

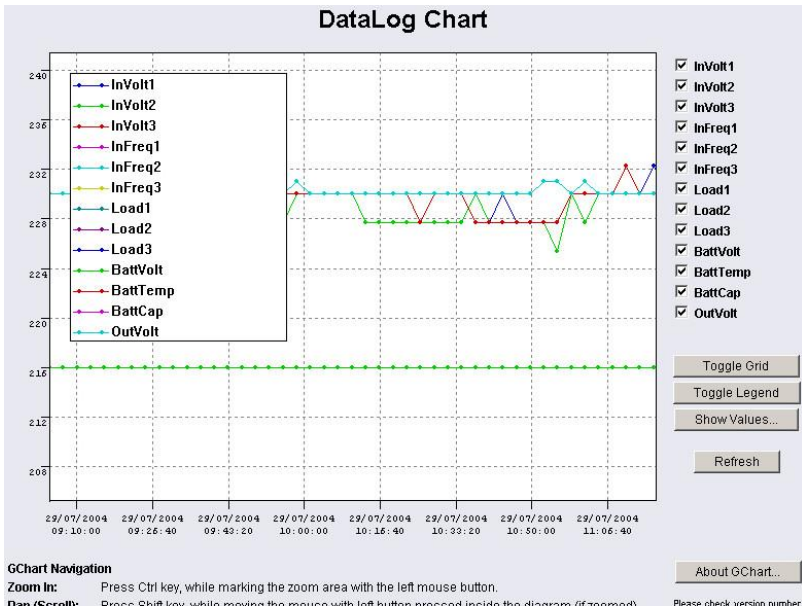

Figure 90: gchart plug-in for the internet explorer

Get the gChart experience now by visiting our online CS121 at: <http://q01.generex.de/> and be sure to follow the GChart logfile links.

In order to activate this function, the following adjustments in the Internet Explorer Options are required:

Click via the menu „Tools“ into the Internet Options.

Select the tab „Security“.

Click the „Trusted Sites“ icon, than the „Sites“ button and add the desired IP address.

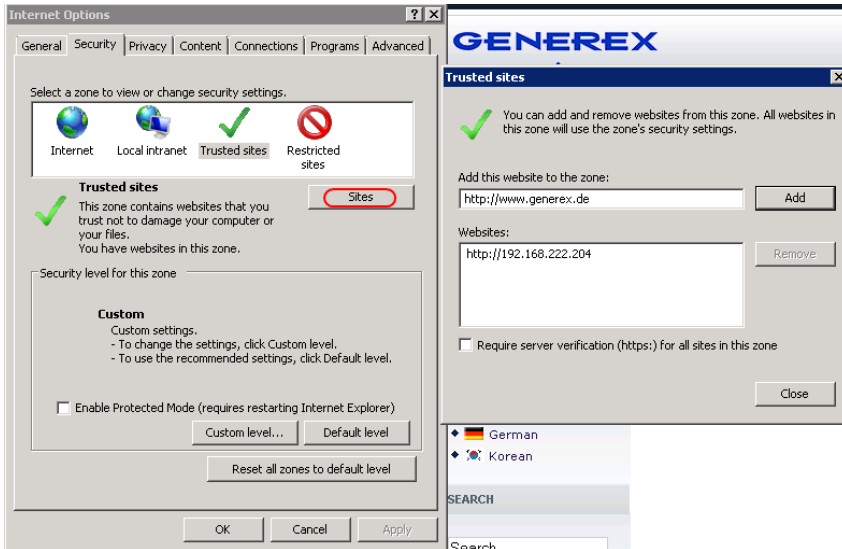

Figure 91: Internet Options of the internet explorer

Close the opened windows via „Close“ and „Ok“.

Click into the Internet Options and Security again. Click via „Custom level...“ into the Security Settings of the Trusted Sites Zone.

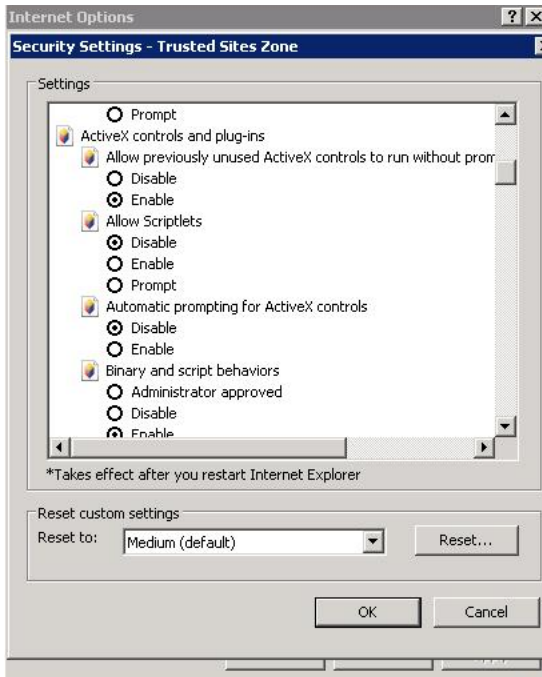

Figure 92: Security Settings

Activate the following options:

- Allow previously unused ActiveX controls to run without prompt
- Download unsigned ActiveX controls
- Initialize and script ActiveX controls not marked as save for scripting
- Run ActiveX controls and plug-ins

Close the opened windows via „Ok“ and restart your Internet Explorer with the desired site.

6.4 UPS monitor (UPSMON)

UPS-Monitor (UPSMON) is the graphical monitoring and command interface application for UPSMAN and is available in standard and custom interfaces.

In order to display the UPSMAN provided data via the network customer friendly, the modules UPSMON and JAVAMON are delivered for free. The UPSMON is a client for all Microsoft-platforms, whereas the JAVAMON can be started on all operating systems, that support JAVA. A LAN, WAN, or the Internet (TCP/IP) connection can be used as a connecting network between UPSMAN and the management interfaces. Both graphic interfaces can be customised to the demands of the UPS manufacturer, that's why the UPSMON appearance differs for almost every UPS maker product. This allows for an adaptation of all UPS systems with all different kinds of functions. UPS systems, with serial interfaces often incorporate of a variety of measured values and status information. Those can be displayed using overview or block diagrams. Other devices, such as diesel generators or extra measuring units can be integrated with this management software via the network. A separate password protected screen can be created, if the devices also support remote controlling commands. The values

and status information, which are stored in the UPSMAN log file, can be requested from every computer with an installed UPS monitor module.

Features:

- Monitoring of all UPS systems that are connected in the network via UPSMAN and respective SNMP adapter
- gCHART dynamic visual log file graphic tool
- Remote controlling of all UPS systems via the network
- Graphic display of the UPS input data (voltage, power)
- Read out and display of the UPSMAN event-log files
- Programming of the UPSMAN scheduler
- Graphic screens containing all UPS information also under UNIX, MAC (JAVAMON)

7. CS121-Enhancements, Field of applications

7.1 SiteSwitch4 (SS4) and SiteSwitch4AUX (SS4AUX)



Figure 93: SideSwitch4 and SS4 AUX

SITEWITCH4AUX is a high-performed extension of the CS121-adapter but can also be operated as stand-alone solution with the possibility to connect to UPS or UPS-similar devices. The SITESWITCH has 4 power outputs sockets, which can be configured by the event settings of the CS121 or any other RCCMD compliant sender like SITEMANAGER, SITEMONITOR.

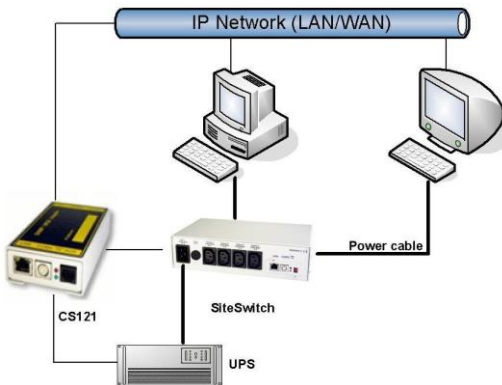

Figure 94: CS121-Installation with SideSwitch4

Using the integrated Webserver, the SITESWITCH 4 enables the monitoring and the remote control of its 4 power outputs. The power sockets can be switched on and off individually. This can be done either manually via the HTML browser interface or UPSMON or automatically using the EVENT manager of the CS121 - or any other network CS121 or compatible device. When executing the action using the EVENT manager of the CS121, the power switching can be preconfigured to run with delays or to run on a schedule. Both the UPSMON time scheduler and the HTML time scheduler can be used to configure a power switching time schedule.

This task can also be achieved using the full version of the UNMS UPS Network Management Software.



Note: (only SS4, not SS4AUX) If you wish to use a UPS with your SS4 then you must install the appropriate CS121 Firmware on your SS4. The default Firmware on SS4 (OEMID 27) is for the usage without UPS, as standalone remote powerswitch. For UPS usage at the SS4 you must also be sure to set the Exchange COM Ports checkbox and then use the configuration cable (not included) to connect the SS4 with your UPS.

UPS Model & System Settings	
UPS Model:	[Dropdown]
Power (VA):	600
Load (VA):	600
Hold Time (min):	4
Recharge Time (h):	8
Baud Rate:	2400
Cable Type:	Serial
Exchange COM Ports:	<input checked="" type="checkbox"/>
UPS ID:	0
System Name:	CS-121
System Location:	Hamburg
System Contact:	Admin
Attached Devices:	UPS protected devices
Battery Installation Date:	18.06.2004

Exchange COM Ports
Check box for switching COM1 and COM2 on the CS121 adapter for enabling alternative cable connections.

Figure 95: Exchange COM Ports 1 & 2 for SS4

7.1.1 SS4 Feature overview

- 4 configurable powers sockets with a breaking capacity of 230V/8A
- Power socket status indicator via HTML, UPSMON, UNMS or SNMP
- Control via the internal CS121 or via remote CS121 or RCCMD compatible devices
- Remote control of the powers sockets via HTML Browser (Password protected)
- LED-Status of the power sockets
- Small metal casing with 1.5RU, designed for 19"-Rack Mountings (mounting frame included)
- High breaking capacity (8A), input with IEC 16A.
- Programmable power switching via the HTML and UPSMON Scheduler
- Delay of alarm (e.g. UPS alarms) triggered power switching on COM1 of the CS121

7.1.2 SS4 Contents

- SITESWITCH 4
- 16A IEC 230V power cable
- 2 mounting irons for 19"-Rack installation
- manual for SS4

The manuals are being constantly updated and therefore the reader is encouraged to check our website for a newer download version of the adapter manual. Check <http://www.generex.de> for manual updates.

7.1.3 SS4 Installation

The power consuming devices are connected to the SS4 using IEC 250 VAC/6A plug cables. The SS4 has 4 IEC 250VAC/6A chassis sockets that can be switched on and off separately. Special notice is to be given to the 8A threshold breaking capacity; exceeding this limit will cause the SS4 fuse to break leaving all connected devices without electricity.



Note: Due to errors that may cause the switched off power outlet to remain on it is necessary to conduct the following: Before connecting any power consuming devices with the SITESWITCH 4 or working on any power consuming devices already connected to the SITESWITCH 4, make sure

that the SITESWITCH 4 is not connected to the power supply by pulling its power cable out of the power socket.

Use the provided mounting irons to fix the SS4 into a 19" rack. Place the SS4 so that the front panel of the SS4 can be securely screwed onto the 19" rack housing while insuring also that the power cables can be connected from behind as well.

As soon as all of the power consuming devices are connected to the SS4, the IEC 16 power supply cable can be connected. Upon establishing power to the SS4, the green „POWER„ LED will light up, and the 4 „Power Socket Status LED“ one for each of the sockets should be unlit. This means that none of the sockets are being provided with power thus cutting the connected devices from the power supply.

The CS121 establishes a user interface for the SS4 for which the user has the option of using either UPSMON, Webbrowser, UNMS or an SNMP-Program. All communications take place either through a modem or network connection. Detailed information is covered in section 7.7.9 AUX and SS4 Settings.

7.1.4 SS4 - Technical data

Inputvoltage:	230V AC +/- 5%
Max. Power Input:	16A
Max. Power Output per socket:	8A (Load at cos phi 1)
Dimensions	260x180x60mm (BxTxH), with 19" : 1,5U
Operating temperature:	0-40°C/rel.Humidity0-95% non condensating

7.2 Sensor SM_T_COM

The SM_T_COM is a temperature sensor for the use with a GENEREX CS121. It has a range from -25° - 100° Celsius (-13° -212° Fahrenheit) and comes with a 1.8 meter cable for connecting to the CS121 COM2 port. The SM_T_COM is designed for monitoring and management of 19"- racks, UPS rooms, server and data center rooms and for industrial applications. Simple Plug' n Play connections insure that the sensor can be easily and safely installed.



Figure 96: The Sensor SM_T_COM

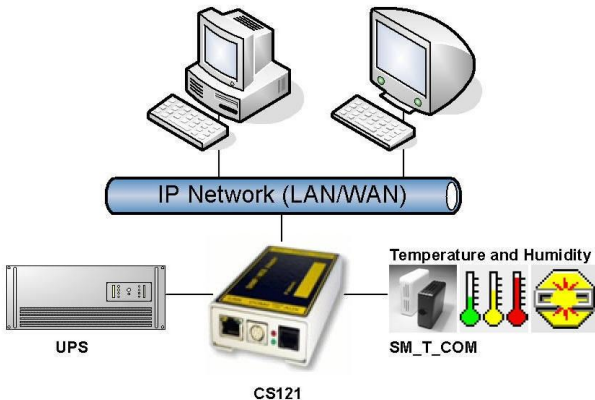

Figure 97: CS121-Installation with temperature SM_T_COM

The SM_T_COM (also available as SM_T_H – a combination of Temperature and Humidity) is a temperature sensor with an RS232 protocol which can be connected directly to the CS121 COM2 port. (Not BUDGET series).

The SM_T_COM shows the actual values on the CS121 Webserver screen and allows to trigger alarms, emails, messages in case the values exceed configurable thresholds. SM_T_COM is simply connected with the original CS121-TEMP cable (part of every CS121 SC and L) to the COM2. In the Webinterface COM2 & AUX you have to change to the COM2 mode to “SM_T_COM”, press “apply” and “save&exit” and reboot to start the CS121 with your new settings. The Configuration of thresholds and Events is made via the Event-configuration windows and the SM_T_COM configuration page.

7.2.1 SM_T_COM configuration

The screenshot shows the configuration page for the CS121. At the top, there are status indicators for UPS (green), AUX (green), and Sensor (green, blue, blue). Below this, the 'COM2 Settings' section includes a dropdown for 'COM2 Mode' set to 'SM_T_COM', a 'COM2 Baud Rate' of 38400, and 'COM2 Parity' set to 'None'. A note states: 'Please note: COM2 is always used for configuration as long as DIP switch 1 is off!'. The 'SM_T_COM Settings' section has a table with columns: Location, Unit, Threshold (Low), Threshold (High), and Offset. The 'Temp. Sensor 1' row shows 'Degree Celsius', '0.0', '100.0', and '0.0' respectively. Both sections have an 'Apply' button.

Figure 98: CS121- SM_T_COM Settings

Enter the desired values for the Threshold (low) and Treshold (high).

You can calibrate every sensor with the Offset, that means if you want to rise a measured value for 5°C, just modify the default range from 0.0 to 5.0. Therefore you are able to adjust the measurement values like a gauged thermometer.

You can define the following functions for SM_T_COM Events (see figure below).

The screenshot shows the 'Job Editor' window for the event 'SM_T_COM Sensor High'. The 'Function:' dropdown is set to 'Write to Logfile'. A list of available functions is shown, including 'Send an EMail', 'Send RCCMD Shutdown to remote client', 'Send RCCMD Message to remote client', 'Send RCCMD Command to remote client', 'Shutdown UPS', 'Switch AUX/SensorMan/UPS Output', 'Send RCCMD Trap', 'Send Wake-On-LAN Magic Packet', 'Send RAS Notification', and 'Send SMS with GSM modem'. The 'When:' section is set to 'Immediately, once'. There are options for 'Scheduled in 0 seconds', 'Every 0 seconds', 'After 0 seconds', 'After 0 seconds & repeat', 'After 0 seconds on battery', and 'At 0 seconds remaining time'. A note states: 'Actions will only be executed if event condition is still true after the specified seconds!'. 'Apply' and 'Cancel' buttons are at the bottom right.

Figure 99: CS121- SM_T_COM Functions

The CS121 firmware version 4.26.x provides the option to define threshold events for the analogue inputs. Click the “Configure Threshold Events” button into the CS121 “Events/Alarms” menu.

Device Status: ● UPS STATUS OK
Sensor Status: ● ● ●

Threshold Events

Threshold Events

1	SM_analogue 1<13.00	Edit Event	Delete Event	Edit Jobs
2	SM_analogue 1>47.00	Edit Event	Delete Event	Edit Jobs

Add Threshold Event

Variable: Battery voltage

Direction: Battery voltage

Threshold: Seconds on Battery

[Add as new event](#)

Figure 100: CS121-Configuration Threshold Events of analogue Inputs

In this example, a below threshold of 13 was defined for SM_analogue 1, in this case for the temperature in °C, which will appear into the Event Configuration, after you executed the “Save, Exit & Reboot” function.

Device Status: ● UPS STATUS OK
Sensor Status: ● ● ●

Event Configuration

Event Overview (Events 1-30 of 31)

Event	Disabled	Log	EMail	RCCMD Shutdown	RCCMD Message
1	<input type="checkbox"/>	1	0	0	0
2	<input type="checkbox"/>	1	0	0	0
3	<input type="checkbox"/>	1	0	0	0
4	<input type="checkbox"/>	1	0	0	0
5	<input type="checkbox"/>	1	0	0	0
6	<input type="checkbox"/>	1	0	0	0
7	<input type="checkbox"/>	1	0	0	0
8	<input type="checkbox"/>	1	0	0	0
9	<input type="checkbox"/>	1	0	0	0
10	<input type="checkbox"/>	1	0	0	0
11	<input type="checkbox"/>	1	0	0	0
12	<input type="checkbox"/>	1	0	0	0
13	<input type="checkbox"/>	1	0	0	0
14	<input type="checkbox"/>	1	0	0	0
15	<input type="checkbox"/>	1	0	0	0
16	<input type="checkbox"/>	1	0	0	0
17	<input type="checkbox"/>	1	0	0	0
18	<input type="checkbox"/>	1	0	0	0
19	<input type="checkbox"/>	1	0	0	0
20	<input type="checkbox"/>	1	0	0	0
21	<input type="checkbox"/>	1	0	0	0
22	<input type="checkbox"/>	1	0	0	0
23	<input type="checkbox"/>	0	0	0	0
24	<input type="checkbox"/>	0	0	0	0
25	<input type="checkbox"/>	1	0	0	0
26	<input type="checkbox"/>	1	0	0	0
27	<input type="checkbox"/>	1	0	0	0
28	<input type="checkbox"/>	1	0	0	0
29	<input type="checkbox"/>	1	0	0	0
30	<input type="checkbox"/>	1	0	0	0

[Events 31-31 >>](#)

[Configure threshold events](#)

Figure 101: CS121-Configuration Threshold Event for SM_analogue 1

7.3 **SENSORMANAGER & SENSORMANAGER II**

7.3.1 **General information**

If more than 1 or 2 environmental values are wanted to manage, than the SENSORMANGER (SensorMan) is your choice. This device is a data measurement and collecting unit which allows the individual measurement and monitoring of 8 analog measurement devices (0-10V) and 4 digital alarm inputs or 4 outputs (open collectors).



Figure 102: *Sensor Manager (SensorMan)*

The SENSORMANAGER is a system extension for the CS121 Professional, BACS WEBMANAGER, CS121 Mini und CS121_R_II. Universal Remote Sensor Control Box for the monitoring of temperature, humidity and many other types of sensors as well as for the the management of digital input/output signals. 8 analog inputs (0-10V), + 4 digital input and/or outputs (48 V 500mA). Digital Outputs are configurable as normally open or as normally closed. Digital input connections directly through sensor for some models or connect directly to the RJ11 socket. Convenient splitting plug available for attaching two sensors to one RJ11 socket.

Purpose:

- Monitoring of temperatures, humidity and other analog data in computer rooms with automated response to system alarms.
- Alarms can be individually configured and defined for trip contacts such as fire, smoke and intrusion, and minimum/maximum thresholds values can be set for analog devices such as humidity, temperature and pressure, fluid level, etc. – any sensor which transmits its values between 0- 10 V may be connected to a SENSORMANAGER.
- Data logging, logging of alarms, automatic shutdowns of network computers, and other actions can be set as reactions to critical alarms.
- All system operating and configuring can be done remotely via Web browser. The EVENT driven alarm management system of the CS121 informs the administrator of problems and may automatically switch off computers and other devices (Optional extensions: SITESWITCH 4 or SITEMANGER).
- The SENSORMANAGER is an extension to the CS121 Webmanager. If you want to connect any other computing device, please download the RS-232 protocol for the SENSOR MANAGER from our website and adjust your software to this communication type.

Important:

New firmware for your CS121 is available for download at: <http://www.generex.de>

7.3.2 Installation and Network integration

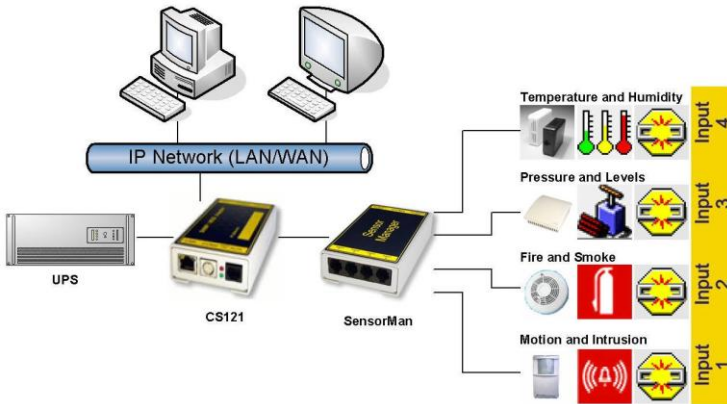

Figure 103: CS121-Installation with SENSORMANAGER

As shown in the figure above CS121 can also be applied to observe and react on alarms of the SENSORMANAGER-Inputs. Therefore, the CS121 COM2 port is connected and configured for the SensorManager's AUX- and Sensor-Input/Outputs. Within the CS121 configuration it is possible to define actions, which will be released from events of the SensorManager's devices.

Connecting the SENSORMANAGER Box

The SENSORMANAGER has to be connected with the original configuration cable (not included) of the CS121 to COM 2.

The sensors for the SENSORMANAGER may be connected direct to the socket Inputs 1-4 using an RJ12 cable. In this configuration you can only use up to 4 sensors. If you want to use all 8 analog inputs, you have to use a splitting plug (optional) or connect the sensors directly to the Channel Inputs as described above.

If you use the sensor type SM, you may connect a second SM sensor to the input of the first SM. You can not connect more than 2 SM sensors in line.

For connecting an alarm contact to the SM sensor, you may use the first or the second SM contact input/output, but not both. Only one digital input/output is available per socket.

OTHER SENSORS: If you use other sensors than SM, EE or TM, you must use a splitting plug in order to connect more than one sensor to a single INPUT of the SENSORMANAGER.

For setting up the sensors in the SENSORMANAGER make sure your configuration matches your sensor type, e. g. see example:

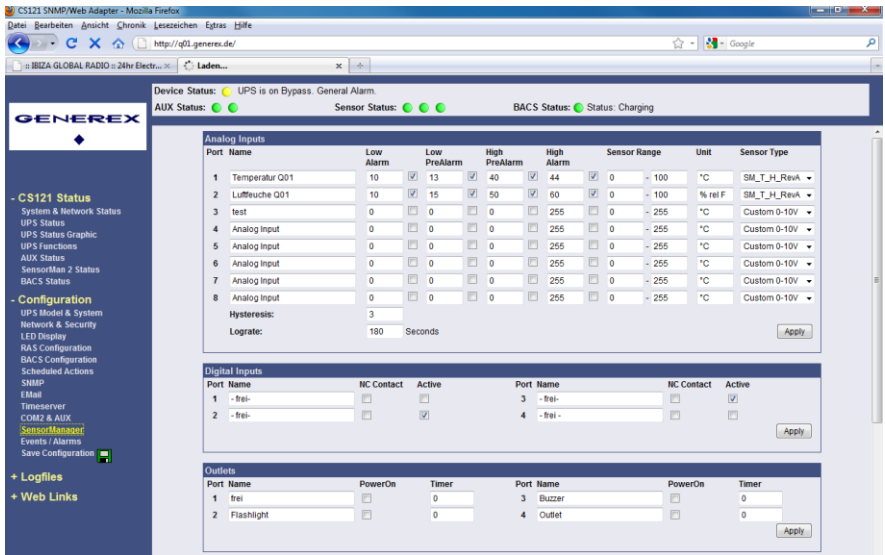

Figure 104: SENSORMANAGER II Settings

Using the splitting plugs (order number SPSMRJ) it is possible to connect up to 8 sensors and 4 contacts to the SENSOR-MANAGER. A MOUNTING KIT (sold separately) is available for affixing the SENSORMANAGER to walls and railings.

The power supply for the SENSORMANAGER may also supply an external CS121 using a SM-CS121 type cable (sold separately) by simply connecting the POWER OUT of the SENSORMANAGER with the POWER IN of the CS121 external.

Startup the SENSORMANAGER

Connect the sensors to the SENSORMANAGER. Connect the SENSORMANAGER using the Mini8-DBSub9 cable to the COM 2 port of the CS121. Finally, plug the power supply into one of the UPS power outlets. Check the LEDs on the bottom of the SENSORMANAGER; the right one should be flashing (reading request from CS121 COM2) and the left one should be constantly lit (power supply on). The flashing LED shows the requests from the CS121, the other LED shows that the device has started.



Figure 105: SENSORMANAGER II LEDs

Note: You have to configure the CS121 COM2 port to "SensorMan" (for SENSORMANAGER II "SensorMan 2") – otherwise the CS121 will not start making requests to the SENSOR MANAGER.

See the CS121 user manual for instructions on how to configure the CS121 for operation with the TEMPMAN/SENSOR MANAGER and how to manage and set the alarms.

The latest version of CS121 user manual is available for download at:

<http://www.generex.de/wwwfiles/dokus/1/cs121/german/pdf/cs121.pdf>

When the SENSOR MANAGER is running, you will see the values in the AUX section of the CS121 Web browser.

Detection of the analog temperature values via variables:

#TEMP1
#TEMP2
#TEMP3
#TEMP4
#TEMP5
#TEMP6
#TEMP7
#TEMP8

Pin layout of INPUT Socket the SENSORMANAGER Box:

INPUT 1:

Pin 1 Voltage 9-24Volt +
Pin 2 Analog Channel 1 (0-10V+)
Pin 3 Analog Channel 5 (0-10V+)
Pin 4 Ground
Pin 5 OUTPUT: Open collector OUT 9-24 V, max. 30mA
Pin 6 INPUT: Digital Input 9-24V

INPUT 2:

Pin 1 Voltage 9-24Volt +
Pin 2 Analog Channel 2 (0-10V+)
Pin 3 Analog Channel 6 (0-10V+)
Pin 4 Ground
Pin 5 OUTPUT: Open collector OUT 9-24 V, max. 30mA
Pin 6 INPUT: Digital Input 9-24V

INPUT 3:

Pin 1 Voltage 9-24Volt +
Pin 2 Analog Channel 3 (0-10V+)
Pin 3 Analog Channel 7 (0-10V+)
Pin 4 Ground
Pin 5 OUTPUT: Open collector OUT 9-24 V, max. 30mA
Pin 6 INPUT: Digital Input 9-24V

INPUT 4:

Pin 1 Voltage 9-24 Volt +
Pin 2 Analog Channel 4 (0-10V+)
Pin 3 Analog Channel 8 (0-10V+)
Pin 4 Ground

Pin 5 OUTPUT: Open collector OUT 9-24 V, max. 30mA

Pin 6 INPUT: Digital Input 9-24 V

Example:

Alarm INPUT contact

If the alarm contact INPUT is used, you may connect your alarm contact e.g. to INPUT 1 Pin 6 and Power supply Pin 1. In the CS121 you can configure that as a HIGH signal to the alarm is set – or the other way round.

OUTPUT contact

If you want to switch any relays or send high signals to the OUTPUT, you may connect your OUTPUT contact e.g. to INPUT 1 Pin 5 to your relays and configure the CS121 as “OUTPUT” for this signal. Now you may configure your Events in the CS121 to set the OUPUT to HIGH or LOW.

Sensor connection

The sensor has to work within 0-10Volts, this may be connected directly to Channels 1-8, and the CS121 will now show the values in its Web browser. Alarm thresholds and actions may be configured via the EVENT manager of the CS121.

7.3.3 Special features of theSENSORMANAGER II

Unlike the CS121 and the older SENSORMANAGER type, the new SENSORMANAGER II configuration data will be stored in the device itself on a non-volatile chip. This result in a different behaviour of the SENSORMANAGER II compared to the older SENSORMANAGER:

Acknowledged alarms are displayed in yellow in the status bar of the SENSORMANAGER II. Not confirmed alarms are displayed in red (at older SENSORMANAGER always in yellow).

After clicking the “Apply” button no rebooting is required, because the SENSORMANAGER II saves it configuration data in its internal ROM.

The 3 status diodes will be displayed in blue, if the communication between the CS121 and the SENSORMANAGER II is lost.

The status site of the SENSORMANAGER II was changed. The analog measurement values will be displayed vertical.



Figure 106: SENSORMANAGER II Status Site

7.3.4 Configuration

The SENSORMANAGER II provides the opportunity of the definition of pre-alarm-thresholds.

Beside the name of the input you also define here as shown above the alarm thresholds, the sensor range and the measurement unit. Note, that the alarm values (low and high) are only

active if the fields beside the alarm values are enabled. In the drop down menu "Sensor Type" some basic sensor models are already listed, which you can choose to set predefined values for these types (select "Custom" to make divergent or individual settings).

You can calibrate every sensor with the Sensor Range, that means if you want to rise a measured value for 5°C, just modify the default range from 0-100 to 5-100. Therefore you are able to adjust the measurement values like a gauged thermometer.

With the field "Hysteresis" you define the scope within the defined value can oscillate without releasing an alarm. This is important e.g. for temperature measurements, which are not increasing/decreasing continuously.

At "Lograte" you can set the loop time (in sec) in which the measured values will be written into the logfile.

Analog Inputs										
Port	Name	Low Alarm	Low PreAlarm	High PreAlarm	High Alarm	Sensor Range		Unit	Sensor Type	
1	Temperatur Rack	10	<input checked="" type="checkbox"/> 13	<input checked="" type="checkbox"/> 38	<input checked="" type="checkbox"/> 42	<input checked="" type="checkbox"/> 0	<input checked="" type="checkbox"/> - 100	*C	SM_II_T_H	
2	Luffeuchte Rack	15	<input checked="" type="checkbox"/> 17	<input checked="" type="checkbox"/> 45	<input checked="" type="checkbox"/> 47	<input checked="" type="checkbox"/> 0	<input checked="" type="checkbox"/> - 100	% rel F	SM_II_T_H	
3	Temperatur Serverraum	8	<input checked="" type="checkbox"/> 11	<input checked="" type="checkbox"/> 35	<input checked="" type="checkbox"/> 37	<input checked="" type="checkbox"/> 0	<input checked="" type="checkbox"/> - 100	*C	SM_II_T_H	
4	Luffeuchte Serverraum	12	<input checked="" type="checkbox"/> 15	<input checked="" type="checkbox"/> 42	<input checked="" type="checkbox"/> 45	<input checked="" type="checkbox"/> 0	<input checked="" type="checkbox"/> - 100	% rel F	SM_II_T_H	
5	Analog Input	0	<input type="checkbox"/> 0	<input type="checkbox"/> 0	<input type="checkbox"/> 100	<input type="checkbox"/> 0	<input type="checkbox"/> - 100	*C	Custom 0-10V	
6	Analog Input	0	<input type="checkbox"/> 0	<input type="checkbox"/> 0	<input type="checkbox"/> 100	<input type="checkbox"/> 0	<input type="checkbox"/> - 100	*C	Custom 0-10V	
7	Analog Input	0	<input type="checkbox"/> 0	<input type="checkbox"/> 0	<input type="checkbox"/> 100	<input type="checkbox"/> 0	<input type="checkbox"/> - 100	*C	Custom 0-10V	
8	Analog Input	0	<input type="checkbox"/> 0	<input type="checkbox"/> 0	<input type="checkbox"/> 100	<input type="checkbox"/> 0	<input type="checkbox"/> - 100	*C	Custom 0-10V	
Hysteresis:		3								
Lograte:		180	Seconds							

Figure 107: SENSORMANAGER II Configuration Analog Inputs

Outlets							
Port	Name	PowerOn	Timer	Port	Name	PowerOn	Timer
1	Outlet	<input type="checkbox"/>	5	5	Outlet	<input type="checkbox"/>	25
2	Outlet	<input type="checkbox"/>	10	6	Flashlight	<input type="checkbox"/>	30
3	Outlet	<input type="checkbox"/>	15	7	Outlet	<input type="checkbox"/>	35
4	Outlet	<input type="checkbox"/>	20	8	Outlet	<input type="checkbox"/>	40

Figure 108: SENSORMANAGER II Configuration Outlets

Furthermore it is possible to attach a timer value to each Outlet. This determines how long an outlet will be switched (in seconds). Set the timer value to "0" if the outlet is to be switched without any time limit.



Note: If you do not want to use a name for the Analog-, Digital Inputs or rather the Outlets, please set the following into the single name area:

7.3.5 Alarm Matrix of the SENSORMANAGER II

The following "Alarm Matrix" gives you numerous possibilities to configure dependencies between different alarm states and to logically combine them to different Event. This makes it possible to process an alarm scenario in dependency of the status of several input sensors. (For example: An alarm scenario is to be released only if two temperature sensors are out of range or if the air condition is not active. This requires to create a new event which gets "true" only if 2 or more other events are true)

Alarm Matrix																	
Marker Inverted	Logic	Digital Inputs								Analog Inputs							
		1	2	3	4	5	6	7	8	1	2	3	4	5	6	7	8
Marker 1	<input type="checkbox"/>	Or	<input type="checkbox"/>	<input type="checkbox"/>	<input type="checkbox"/>	<input type="checkbox"/>	<input type="checkbox"/>	<input type="checkbox"/>	<input type="checkbox"/>	<input checked="" type="checkbox"/>	<input checked="" type="checkbox"/>	<input type="checkbox"/>	<input type="checkbox"/>	<input type="checkbox"/>	<input type="checkbox"/>	<input type="checkbox"/>	<input type="checkbox"/>
Marker 2	<input type="checkbox"/>	And	<input type="checkbox"/>	<input checked="" type="checkbox"/>	<input type="checkbox"/>	<input type="checkbox"/>	<input type="checkbox"/>	<input type="checkbox"/>	<input type="checkbox"/>	<input type="checkbox"/>	<input checked="" type="checkbox"/>	<input type="checkbox"/>	<input type="checkbox"/>	<input type="checkbox"/>	<input type="checkbox"/>	<input type="checkbox"/>	<input type="checkbox"/>
Marker 3	<input type="checkbox"/>	And	<input type="checkbox"/>	<input type="checkbox"/>	<input type="checkbox"/>	<input type="checkbox"/>	<input type="checkbox"/>	<input type="checkbox"/>	<input type="checkbox"/>	<input type="checkbox"/>	<input type="checkbox"/>	<input type="checkbox"/>	<input type="checkbox"/>	<input type="checkbox"/>	<input type="checkbox"/>	<input type="checkbox"/>	<input type="checkbox"/>
Marker 4	<input type="checkbox"/>	And	<input type="checkbox"/>	<input type="checkbox"/>	<input type="checkbox"/>	<input type="checkbox"/>	<input type="checkbox"/>	<input type="checkbox"/>	<input type="checkbox"/>	<input type="checkbox"/>	<input type="checkbox"/>	<input type="checkbox"/>	<input type="checkbox"/>	<input type="checkbox"/>	<input type="checkbox"/>	<input type="checkbox"/>	<input type="checkbox"/>
Marker 5	<input type="checkbox"/>	And	<input type="checkbox"/>	<input type="checkbox"/>	<input type="checkbox"/>	<input type="checkbox"/>	<input type="checkbox"/>	<input type="checkbox"/>	<input type="checkbox"/>	<input type="checkbox"/>	<input type="checkbox"/>	<input type="checkbox"/>	<input type="checkbox"/>	<input type="checkbox"/>	<input type="checkbox"/>	<input type="checkbox"/>	<input type="checkbox"/>
Marker 6	<input type="checkbox"/>	And	<input type="checkbox"/>	<input type="checkbox"/>	<input type="checkbox"/>	<input type="checkbox"/>	<input type="checkbox"/>	<input type="checkbox"/>	<input type="checkbox"/>	<input type="checkbox"/>	<input type="checkbox"/>	<input type="checkbox"/>	<input type="checkbox"/>	<input type="checkbox"/>	<input type="checkbox"/>	<input type="checkbox"/>	<input type="checkbox"/>
Marker 7	<input type="checkbox"/>	And	<input type="checkbox"/>	<input type="checkbox"/>	<input type="checkbox"/>	<input type="checkbox"/>	<input type="checkbox"/>	<input type="checkbox"/>	<input type="checkbox"/>	<input type="checkbox"/>	<input type="checkbox"/>	<input type="checkbox"/>	<input type="checkbox"/>	<input type="checkbox"/>	<input type="checkbox"/>	<input type="checkbox"/>	<input type="checkbox"/>
Marker 8	<input type="checkbox"/>	And	<input type="checkbox"/>	<input type="checkbox"/>	<input type="checkbox"/>	<input type="checkbox"/>	<input type="checkbox"/>	<input type="checkbox"/>	<input type="checkbox"/>	<input type="checkbox"/>	<input type="checkbox"/>	<input type="checkbox"/>	<input type="checkbox"/>	<input type="checkbox"/>	<input type="checkbox"/>	<input type="checkbox"/>	<input type="checkbox"/>

Figure 109: Alarm matrix – Marker configuration

In the figure above is shown the alarm matrix with its 8 markers to be set or unset. Each marker thereby is a new state on which specific alarm scenarios can be released.

For example: In the figure above is configured that the Marker1 will be set, when at the analogue input 1 or 3 an alarm occurs. (Enabling the field “Marker Inverted” causes that Marker1 will be unset in case of an alarm at analogue input 1 or 3.) Furthermore marker 2 will be set, when at the digital input 2 and at the analogue input 2 an alarm state occurs at the same time. (Means that an alarm at just one input is not sufficient for setting marker 2) Accordingly it is possible to set (or unset) each marker in dependency of different digital and/or analogue input states.

After having defined the conditions when markers are to be set resp. unset, you can specify the actions to be executed when a marker will be set/unset. Therefore you have two possibilities: The first is to handle the actions through the event configuration, described later in chapter 3.2.5 Events / Alarms. This is possible because each marker has its own event “Alarm Marker x”, which can be configured through the event configuration.

The second possibility is to switch a relay output in dependency of the statue of one or several markers. Therefore you have the output matrix, figured as below. In this example is configured that Output 4 is to be switched on when Marker 1 or Marker 2 is set (or the opposite way around in case “Output Inverted” is enabled). Using the “Alarm Matrix” offers you numerous possibilities to switch Outputs in dependency of input alarms.

Output Inverted	Logic	Marker							
		1	2	3	4	5	6	7	8
Output 1	<input type="checkbox"/> And	<input type="checkbox"/>	<input type="checkbox"/>	<input type="checkbox"/>	<input type="checkbox"/>	<input type="checkbox"/>	<input type="checkbox"/>	<input type="checkbox"/>	<input type="checkbox"/>
Output 2	<input type="checkbox"/> And	<input type="checkbox"/>	<input type="checkbox"/>	<input type="checkbox"/>	<input type="checkbox"/>	<input type="checkbox"/>	<input type="checkbox"/>	<input type="checkbox"/>	<input type="checkbox"/>
Output 3	<input type="checkbox"/> And	<input type="checkbox"/>	<input type="checkbox"/>	<input type="checkbox"/>	<input type="checkbox"/>	<input type="checkbox"/>	<input type="checkbox"/>	<input type="checkbox"/>	<input type="checkbox"/>
Output 4	<input type="checkbox"/> Or	<input checked="" type="checkbox"/>	<input checked="" type="checkbox"/>	<input type="checkbox"/>	<input type="checkbox"/>	<input type="checkbox"/>	<input type="checkbox"/>	<input type="checkbox"/>	<input type="checkbox"/>

Disable Outputs:

Apply

SensorManager II Version: 2.01

Figure 110: Alarm Matrix – Switching of relay outputs

Outlets			Outlets		
Status	Switch	Name	Status	Switch	Name
1	<input type="radio"/> Switch On	Outlet 1	5	<input checked="" type="radio"/> Switch Off	Outlet 5
2	<input type="radio"/> Switch On	Outlet 2	6	<input type="radio"/> Switch On	Outlet 6
3	<input type="radio"/> Switch On	Outlet 3	7	<input checked="" type="radio"/> set by marker	Outlet 7
4	<input type="radio"/> Switch On	Outlet 4	8	<input checked="" type="radio"/> set by marker	Outlet 8

Figure 111: Alarm Matrix – Switching of relay outputs

Detection of the analog temperature values via variables:

```
#SM2_ANALOG0
#SM2_ANALOG1
#SM2_ANALOG2
#SM2_ANALOG3
#SM2_ANALOG4
#SM2_ANALOG5
#SM2_ANALOG6
#SM2_ANALOG7
```

7.4 RASMANAGER

The RAS-Manager relays alarm signals coming from monitoring devices such as UPS, SiteManagers, contact alarms and the like to monitoring stations or email receivers. Any computer with RAS capabilities (Windows, Linux) can be used as a monitoring station. The only requirement is the setup of an PPPServer on the monitoring station. After the establishment of communications between the RAS-Manager and the monitoring station, a RCCMD signal is sent that depending on configuration can either make log entries, send emails and SMSs or execute programs.

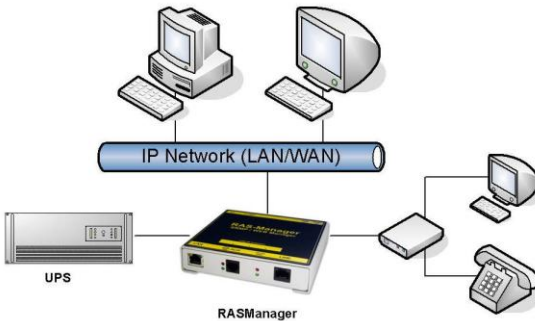

Figure 112: RASMANAGER network integration

7.5 GSM Modem – Notification via SMS

The CS121 firmware version 4.17.x provides a new function, which enables the notification via SMS. Use the CS121 configuration cable (not included) and an adapter-connector (PINs 2, 3, 5, GENEREX order number: GSM_A) for the connection of the GSM modem and the CS121. Select into the menu “COM2 & AUX” the GSM Modem” for the COM2 mode.



Note: It is required to disable the PIN-code request of the SIM-card.

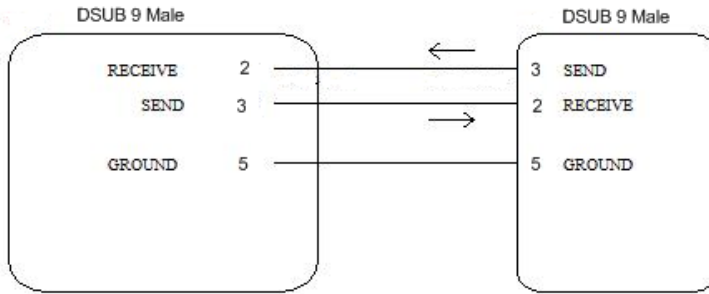

Figure 113: PIN Adjustment Adapter-Connector GSM_A

Alternative, you can make a Mini8-DSUB9 cable for the Siemens GSM TMA T35i Modem by yourself, as follows:

Cable from CS121/COM2 to SiemensTC35i-Modem

Pin COM2
Mini-DIN 8 pol male\ CS121

SUB-D 9 male connector
SPI 3

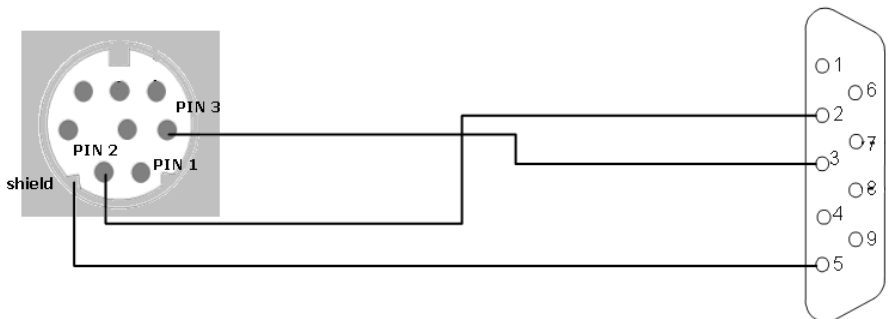

Figure 114: Mini8-DSUB9 Cable Cross-Section

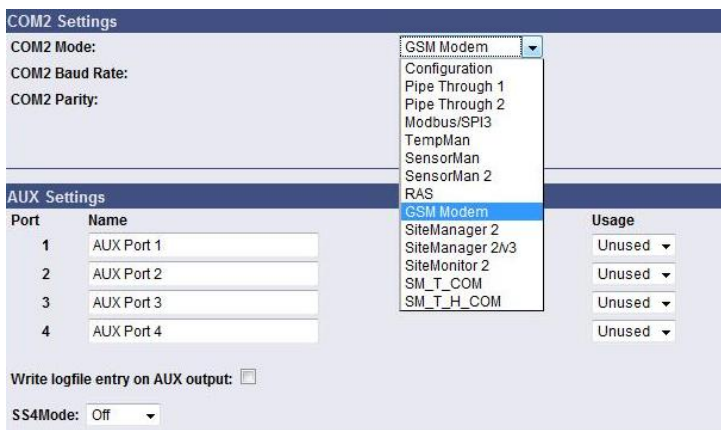

Figure 115: COM2 Mode: GSM Modem

Add an accordant function via the “Events / Alarms” menu. Select the function “Send SMS with GSM modem” for the notification via SMS and set the telephone number of the receiver and the message.

Powerfail' Job 3	
Function:	Send SMS with GSM modem
Phone Number:	040226929117
Message:	Stromausfall USV 1!
This job will only be executed if COM2 mode is set to 'GSM Modem'	

Figure 116: Configuration of the Function



Attention: Do not use special character in the messages! If you want to send a SMS to several receivers, it is required, that you define a SMS job for every receiver.

LED Status Display

Operating Status:	LED Signaling:
SIM card not present	Slowly red flashing
SIM card active	Fast red flashing



Figure 117: Siemens GSM TMA T35i Modem

Into the menu “System & Network Status” you can see the signal level of the modem, to adjust your antenna optimal. Green means a good signal is present.

System Info & Network Status			
System Information			
CS121 Hardware	CS131	Location	
CS121 Firmware	CS121-SNMP v.4.17.12.090831	System Name	CS-121
	HyNeoOS Rel. 2.4.1.32(pdsu) - Aug 27, 2009 TTarget Server Rel. 2.4.1.15(pdsu) - Aug 08, 2009 DRIVER Genetex CS123 Rel. 2.4.1.79(pdsu) - Aug 29, 2008 Loader: B0JCS123, ROM-Version: 2.3.131(pdsu) - Jun 05, 2009 UPS driver: 714	System Contact	
UPS Manufacturer	Genetex	Attached Devices	UPS protected devices
UPS Model	smart offline UPS	System Time	02.09.2009 12:17:07
		Uptime	0 days 0 hours 10 minutes 3 seconds
		Total Uptime	Approx. 0 days 0.2 hours
		GSM Signal Quality	-109...-53 dBm
Network Status			
MAC Address	00-03-05-0E-07-19	Telnet Server	On
Network Speed	AUTO	HTTP Server	On
IP Address	192.168.222.186	Upsimon Server	On
Subnet Mask	255.255.255.0	Use RCCMD2 Traps	Yes
Default Gateway	192.168.222.100	SNMP Server	On
DNS Server	192.168.222.100	Use SNMP Coldboot Trap	No
EEmail Server	not configured	Use SNMP Authentication Trap	No
Time Server	129.6.15.29	Modbus Server	On

Figure 118: GSM Signal Quality Display

7.6 LED-Matrix Display

The LED-Matrix display is a remote display unit for relaying RCCMD messages that can be operated via the Ethernet.

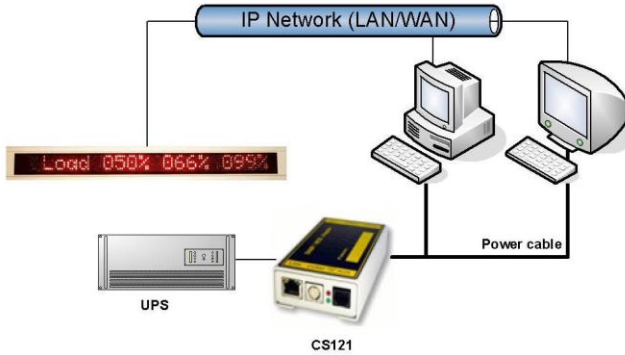

Figure 119: LED-Matrix display network integration

Any device operating as an RCCMD Sender like a computer running UPSMAN software, RCCMD clients, CS121 Web managers and other RCCMD 2 compatible products can send text messages or environmental data values to the LED-Matrix and can add sounding alarms for warnings that require immediate attention. Users can also use the built in Web server interface of the LED-Matrix to relay alarms and messages without the use of an RCCMD Sender. The user simply enters the message into the Web browser that is to be relayed through the LED-Matrix.

For further information and description please take a look into the **LED-Matrix User Manual**.

7.7 MODBUS/PROFIBUS/LONBUS

• MODBUS

Modbus is a serial communications protocol for use with its programmable logic controllers (PLCs). It has become a de facto standard communications protocol in industry, and is now the most commonly available means of connecting industrial electronic devices. Modbus allows for communication between many devices connected to the same network, for example a system that measures temperature and humidity and communicates the results to a computer. Modbus is often used to connect a supervisory computer with a remote terminal unit (RTU) in supervisory control and data acquisition (SCADA) systems.

The CS121-series (exclude BUDGET models) support MODBUS over IP and MODBUS over RS232 generally. Additionally, the CS121MODBUS-series also includes an RS485 interface at COM2, which can be connected to a 485Bus-system.



Note: MODBUS response changed: Now MODBUS will respond with "-9999" or with "-1", if values are requested, which are not available at this UPS or other device. This shall clearly identify that this value is "not available".



Note: If you use SNMP polling to retrieve data from the CS121, you should disable the MODBUS port to avoid interrupts and performance slow down.

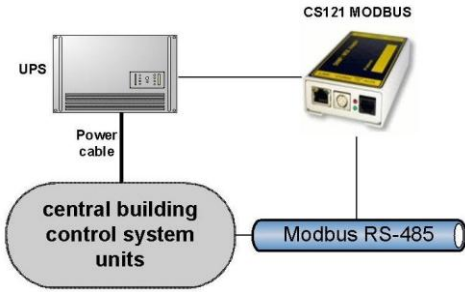

Figure 120: CS121MODBUS Installation

- PROFIBUS, LONBUS and other Field busses

PROFIBUS (**Process Field Bus**) is the most popular type of fieldbus with more than 14 million nodes (2006) in use worldwide. PROFIBUS was defined in 1991/1993 as DIN 19245, moved in 1996 to EN 50170 and is since 1999 included in IEC 61158/IEC 61784 Standards.

To integrate the CS121 in a Profibus environment, GENEREX offers a Profibus gateway, which converts the MODBUS output of the CS121 into PROFIBUS environment. The implementation of LONBUS or any other GENEREX field bus converter takes place in similar way.

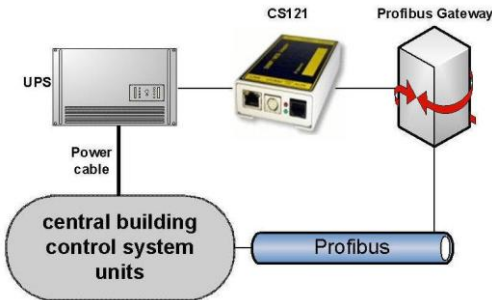
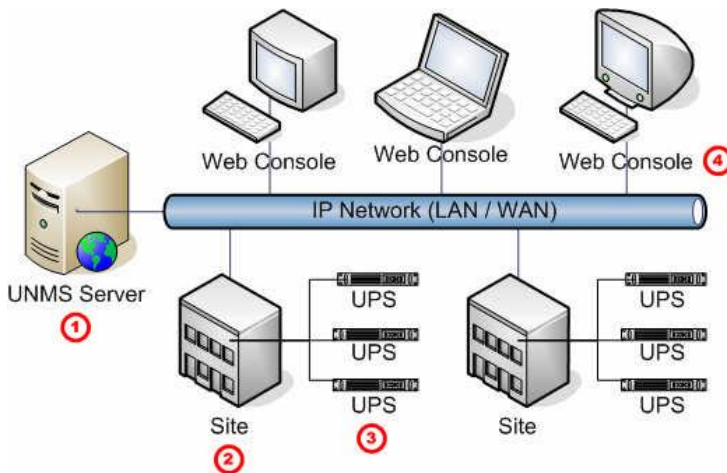

Figure 121: CS121 PROFIBUS Installation

7.8 UNMS (UPS-Network Management System)

UNMS II is a UPS network monitor designed to inform you of emergency power supply systems problems before your clients, end-users or managers do. The UNMS as a limited version is part of every UPSMAN license (UPSMAN suite contains UPSMAN RS232/USB UPS Manager, UPSMON Windows client and UNMS 2 – limited to 9 UPS). The UNMS Server Service runs intermittent checks on UPS devices you specify. When problems are encountered, the UNMS Server Service can send notifications out to administrative contacts in a variety of different ways (For example: Email). Current status information, historical logs, and reports can all be accessed via a web browser (Web Console).



No.	Name	Description
①	UNMS Server	The UNMS Server Service and the related Web-Server installation.
②	Site	A user defined group of services (For example: UPS devices).
③	UPS	A single service (e.g. UPS device) that is monitored by the UNMS Server.
④	Web Console	Web-Consoles provide sharing of management information by many people.

Figure 122: UNMS-Installation

7.9 SNMP

The CS121 can be monitored via web-browser, UPSView, MODBUS, PROFIBUS, LONBUS, Email and SNMP (e. g. NAGIOS). The RFC1628cs121 SNMP MIB is at present. The installation and setup of a SNMP browser is described into the Appendix.

MIB-Integration into your NMS

Standard-NMS Installations require for each device to be monitored its specific MIB (Management Information Base). To monitor the CS121 the Standard-MIB for UPS-systems, RFC1628, is generally to be integrated into your NMS.

To identify CS121 adapters in your network you may use the MAC address. The MAC address of every CS121 adapter starts with 00-03-05-02-XX-XX, whereas this address can be found in the Telnet menu (menu: IP address, gateway address, MIB system group).

Your SNMP adapter is now installed and fully functional. Please read the following for configuration and functionality descriptions of the adapter.

The MIB is to be loaded onto each SNMP Management Station that is monitoring an UPS via an UPS SNMP Agent. The MIB determines which UPS parameters can be monitored and controlled with the SNMP commands „get“ and „set“.

To complete the SNMP adapter installation and configuration process, you must compile the necessary MIBs to configure the NMS. Any NMS with a MIB compiler can manage the SNMP adapter.

Perform a „get“ and a „set“. If the get or set command fail, check the SNMP adapter access control. The manager must have read permission to execute a get command and read / write permission to execute a set command successfully.

For instructions on how to compile MIBs for the most popular NMSs - Novell's NetWare Management Station, Hewlett-Packard's OpenView Network Node Manager, and SunConnect; SunNet Manager; see the corresponding heading below.

Please note that the CS121 uses the standard MIB, which is included in most SNMP software already. This MIB is called UPSMIB and corresponds with the Standard RFC1628. In most cases compiling of the MIB is not required as it can be found under:

iso.org.dod.internet.mgmt.mib2.upsMIB

Please check your MIB directory before compiling the RFC1628!

Configure the NMS

- Set/compile the device MIB, if there is no standard UPS MIB RFC 1628 (CS121 only!)
- Add the SNMP adapter object to the management map and configuration of the events (e.g. message to the operator)
- Ping the SNMP adapter

Due to the different compilation procedures of the SNMP software products, it is not possible to explain the general procedures in greater detail. The compilation of a MIB file is explained in the general SNMP software manuals. Please contact the support, if you cannot resolve errors using this manual.

After the compilation the UPS software can be polled via a MIB browser and data can be read. Please choose the corresponding MIB variable or string of MIB variable and set the destination address TCP/IP of the adapter. The adapter will answer with the UPS data.

Alternatively the Windows UPSMON, JAVAMON or the UPS SNMP WATCH of the DataWatch Pro Software can be used. The UPS data will then be displayed graphically and internal UPS information, which are only useful to the technical support, will be hidden. In addition to this, the UPS SNMP WATCH is able to manage groups of UPS devices, in order to manage parallel redundant UPS systems.

As an optional add-on for the HP OpenView software, a snap-in may be ordered for UPSMAN/CS121.



Note: SNMP response changed: Now only those SNMP requests are answered, which are present at this UPS or other device. Missing data does no longer cause a return value "0" or "-1". An SNMP Walk will now no longer return any OIDs, which are not supported by this UPS.

8. Troubleshooting – FAQ

8.1 Solutions

Problem 1: Timeserver not at present

Solution 1: Configure a workstation as timeserver

- Microsoft Windows SNTP Timeserver: As timeserver you can use any e.g. Windows PC in your network which has access to a timeserver in the internet or a local PC clock. To use the Microsoft Windows timeserver you have to configure and start the "Windows Time Server" service – see screenshot in the service list:

The screenshot shows the Windows Services console window titled 'Dienste'. The 'Dienste (Lokal)' tab is active, displaying a list of services. The 'Windows-Zeitgeber' service is highlighted in blue. The service is currently 'Gestartet' (Started) and has an 'Automatisch' (Automatic) startup type. The description for this service is 'Verwaltet die Datum- und Uhrzeitsync...'.

Name	Beschreibung	Status	Autostarttyp	Anmelden als
WWW-Publishing	Stellt Webverbindung und Webverwal...	Gestartet	Automatisch	Lokales System
WMI-Leistungsadapter	Bietet Leistungsbibliotheksinformation...	Gestartet	Manuell	Lokales System
Windows-Zeitgeber	Verwaltet die Datum- und Uhrzeitsync...	Gestartet	Automatisch	Lokales System
Windows-Verwaltungs...	Bietet eine standardmäßige Schnittste...	Gestartet	Automatisch	Lokales System
Windows-Firewall/Gemei...	Bietet allen Computern in Heim- und Kl...	Gestartet	Automatisch	Lokales System
Windows-Bilderfassung ...	Bietet Bilderfassungsdienste für Scan...	Gestartet	Manuell	Lokales System
Windows-Installer	Print-Anwenschriften, die als ein Wind...	Gestartet	Manuell	Lokales System

Figure 123: MS-Timeservices

To turn your Windows computer into a timeserver, double-click on the clock in the lower right taskbar and open the following example. After some seconds the tab “Internet Time” appears. Click on “Internet Time” and check if the timeserver you have chosen here works correctly.

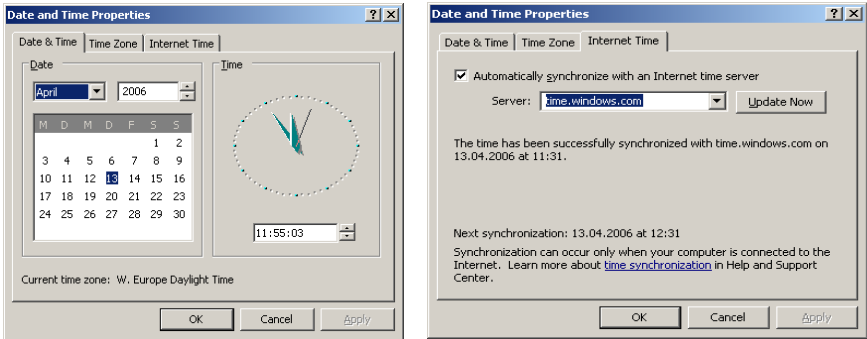

After having configured and started your Microsoft Windows Timeserver you have to reboot your computer and check the Event Logfile of Windows to ensure, the service was started correctly. In this case, you can configure your CS121 Timeserver using the IP-address of this Windows computer.



Note: Please check if your computer is reachable through the network. You may have to change the Windows Firewall settings to allow inbound/Outbound UDP port 123.

At Windows Server 2003 and 2008 it is required to enable the NTP server into the registry manually. Open the following folder:

HKEY_LOCAL_MACHINE\SYSTEM\CurrentControlSet\Services\W32Time\TimeProviders\NtpServer

Click with the right mouse button onto “Enabled” and change the “Value Data” from 0 to 1. After this change stop/start the W32 Time service.

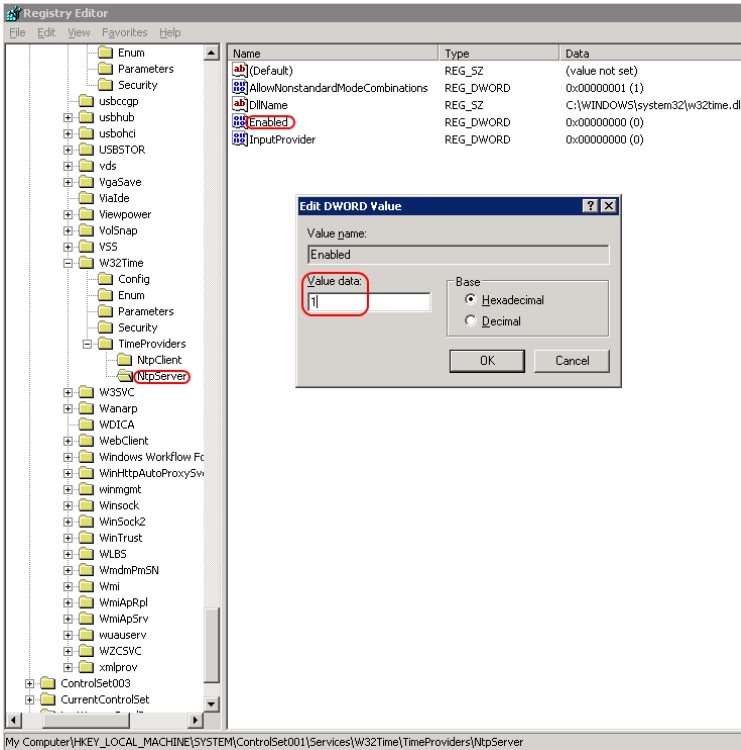

Figure 124: Registry NTP Server

NTP Time Synchronisation (UNIX)

The Network Time Protocol is defined in RFC1305 and provides the transfer and the maintenance of the time functions via distributed network systems.

Basic Configuration

The following command executes the synchronization of the local system to another server, to get the most accurate time, prior of the start of the NTP server configuration.

```
[bash] #ntpd -b
```

If this command does not work, please use the following:

```
[bash] #ntp -b
```

```

root : bash
File Edit View Scrollback Bookmarks Settings Help
Linux-f36j:~ # ifconfig
eth2      Link encap:Ethernet  Haddr 00:0C:29:57:EC:55
          inet addr:192.168.200.60  Bcast:192.168.200.255  Mask:255.255.255.0
          inet6 addr: fe80::20c:29ff:fe57:ec55/64  Scope:Link
          UP BROADCAST RUNNING MULTICAST  MTU:1500  Metric:1
          RX packets:594 errors:0 dropped:0 overruns:0 frame:0
          TX packets:441 errors:0 dropped:0 overruns:0 carrier:0
          collisions:0 txqueuelen:1000
          RX bytes:244373 (238.6 Kb)  TX bytes:50308 (49.1 Kb)
          Interrupt:19 Base address:0x2024

lo        Link encap:Local Loopback
          inet addr:127.0.0.1  Mask:255.0.0.0
          inet6 addr: ::1/128  Scope:Host
          UP LOOPBACK RUNNING  MTU:16436  Metric:1
          RX packets:70 errors:0 dropped:0 overruns:0 frame:0
          TX packets:70 errors:0 dropped:0 overruns:0 carrier:0
          collisions:0 txqueuelen:0
          RX bytes:4364 (4.2 Kb)  TX bytes:4364 (4.2 Kb)

Linux-f36j:~ # ntpd -b
Linux-f36j:~ # █

```

Figure 125: *Bash ntpd -b*

Create a backup of the original file (/etc/ntp.conf) :

```
[bash]#cp /etc/ntp.conf /etc/ntp.conf.original
```

Edit the configuration as follows:

```
[bash]#vi /etc/ntp.conf
```

The following information are required into the /etc/ntp.conf file :

```

#Finding a Time Source.
# The default configuration for ntpd servers after version 4.2 uses the NTP #Pool for
the default server sources.
Server 0.pool.ntp.org
server 1.pool.ntp.org
server 2.pool.ntp.org
# Access Controls.
restrict default kod nomodify notrap noquery nopeer
#The NTP Pool servers have been listed as a time source already (ver 4.2
#onwards), and they too need restrictions applied so the local server can
#synchronise from them. Ensure the access control parameters are strict #enough
that the remote servers can only be used for queries.
restrict 0.pool.ntp.org mask 255.255.255.255 nomodify notrap
noquery
restrict 1.pool.ntp.org mask 255.255.255.255 nomodify notrap
noquery
restrict 2.pool.ntp.org mask 255.255.255.255 nomodify notrap
noquery
# To allow all the workstations inside the internal private network to be able to query
the #time from your server, use the following access control rule (adjust subnet if
needed).
restrict 192.168.1.0 mask 255.255.255.0 nomodify notrap

```

```
server          127.127.1.0      # local clock
fudge           127.127.1.0 stratum 10
driftfile       /var/lib/ntp/drift
broadcastdelay  0.008
keys            /etc/ntp/keys
```

Start of the NTP

```
[bash]#ntpd -b
```

If this command does not work, use the following:

```
[bash]#ntp -b
```



```
root : bash
File Edit View Scrollback
Linux-f36j:~ # ntpd -b
Linux-f36j:~ # ntp -b
bash: ntp: command not found
Linux-f36j:~ #
```

Figure 126: Bash ntp -b

You should now set the runlevels, which are required for the NTPD service:

```
chkconfig --level 2345 ntpd on
/etc/init.d/ntpd restart
```

or

```
chkconfig --level 2345 ntp on
/etc/init.d/ntp restart
```



```
root : bash
File Edit View Scrollback Bookmarks
Linux-f36j:~ # ntpd -b
Linux-f36j:~ # ntp -b
bash: ntp: command not found
Linux-f36j:~ # chkconfig --level 2345 ntpd on
ntpd: unknown service
Linux-f36j:~ # chkconfig --level 2345 ntp on
Linux-f36j:~ #
```

Figure 127: Runlevel

You can check with the following command, which runlevels are active::

```
[bash]# chkconfig --list ntpd
```

or

```
[bash]# chkconfig --list ntp
```

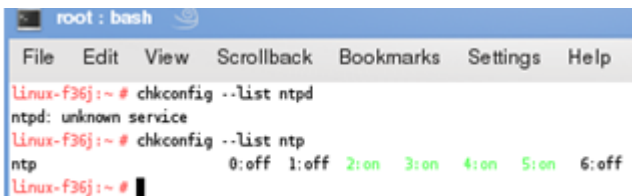

```
root : bash
File Edit View Scrollback Bookmarks Settings Help
Linux-f36j:~ # chkconfig --list ntpd
ntpd: unknown service
Linux-f36j:~ # chkconfig --list ntp
ntp          0:off 1:off 2:on 3:on 4:on 5:on 6:off
Linux-f36j:~ #
```

Figure 128: Check Configuration

Execute the following command, to check, if the service is started successful:

```
[bash]# grep ntpd /var/log/messages
```

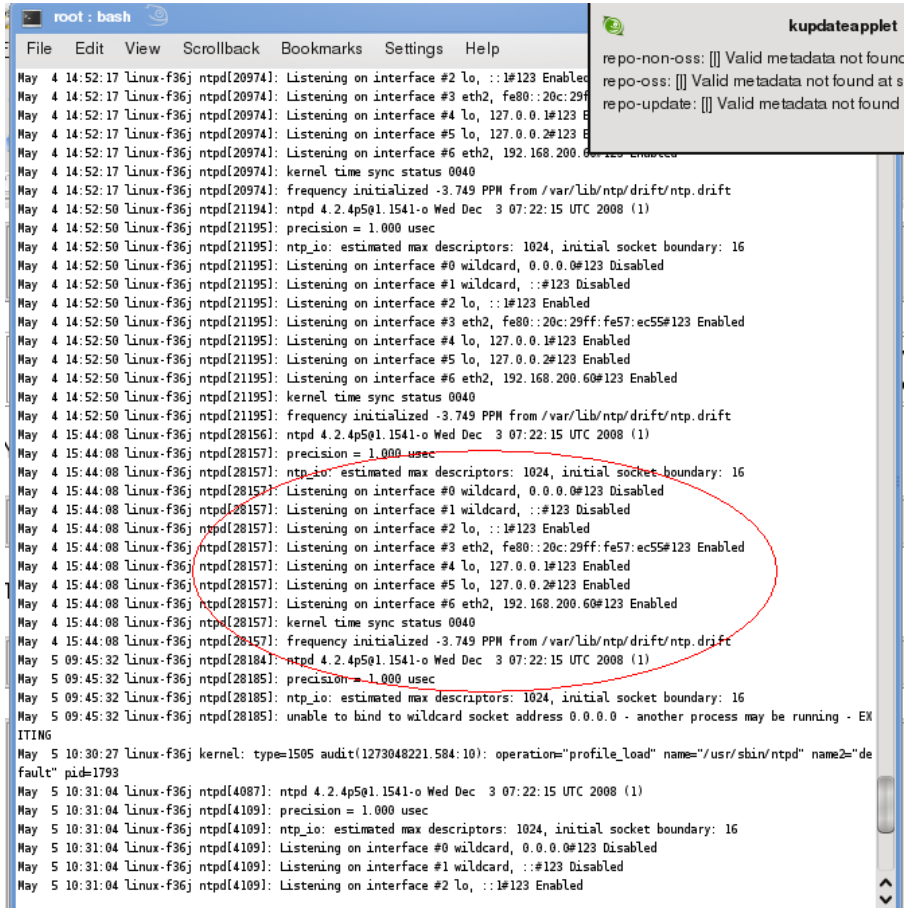

The screenshot shows a terminal window with the command `grep ntpd /var/log/messages` executed. The output displays the startup sequence of the NTP daemon (ntpd) across several time intervals. Key events include: listening on various network interfaces (eth2, eth3, eth4, eth5, eth6, wilddcard, #123), initializing the frequency to -3.749 PPM, setting precision to 1.000 usec, and estimating the maximum number of descriptors to 1024. A red circle highlights the section where ntpd starts on interface #2 (lo) at 15:44:08. A grey tooltip is visible in the upper right corner of the terminal window, containing the text: `repo-non-oss: [] Valid metadata not found`, `repo-oss: [] Valid metadata not found at s`, and `repo-update: [] Valid metadata not found`.

Figure 129: Check Configuration

Use the NTP Query Tool:

```
bash]# ntpq -pn
```

```

root : bash
File Edit View Scrollback Bookmarks Settings Help
Linux-F36j:~ #
Linux-F36j:~ #
Linux-F36j:~ #
Linux-F36j:~ #
Linux-F36j:~ #
Linux-F36j:~ #
Linux-F36j:~ #
Linux-F36j:~ #
Linux-F36j:~ # clear
Linux-F36j:~ # ntpq -pn
Linux-F36j:~ #

```

remote	refid	st	t	when	poll	reach	delay	offset	jitter
127.127.1.0	.LOCL.	5	l	51	64	377	0.000	0.000	0.001
+85.214.116.15	192.53.103.108	2	u	63	256	377	27.006	-9.076	1.490
*188.193.210.74	.DCFi.	1	u	190	256	377	62.568	-9.612	2.250
+89.238.71.130	192.53.103.108	2	u	182	256	377	21.031	-1.951	2.113
127.127.1.0	.LOCL.	10	l	27	64	377	0.000	0.000	0.001

```

Linux-F36j:~ # █

```

Figure 130: NTP Query

Problem 2: Inform Pyramid DSP Series Communication with UPS Slotcard inside does not start the UPS communication or if the external RS232 communication does not work.

Solution 2: It is required to put the DIP switches onto the UPS mainboard into the position "ON", if you are using a CS121 SNMP slot card! Put the DIP switches into the position "OFF", if you are using an external CS121 via RS232 interface!

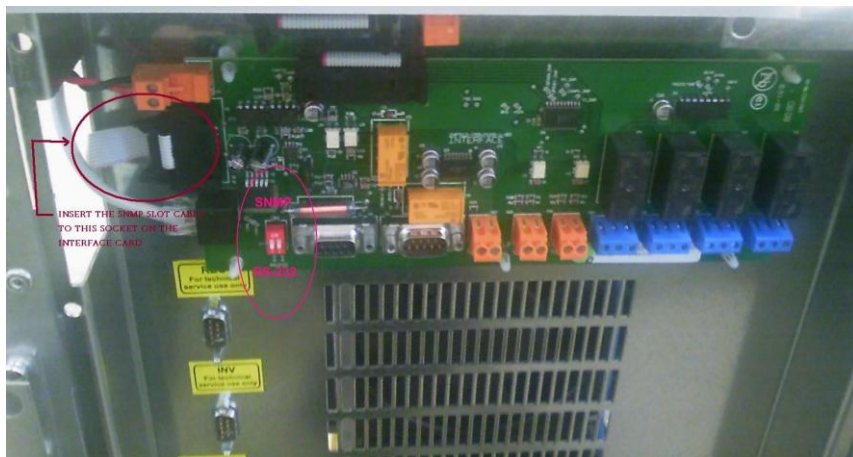

Figure 131: Mainboard Inform Pyramid DSP

Problem 3: CS121 reboots again and again after a few time into company's network environment.

Solution 3: The network monitoring software "WhatsUp Gold" is started. We do not support this software, stop the service, problem solved.

Problem 4: Sending of RCCMD signals, the following error is logged into the CS121 AlarmLog:

```

03/15/2011,14:13:39, RCCMD is connecting to 192.168.10.57:6003 (RccmdConn01)
03/15/2011,14:13:39, RCCMD could not connect. (RccmdConn01) Reason: ProtMan connect: out of ressources (no more src ports)
03/15/2011,14:19:18, RCCMD is connecting to 192.168.10.80:6003 (RccmdConn01)
03/15/2011,14:19:18, RCCMD could not connect. (RccmdConn01) Reason: ProtMan connect: out of ressources (no more src ports)

```

Figure 132: CS121 AlarmLog, ProtMan Connection

Solution 4: The CS121 has no more free ports to execute the task. Restarting the CS121 is a temporary solution. If you still have a device with 4MB in use, you should consider a hardware upgrade to the present hardware generation.

Problem 5: No communication possible to APC UPS SURTD from 2011

Solution 5: This UPS model communicates with a proprietary protocol. It is required to use the APC slot card Legacy (AP9620) for the establishment of a communication.

Problem 6: Got my CS121 an AUX interface or a COM3 interface?

Solution 6: AUX and COM3 reside into the same RJ10 port. The COM3 is used for the BACS only.

Problem 7: While sending Email you see the following error message: :

05/20/2014,08:59:59, MAIL: bad answer from mail server: 504 5.7.4 Unrecognized authentication type.

Solution 7: The setting for mail encryption has to match the configuration on your mail-server.

Problem 8: Not all modules are transferred to the slave into Pipe Through modus.

Solution 8: Since firmware version 5.x it is required, that you wait at least 20 minutes, until the master got all required information from all modules. Then restart the slave and all modules will be transferred correctly.

Problem 13: The following error message displays when opening the web-Interface:

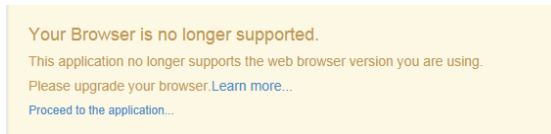

Figure 133: Error – Browser is no longer supported

Solution 13: Should you use the Internet Explorer version 8 or higher and see this message, a configured proxy server ist the reason. In the IE internet options you will find the LAN-settings menu in the Connection tab,. Activate the function ‚Bypass proxy servers for local addresses‘ will fix this issue.



Figure 134: Internet Explorer LAN Proxy Einstellungen

Appendix

A. CS121 - Technical data

Product	Power	Size	Weight	Operating temperature
CS121L (Extern)	12VDC 300 mA.	12,5 x 7 x 2,8 cm	210 gr.	< 40° C
CS121SC (Slot chinese)		13,5 x 6 x 1,5 cm	66 gr.	< 40° C
CS121F (Slot FUJI)		7,5 x 8 x 1,5 cm	64 gr.	< 40° C
CS121R (Slot RIELLO)		14,5 x 7,5 x 1,5 cm	80 gr.	< 40° C
CS121MOD (MODBUS Extern)		12,5 x 7 x 2,8 cm	210 gr.	< 40° C
CS121BL (Budget Extern)	12VDC 300mA.	12,5 x 7 x 2,8 cm	202 gr.	< 40° C
CS121BSC (Budget Slot Chinese)		12,5 x 7 x 2,8 cm	59 gr.	< 40° C

	CS121-L	CS121-C	CS121 Slot
Power supply	12 V DC	12 V DC	12 V DC
Power output	350mA	100mA bei 12V	100mA bei 12V
Size	69x126 mm	69x126 mm	60x120 mm
Ethernet connections	10/ 100Base-T	10/ 100Base-T	10/ 100Base-T
RS-232 interface	2	2	2
LED's	4	4	4
DIP Switches	2	2	2
Operating temperature	0 – 40 °C	0 – 40 °C	0 – 40 °C
Humidity during normal operations	10-80%, no condensation		

B. CE- and UL-Certification

Both models, CS121L and CS121SC, are certificated by Underwriters Laboratories Inc. for the US and Canada with the power supply 12 V DC, 300 mA.

As well, for both hardware specifications 121 and 131 of CS121-Adapter a certification of Conformity has been drawn up. Please see the download page at www.generex.de to get a copy of the certifications and documents.

C. Cable and Circuit board configuration, Pin/AUX-Ports, SensorMan

CS121 Config cable

without Handshake

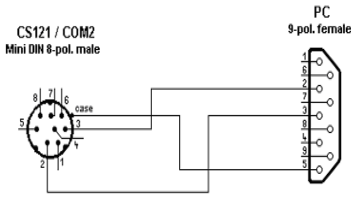

Figure 135: Cable configuration HW121 COM2

CS121 HW121/HW131 configuration cable with handshake

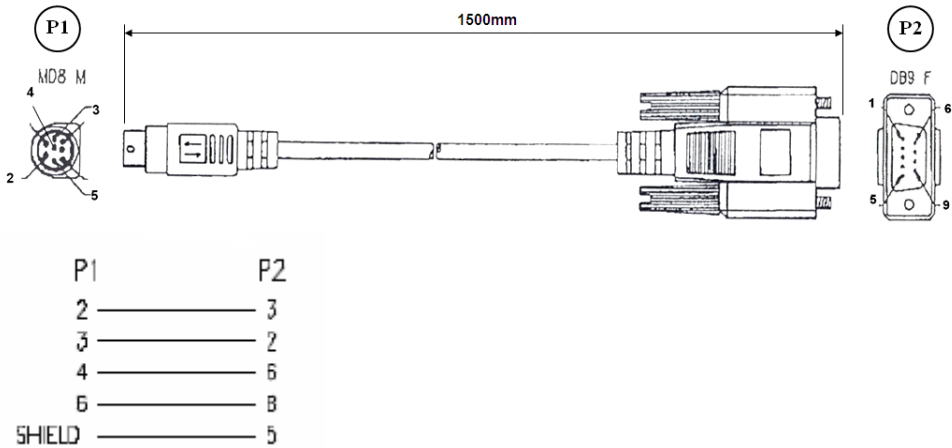

Figure 136: Cable configuration HW121/HW131 COM2

Pin Layout CS121 COM1:

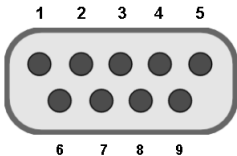

Figure 137: External D-SUB 9-polig male

- | | |
|-----------|-----------|
| Pin1: DCD | Pin6: DSR |
| Pin2: RxD | Pin7: RTS |
| Pin3: TxD | Pin8: CTS |
| Pin4: DTR | Pin9: RI |
| Pin5: GND | |

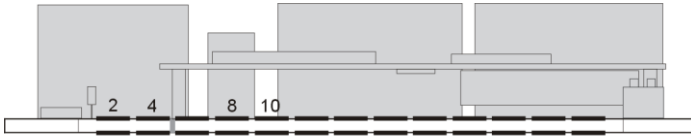

Figure 138: Slot version: Circuit board connection

- Pin1: -> GND
- Pin2: -> VDD
- Pin3: -> TxD
- Pin4: -> RxD
- Pin9: -> GND
- Pin8 connected with Pin 10

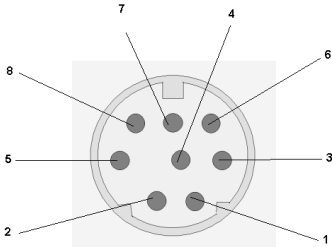

Figure 139: Pin COM2 Mini-DIN 8 pol female

Mini DIN 8 socket RS-232:

- Pin1: -> DCD
- Pin2: -> RxD
- Pin3: -> TxD
- Pin4: -> DTR
- Pin5: -> DSR
- Pin6: -> RTS
- Pin7: -> CTS
- Pin8: -> RI
- Schirm -> GND

RS-485 (optional):

- Pin1: -> RS485/B(+)
- Pin5: -> RS485/A(-)

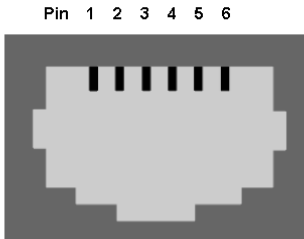

Figure 140: AUX-Port (Hardware Revision 1.1 = from Serial numbers 0121-1203, 0122-00198, 0123-00564 onwards) RJ11 6-pol

- Pin1: -> +3,3V
- Pin2: -> Input/Output 1
- Pin3: -> Input/Output 2
- Pin4: -> Input/Output 3
- Pin5: -> Input/Output 4
- Pin6: -> GND

The maximum input voltage is 3,3V. The input signals may be fed from external power sources or feed directly from Pin 1. If the external power supply delivers more than 3,3V a pre-resistor has to be fitted. The input resistance of the input is 1,5 k Ω

When using a opto coupler switch, a Pull up resistor of 1,5kOhm has to be used.

Output-voltage: If configured as OUTPUT, every Pin delivers 3.3 Volt/10mA.

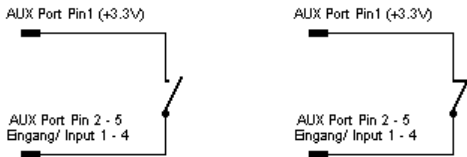

Figure 141: Example (Inputs): Opener or closer contact (only on hardware model CS12 1)

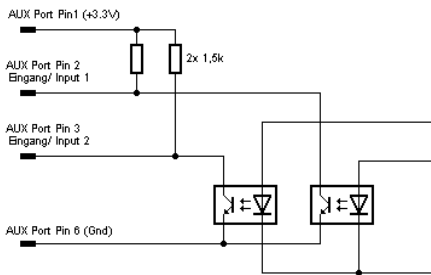

Figure 142: Opto coupler logic

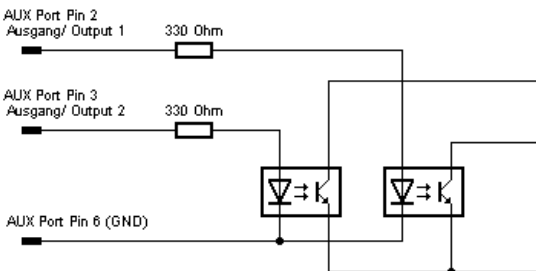

Figure 143: Example (Outputs)

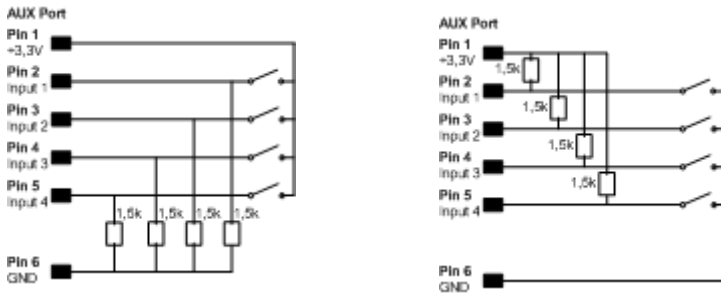

Figure 144: Examples: AUX Input on hardware model CS131 only, left side “pull-down”, right side “pull-up” configuration

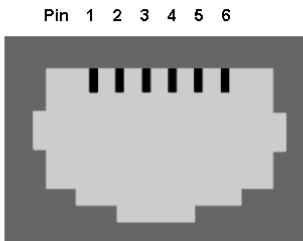

Figure 145: AUX Port Assignment

AUX port assignment for CS121 HW131 L from serial number 0121-10417 and CS121 HW131 SC from serial number 0123-09428:

- PIN 1: 3,3V
- PIN 2: AUX port 0: disposable
- PIN 3: AUX port 1: disposable
- PIN 4: AUX port 2: RX from COM3 (input)
- PIN 5: AUX port 3: TX from COM3 (output)
- PIN 6: GND

D. CS121 WDP – Watchdog & Powermanager

The CS121 WDP is an optional Watchdog & Powermanager piggyback board for the CS121/BACS series. It is a separate chipset, which can be attached to a CS121/BASC and it works as a Hardware watchdog to reset (cold boot) the processor, if a heartbeat signal is not received in an interval of 60 seconds.

Watchdog function: The watchdog starts 5 minutes after the CS121 has rebooted. If then the Watchdog does not receive within 120 seconds no alive signal from the processor, it will disconnect the power supply for a reset.

Powermanager function: Additionally this device checks the input power supply and blocks the startup of the processor until the power supply is stabilized and has reached at least a level of 8 Volt. This avoids startup problems at non stabilized power supplies or other power supply problems in UPS slots.

This product is designed to work as add-on for all CS121 based products with an internal connector such as all BACS WEBMANAGER BUDGET, CS121 SC,L,SCM,LM and the CS121 BUDGET series with 16MB flash ROM built after 2010.

Installation: To mount the CS121WDP Piggy Board on the CS121 Board, be sure, that the power supply is disconnected. Plug the CS121WDP Board on the CS121-Board like in the below pictures. The Piggy Board runs without any configuration and starts his functions immediately after connection. For using the Watchdog functionality, a firmware release after FW 4.28 is required. The Powermanager function is not depending on any FW level.

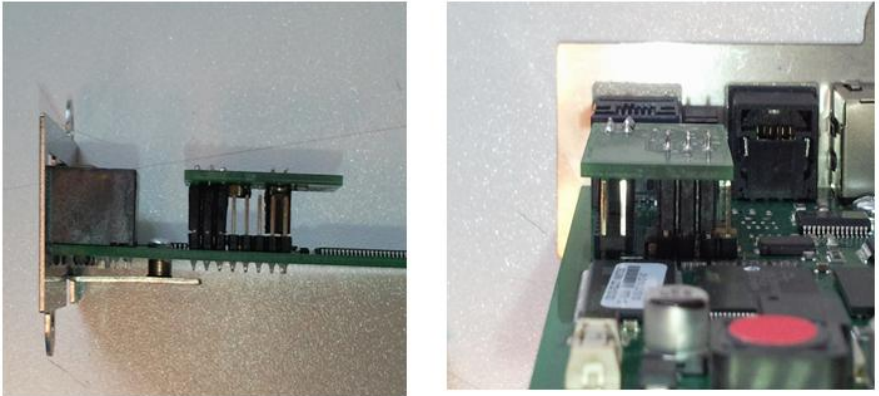

Figure 146: CS121 WDP piggyboard installed on a CS121 SC/BSC – view from left and behind

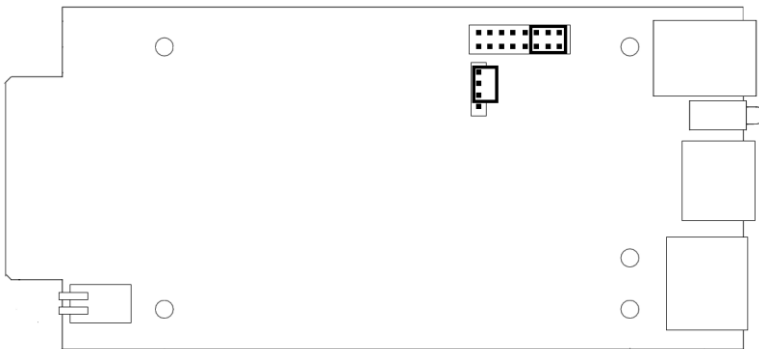

Figure 147: CS121 WDP connecting PINs on a CS121 SC/BSC board – top view

E. MODBUS Interface

E.1. General information

For remote control and monitoring of devices the MODBUS interface in each CS121 M can read out measurement values, events, status and other information in a master-slave protocol.



Note: Please note that not all UPS models support all or specific measurement values (e.g. battery low).

Communication Parameters:

ASCII Mode works at CS131 & CS121 platforms with communication parameters 7/E/2, or 7/E/1 or with 7/N/2 from baudrate 1200 to 38400. We recommend for ASCII the use of 7/N/2 and the highest baudrate supported by your device.

RTU Mode works at CS131 & CS121 platforms with communication parameters 8/E/1 or 8/N/2 or 8/N/1 or 8/E/2 or 8/O/2 or with 8/O/1 from baudrate 1200 to 38400. We recommend for RTU the use of 8/E/1 and the highest baudrate supported by your device.

MODBUS Parameter

Modus	Parität	DataBits	StoppBits
RTU	None	8	1
RTU	Even	8	1
RTU	Odd	8	1
ASCII	None	7	2
ASCII	Even	7	1
ASCII	Odd	7	1

If you receive faulty answers (Timeout Errors, Transaction ID Errors, Write Errors etc.), it may be, that the polling cycle was defined to fast. This causes the non answered polling requests or even a reboot of the CS121 through the integrated Watchdog, because the system is overloaded. Further on it can come to delayed answers during the MODBUS over IP or rather RS485 polling due to traffic into the bus or network, because the CS121 is a multi device, which has to handle several tasks at the same time.

NOTE: Please define a **response timeout** of at least 2000ms (at a fast MODBUS over IP or RS485 network/bus or rather higher accordingly, e.g. 4000ms at slow connections). The timeout has to be increased until the errors stay out.

E.2. Available Modbus Function Codes

Implemented MODBUS functions in the CS121 M units:

01H	Read Coils
02H	Read Discrete Inputs
03H	Read Holding Registers
04H	Read Input Registers
05H	Write Single Coil

Which functions are supported depends on the connected UPS. For standard UPS only functions 03H and 04H are available. In this case the CS121 M makes no difference between function 03H and 04H. The baud rate is adjustable up to 38400 Baud.



Note: Please note that the MODBUS adapter client allows a timeout of 40ms at 9600 baud for one value.

E.3. Exception Codes

Except for broadcast messages, when a master device sends a query to a slave device it expects a normal response. One of four possible events can occur from the master's query:

If the slave device receives the query without a communication error, and can handle the query normally, it returns a normal response.

If the slave does not receive the query due to a communication error, no response is returned. The master program will eventually process a timeout condition for the query.

If the slave receives the query, but detects a communication error parity, LRC, or CRC, no response is returned. The master program will eventually process a timeout condition for the query.

If the slave receives the query without a communication error, but cannot handle it (for example, if the request is to read a non-existent register) the slave will return an exception response informing the master of the nature of the error.

Available Exception codes:

Code	Meaning	
01H	Illegal The command received in the query is not defined.	Function:
02H	Illegal The address received in the query is not defined for the slave.	Address:
04H	Slave Internal slave device error.	Device Failure:

E.4. MODBUS Modes in the CS121 M (ASCII and RTU)

MODBUS Command

The following tables contain the general command descriptions and examples with ASCII and RTU framing.

Read Words (Functions 03h and 04h)

For the CS121 there is normally no difference between these two functions.

Query:

slave no	function code	address of first word to read		word count		Checksum LRC or CRC
1 byte	1 byte	High byte	Low byte	High byte	Low byte	1 or 2 byte(s)

Answer:

slave no	function code	Byte count	high byte of first word	low byte of first word	bytes with contents of n words	Checksum LRC or CRC
1 byte	1 byte	1 byte	1 byte	1 byte	n * 2 bytes	1 or 2 byte(s)

Example: Read Words, Function 04h, ASCII Mode

Read one word at address 63h (= 99 decimal):

Query:

Byte	1	2, 3	4, 5	6, 7	8, 9	10, 11	12, 13	14, 15	16	17

Meaning	Leading colon	Slave number	Function code	address of first word to read		word count to read		LRC	Carriage return	line feed LF
				high byte	low byte	high byte	low byte			
ASCII	:	0 1	0 4	0 0	6 3	0 0	0 1	9 7	<CR>	<LF>
HEX	[3A]	[30][31]	[30][34]	[30][30]	[36][33]	[30][30]	[30][31]	[39][37]	[0D]	[0A]

Answer:

Byte	1	2, 3	4, 5	6, 7	8, 9	10, 11	12, 13	14	15
Meaning	leading colon	Slave number	function code	byte count	contents of the word	LRC	carriage return	line feed LF	
					high byte	low byte			
ASCII	:	0 1	0 4	0 2	1 2	3 4	B 3	<CR>	<LF>
HEX	[3A]	[30][31]	[30][34]	[30][32]	[31][32]	[33][34]	[42][33]	[0D]	[0A]

ASCII: Data, which will send over the link as ASCII characters.

HEX: Hexadecimal values of the data

→ The word at address contains the value 1234h = 4660 decimal.

Example: Read Words, Function 04h, RTU Mode

Read one word at address 63h (= 99 decimal):

Query:

Byte		1	2	3	4	5	6	7	8	
Meaning	silent interval ≥ 3.5 characters	Slave number	function code	address of first word to read	high byte low byte	word read high byte low byte	count to read low byte	CRC low byte	High byte	silent interval ≥ 3.5 characters
RTU HEX		[01]	[04]	[00]	[63]	[00]	[01]	[C1]	[D4]	

Answer:

Byte		1	2	3	4	5	6	7
Meaning	silent interval ≥ 3.5 characters	Slave number	function code	byte count	Contents of the word	CRC	Silent interval ≥ 3.5 characters	
RTU HEX					high byte	low byte	low byte	high byte
		[01]	[04]	[02]	[12]	[34]	[B4]	[47]

→ The word at address contains the value 1234h = 4660 decimal.

E.5. UPS Parameter

Standard UPS – Address Description

Please note that this is just an example for a typical UPS, not every UPS has all these values, some UPS may have more, some less. Please contact your UPS manufacturer to check which variables are available and which requests are not supported.

Note: "Type U/S": this defines whether the answer has an algebraic sign (math. +/-) or not. U means "unsigned". S means "signed", this answer may be positive or negative.



Some clients (e. g. MODBUS Poll) use "MODBUS addresses" with a valid range of 0-65535, but some other clients use the "MODBUS register" with a valid range of 1-65536. In this case it is required to add a "1" to the MODBUS address you want to poll.



If you are using a PILLER UPS with a CS121 firmware version 4.29.3 or higher, please take a look into the UPS user manual for the accordant MODBUS values. If you are using a BACS system at the same time, no BACS values will be available via MODBUS.

Address	Type	Function	Name	Description	Length
97	U	3 / 4	OUTPUT_VOLT0	Output Voltage Phase 1 in V	1
98	U	3 / 4	OUTPUT_VOLT1	Output Voltage Phase 2 in V	1
99	U	3 / 4	OUTPUT_VOLT2	Output Voltage Phase 3 in V	1
100	U	3 / 4	OUTPOWER0	Outpower Phase 1 %	1
101	U	3 / 4	OUTPOWER1	Outpower Phase 2 %	1
102	U	3 / 4	OUTPOWER2	Outpower Phase 3 %	1
103	U	3 / 4	BATTCAP	Battery Capacity %	1
104	S	3 / 4	INVOLT0	Input Voltage Phase 1 V	1
105	S	3 / 4	INVOLT1	Input Voltage Phase 2 V	1
106	S	3 / 4	INVOLT2	Input Voltage Phase 3 V	1
107	S	3 / 4	TEMPDEG	Temperature C°	1
108	S	3 / 4	AUTONOMTIME	Autonomy Time minutes	1
109	U	3 / 4	STATUS (e. g. UPS normal = "4", Powerfail = "12", Battery test running = "68", Bypass = "5")	UPS Status (ASCII HEX) Please note UPSMAN status bytes table below	1
110	S	3 / 4	BATTVOLT	Battery Voltage V	1
111	U	3 / 4	INFREQ0	Input Frequency Hz Phase 1	1
112	U	3 / 4	INFREQ1	Input Frequency Hz Phase 2	1
113	U	3 / 4	INFREQ2	Input Frequency Hz Phase 3	1
114	U	3 / 4	CNT_PF	Powerfail Counter	1
115	U	3 / 4	Alarm Battery Bad	1 = active; 0 = not active	1
116	U	3 / 4	Alarm: On Battery	1 = active; 0 = not active	1
117	U	3 / 4	Alarm: Battery Low	1 = active; 0 = not active	1
118	U	3 / 4	Alarm: Battery Depleted	1 = active; 0 = not active	1
119	U	3 / 4	Alarm: Over temperature	1 = active; 0 = not active	1
120	U	3 / 4	Alarm: Input Bad	1 = active; 0 = not active	1
121	U	3 / 4	Alarm: Output Bad	1 = active; 0 = not active	1
122	U	3 / 4	Alarm: Output Overload	1 = active; 0 = not active	1
123	U	3 / 4	Alarm: On Bypass	1 = active; 0 = not active	1
124	U	3 / 4	Alarm: Bypass Bad	1 = active; 0 = not active	1
125	U	3 / 4	Alarm: Output Off as requested.	1 = active; 0 = not active	1
126	U	3 / 4	Alarm: UPS Off as requested.	1 = active; 0 = not active	1
127	U	3 / 4	Alarm: Charger Failed	1 = active; 0 = not active	1
128	U	3 / 4	Alarm: UPS Output Off	1 = active; 0 = not active	1
129	U	3 / 4	Alarm: UPS System Off	1 = active; 0 = not active	1
130	U	3 / 4	Alarm: Fan Failure	1 = active; 0 = not active	1
131	U	3 / 4	Alarm: fuse failure	1 = active; 0 = not active	1
132	U	3 / 4	Alarm: general fault	1 = active; 0 = not active	1
133	U	3 / 4	Alarm: diagnose test failed	1 = active; 0 = not active	1

134	U	3 / 4	Alarm: communication lost	1 = active; 0 = not active	1
135	U	3 / 4	Alarm: awaiting power	1 = active; 0 = not active	1
136	U	3 / 4	Alarm: shutdown pending	1 = active; 0 = not active	1
137	U	3 / 4	Alarm: shutdown imminent	1 = active; 0 = not active	1
138	U	3 / 4	Alarm: test in progress	1 = active; 0 = not active	1
139	U	3 / 4	AUX Port 1	1 = active (high) 0 = not active (low)	1
140	U	3 / 4	AUX Port 2	1 = active (high) 0 = not active (low)	1
141	U	3 / 4	AUX Port 3	1 = active (high) 0 = not active (low)	1
142	U	3 / 4	AUX Port 4	1 = active (high) 0 = not active (low)	1
143	U	3 / 4	Sensormanager/SMTCOM sensor 1	Analog value	1
144	U	3 / 4	Sensormanager/SMTHCOM sensor 2	Analog value	1
145	U	3 / 4	Sensormanager sensor 3	Analog value	1
146	U	3 / 4	Sensormanager sensor 4	Analog value	1
147	U	3 / 4	Sensormanager sensor 5	Analog value	1
148	U	3 / 4	Sensormanager sensor 6	Analog value	1
149	U	3 / 4	Sensormanager sensor 7	Analog value	1
150	U	3 / 4	Sensormanager sensor 8	Analog value	1

Section OEM		NEWAVE UPS			
99	U	1 6	Timesynchronization signal	Command 16 (write) : When this signal is set, the CS121 sets the internal clock to 01:00 of the same day. Command 3 or 4 (read) is not allowed.	1
139	U	3 / 4	Manual Bypass Switch Closed	0 = open 1 = closed	1
140	U	3 / 4	OUTPUT_VOLT0	Outputvoltage Phase 1	1
141	U	3 / 4	OUTPUT_VOLT1	Outputvoltage Phase 2	1
142	U	3 / 4	OUTPUT_VOLT2	Outputvoltage Phase 3	1
143	U	3 / 4	OutputCurrent Phase A * 10	Output Current Phase 1 in Ampere *10	1
144	U	3 / 4	OutputCurrent Phase B * 10	Output Current Phase 1 in Ampere *10	1
145	U	3 / 4	OutputCurrent Phase C * 10	Output Current Phase 1 in Ampere *10	1
146	U	3 / 4	xid3017 Bits 0-15	Statusbit of UPS 1 = true, 0 = false	1
147	U	3 / 4	xid3017 Bits 16-31	Statusbit, for details please contact NEWAVE	1
148	U	3 / 4	xid645 Bits 0-15	Alarmbit, for details please contact NEWAVE	1
149	U	3 / 4	xid645 Bits 16-31	Alarmbit, for details please contact NEWAVE	1
150	U	3 / 4	xid645 Bits 32-47	Alarmbit, for details please contact NEWAVE	1

151	U	3 / 4	xid645 Bits 48-63	Alarmbit, for details please contact NEWAVE	1
152	U	3 / 4	Sensormanager/SMTCOM sensor 1	Analog value	1
153	U	3 / 4	Sensormanager/SMTHCOM sensor 2	Analog value	1
154	U	3 / 4	Sensormanager sensor 3	Analog value	1
155	U	3 / 4	Sensormanager sensor 4	Analog value	1
156	U	3 / 4	Sensormanager sensor 5	Analog value	1
157	U	3 / 4	Sensormanager sensor 6	Analog value	1
158	U	3 / 4	Sensormanager sensor 7	Analog value	1
159	U	3 / 4	Sensormanager sensor 8	Analog value	1
160	U	3 / 4	TrueOutputPower Phase A in KW	True Output Power Current Phase 1 in Kilowatt	1
161	U	3 / 4	TrueOutputPower Phase A in KW	True Output Power Current Phase 1 in Kilowatt	1
162	U	3 / 4	TrueOutputPower Phase A in KW	True Output Power Current Phase 1 in Kilowatt	1
163	U	3 / 4	AUX Port 1	1 = active (high) 0 = not active (low)	1
164	U	3 / 4	AUX Port 2	1 = active (high) 0 = not active (low)	1
165	U	3 / 4	AUX Port 3	1 = active (high) 0 = not active (low)	1
166	U	3 / 4	AUX Port 4	1 = active (high) 0 = not active (low)	1

Section OEM		MASTERGUARD			
139	U	3 / 4	PXWARN		2
141	U	3 / 4	FAULT CODE 1		1
142	U	3 / 4	FAULT CODE 2		1
143	U	3 / 4	FAULT CODE 3		1
144	U	3 / 4	FAULT CODE 4		1
145	U	3 / 4	BADBATTBLOCK 1		1
146	U	3 / 4	BADBATTBLOCK 1		1
147	U	3 / 4	BADBATTBLOCK 1		1
148	U	3 / 4	BADBATTBLOCK 1		1
149	U	3 / 4	BADBATTBLOCK 1		1
150	U	3 / 4	BADBATTBLOCK 1		1

Section OEM		RITTAL			
Digital Input Status(DI)					
0	bit	2	Bypass working	Status 0: Normal, Status 1: Alert	1
1	bit	2	Bypass Interruption	Status 0: Normal, Status 1: Alert	1
2	bit	2	Rectifier Failure	Status 0: Normal, Status 1: Alert	1
3	bit	2	Inverter Failure	Status 0: Normal, Status 1: Alert	1
4	bit	2	Over Temperature	Status 0: Normal, Status 1: Alert	1

5	bit	2	Over Load	Status 0: Normal, Status 1: Alert	1
6	bit	2	0	Status 0: Normal, Status 1: Alert	1
7	bit	2	Battery Voltage too Low	Status 0: Normal, Status 1: Alert	1
8	bit	2	Fuse broken	Status 0: Normal, Status 1: Alert	1
9	bit	2	Battery discharging	Status 0: Normal, Status 1: Alert	1
10	bit	2	0	Status 0: Floating charge Status 1: Instant charging	1
11~30	bit	2	For future expansion		1
After 31	bit	2	Venders own definition		1
Analog Measurement point (AI)					
00	word	4	U in R phase input voltage	0.1 Volt	2
01	word	4	U in S phase input voltage	0.1 Volt	2
02	word	4	U in T phase input voltage	0.1 Volt	2
03	word	4	I in R phase input current	0.1A	2
04	word	4	I in S phase input current	0.1A	2
05	word	4	I in T phase input current	0.1A	2
06	word	4	F input frequency	0.1Hz	2
07	word	4	U out R phase output voltage	0.1 Volt	2
08	word	4	U out S phase output voltage	0.1 Volt	2
09	word	4	U out T phase output voltage	0.1 Volt	2
10	word	4	I out R phase output current	0.1A	2
11	word	4	I out S phase output current	0.1A	2
12	word	4	I out T phase output current	0.1A	2
13	word	4	P out output power	0.1kVA	2
14	word	4	P out output power	0.1kW	2
15	word	4	PF output power factor	0.01Cos	2
16	word	4	U Bypass R phase voltage	0.1 Volt	2
17	word	4	U Bypass S phase voltage	0.1 Volt	2
18	word	4	U Bypass T phase voltage	0.1 Volt	
19	word	4	F out output frequency	0.1Hz	

20	word	4	U Bat battery voltage	0.1 Volt	
21	word	4	I charch Bat battery charging/discharging	0.1A	
22	word	4	Temp 1 battery temperature	0.1 degC	
23	word	4	Temp 2 battery temperature	0.1 degC	
24	word	4	Temp 3 battery temperature	0.1 degC	
25	word	4	Temp 4 battery temperature	0.1 degC	
26	word	4	Temp 5 UPS shelf temperature	0.1 degC	

Digital output (DO)

Function 1 to read data; 5 to control the function

0	bit	1 / 5	UPS Turn On		
1	bit	1 / 5	UPS Shut down		
2	bit	1 / 5	Alarm Reset		
3	bit	1 / 5	Battery Instant Charging		
4	bit	1 / 5	Battery Floating Charging		
5~10	bit		For future expansion		
After			Vender self definition		

Section OEM			Rittal PMC Extension	New from firmware 4.50.14	CS121 version
100	U	3 / 4	OUTPOWER0	True Output Power Current Phase 1 in Kilowatt	1
101	U	3 / 4	OUTPOWER1	True Output Power Current Phase 2 in Kilowatt	1
102	U	3 / 4	OUTPOWER2	True Output Power Current Phase 3 in Kilowatt	1
103	U	3 / 4	BATTCAP	Battery Capacity	1
104	U	3 / 4	INVOLT0	Input Voltage Phase 1	1
105	U	3 / 4	INVOLT1	Input Voltage Phase 2	1
106	U	3 / 4	INVOLT2	Input Voltage Phase 3	1
107	U	3 / 4	TEMPDEG	Temperature in Degree C°	1
108	U	3 / 4	AUTONOMTIME	Autonomy Time in Minutes	1
109	U	3 / 4	STATUS	UPS Status (ASCII HEX) Please note UPSMAN status bytes table below	1
110	U	3 / 4	BATTVOLT	Battery Voltage	1
111	U	3 / 4	INFREQ0	Input Frequency Phase 1 in Hz	1
112	U	3 / 4	INFREQ1	Input Frequency Phase 2 in Hz	1
113	U	3 / 4	INFREQ2	Input Frequency Phase 3 in Hz	1
114	U	3 / 4	CNT_PF	Powerfail Counter	1
115	U	3 / 4	SNMP Alarm	Alarmbit, for details please contact NEWAVE	1

116	U	3 / 4	SNMP Alarm	Alarmbit, for details please contact NEWAVE	1
117	U	3 / 4	SNMP Alarm	Alarmbit, for details please contact NEWAVE	1
118	U	3 / 4	SNMP Alarm	Alarmbit, for details please contact NEWAVE	1
119	U	3 / 4	SNMP Alarm	Alarmbit, for details please contact NEWAVE	1
120	U	3 / 4	SNMP Alarm	Alarmbit, for details please contact NEWAVE	1
121	U	3 / 4	SNMP Alarm	Alarmbit, for details please contact NEWAVE	1
122	U	3 / 4	SNMP Alarm	Alarmbit, for details please contact NEWAVE	1
123	U	3 / 4	SNMP Alarm	Alarmbit, for details please contact NEWAVE	1
124	U	3 / 4	SNMP Alarm	Alarmbit, for details please contact NEWAVE	1
125	U	3 / 4	SNMP Alarm	Alarmbit, for details please contact NEWAVE	1
126	U	3 / 4	SNMP Alarm	Alarmbit, for details please contact NEWAVE	1
127	U	3 / 4	SNMP Alarm	Alarmbit, for details please contact NEWAVE	1
128	U	3 / 4	SNMP Alarm	Alarmbit, for details please contact NEWAVE	1
129	U	3 / 4	SNMP Alarm	Alarmbit, for details please contact NEWAVE	1
130	U	3 / 4	SNMP Alarm	Alarmbit, for details please contact NEWAVE	1
131	U	3 / 4	SNMP Alarm	Alarmbit, for details please contact NEWAVE	1
132	U	3 / 4	SNMP Alarm	Alarmbit, for details please contact NEWAVE	1
133	U	3 / 4	SNMP Alarm	Alarmbit, for details please contact NEWAVE	1
134	U	3 / 4	SNMP Alarm	Alarmbit, for details please contact NEWAVE	1
135	U	3 / 4	SNMP Alarm	Alarmbit, for details please contact NEWAVE	1
136	U	3 / 4	SNMP Alarm	Alarmbit, for details please contact NEWAVE	1
137	U	3 / 4	SNMP Alarm	Alarmbit, for details please contact NEWAVE	1
138	U	3 / 4	SNMP Alarm	Alarmbit, for details please contact NEWAVE	1
139	U	3 / 4	Status Bit	Statusbit, for details please contact NEWAVE	1
140	U	3 / 4	OUTPUT_VOLT0	Output Voltage Phase 1	1
141	U	3 / 4	OUTPUT_VOLT1	Output Voltage Phase 2	1
142	U	3 / 4	OUTPUT_VOLT2	Output Voltage Phase 1	1
143	U	3 / 4	OUTPUT_CURR0	Output Current Phase 1 in KW	1
144	U	3 / 4	OUTPUT_CURR1	Output Current Phase 2 in KW	1

145	U	3 / 4	OUTPUT_CURR2	Output Current Phase 3 in KW	1
146	U	3 / 4	Status Bit	Statusbit, for details please contact NEWAVE	1
147	U	3 / 4	Status Bit	Statusbit, for details please contact NEWAVE	1
148	U	3 / 4	Status Bit	Statusbit, for details please contact NEWAVE	1
149	U	3 / 4	Status Bit	Statusbit, for details please contact NEWAVE	1
150	U	3 / 4	Status Bit	Statusbit, for details please contact NEWAVE	1
151	U	3 / 4	Status Bit	Statusbit, for details please contact NEWAVE	1
152	U	3 / 4	TEMP1	SensorManager/SM_T_H_CO M Analog Value	1
153	U	3 / 4	TEMP2	SensorManager/SM_T_H_CO M Analog Value	1
154	U	3 / 4	TEMP3	SensorManager Analog Value	1
155	U	3 / 4	TEMP4	SensorManager Analog Value	1
156	U	3 / 4	TEMP5	SensorManager Analog Value	1
157	U	3 / 4	TEMP6	SensorManager Analog Value	1
158	U	3 / 4	TEMP7	SensorManager Analog Value	1
159	U	3 / 4	TEMP8	SensorManager Analog Value	1
160	U	3 / 4	LOADKVA0	Load Phase 1 in KW	1
161	U	3 / 4	LOADKVA1	Load Phase 2 in KW	1
162	U	3 / 4	LOADKVA2	Load Phase 3 in KW	1

Section OEM	Netminder for all LT and MD types
--------------------	--

Address	Type	Function	Name	Description	Length
100	U	3/4	INVOLT	Input Voltage	1
101	U	3/4	OUTPUTVOLT	Output Voltage	1
102	U	3/4	BATTVOLT	Battery Voltage	1
103	U	3/4	OUTPUTCURR	Output Current	1
104	U	3/4	LOADPERC	Load (%)	1
105	U	3/4	OUTPUTPOW	Output Power in W	1
106	U	3/4	KVA	KVA	1
107	U	3/4	FREQUENCY	Frequency	1
108	U	3/4	CS121UPSSTAT	CS121 UPS Status	1
109	U	3/4	Alarm: Battery Bad	1 = active; 0 = not active	1
110	U	3/4	Alarm: On Battery	1 = active; 0 = not active	1
111	U	3/4	Alarm: Battery Low	1 = active; 0 = not active	1
112	U	3/4	Alarm: Battery Depleted	1 = active; 0 = not active	1

113	U	3/4	Alarm: Overtemperature	1 = active; 0 = not active	1
114	U	3/4	Alarm: Input Bad	1 = active; 0 = not active	1
115	U	3/4	Alarm: Output Bad	1 = active; 0 = not active	1
116	U	3/4	Alarm: Output Overload	1 = active; 0 = not active	1
117	U	3/4	Alarm: On Bypass	1 = active; 0 = not active	1
118	U	3/4	Alarm: Bypass Bad	1 = active; 0 = not active	1
119	U	3/4	Alarm: Output Off As Requested	1 = active; 0 = not active	1
120	U	3/4	Alarm: UPS Off As Requested	1 = active; 0 = not active	1
121	U	3/4	Alarm: Charger Failed	1 = active; 0 = not active	1
122	U	3/4	Alarm: UPS Output Off	1 = active; 0 = not active	1
123	U	3/4	Alarm: UPS System Off	1 = active; 0 = not active	1
124	U	3/4	Alarm: Fan Failure	1 = active; 0 = not active	1
125	U	3/4	Alarm: Fuse Failure	1 = active; 0 = not active	1
126	U	3/4	Alarm: General Fault	1 = active; 0 = not active	1
127	U	3/4	Alarm: Diagnosis Test Failed	1 = active; 0 = not active	1
128	U	3/4	Alarm: Communication Lost	1 = active; 0 = not active	1
129	U	3/4	Alarm: Awaiting Power	1 = active; 0 = not active	1
130	U	3/4	Alarm: Shutdown Pending	1 = active; 0 = not active	1
131	U	3/4	Alarm: Shutdown Imminent	1 = active; 0 = not active	1
132	U	3/4	Alarm: Test In Progress	1 = active ; 0 = not active	1
133	U	3/4	AUX Port 1	1 = active (high) ; 0 = not active (low)	1
134	U	3/4	AUX Port 2	1 = active (high) ; 0 = not active (low)	1
135	U	3/4	AUX Port 3	1 = active (high) ; 0 = not active (low)	1
136	U	3/4	AUX Port 4	1 = active (high) ; 0 = not active (low)	1

137	U	3/4	SensorManager/SMTH_COM, Sensor 1	Analog Value	1
138	U	3/4	SensorManager/SMTH_COM, Sensor 2	Analog Value	1
139	U	3/4	SensorManager/Sensor 3	Analog Value	1
140	U	3/4	SensorManager/Sensor 4	Analog Value	1
141	U	3/4	SensorManager/Sensor 5	Analog Value	1
142	U	3/4	SensorManager/Sensor 6	Analog Value	1
143	U	3/4	SensorManager/Sensor 7	Analog Value	1
144	U	3/4	SensorManager/Sensor 8	Analog Value	1

Section OEM		Netminder EON			
1	U	3 / 4	Manufacturer	Manufacturer	1
17	U	3 / 4	Version	Version	1
33	U	3 / 4	Identification	Identification	1
65	U	3 / 4	MODEL	UPS Model	1
97	U	3 / 4	AUTONOMTIME	Autonomy time in minutes	1
98	U	3 / 4	BATTCAP	Battery capacity in percent	1
99	U	3 / 4	OUTFREQ0	Output Frequency	1
100	U	3 / 4	OUTPUTVOLT0	Output Voltage Phase 1	1
101	U	3 / 4	OUTPUTVOLT1	Output Voltage Phase 2	1
102	U	3 / 4	OUTPUTVOLT1	Output Voltage Phase 3	1
103	U	3 / 4	OUTPOWER0	Outpower Phase 1 in %	1
104	U	3 / 4	OUTPOWER1	Outpower Phase 2 in %	1
105	U	3 / 4	OUTPOWER2	Outpower Phase 3 in %	1
106	U	3 / 4	OUTPOWER0	Outpower Phase 1 in VA	1
107	U	3 / 4	OUTPOWER1	Outpower Phase 2 in VA	1
108	U	3 / 4	OUTPOWER2	Outpower Phase 3 in VA	1
109	U	3 / 4	INPUTFREQ0	Input Frequency Phase 1 in Hz	1
110	U	3 / 4	INPUTFREQ1	Input Frequency Phase 2 in Hz	1
111	U	3 / 4	INPUTFREQ2	Input Frequency Phase 3 in Hz	1
112	U	3 / 4	INPUTVOLT0	Input Voltage Phase 1 in V	1
113	U	3 / 4	INPUTVOLT1	Input Voltage Phase 2 in V	1
114	U	3 / 4	INPUTVOLT2	Input Voltage Phase 3 in V	1
115	U	3 / 4	INPUTCURR0	Input Current Phase 1 in A	1
116	U	3 / 4	INPUTCURR1	Input Current Phase 2 in A	1
117	U	3 / 4	INPUTCURR2	Input Current Phase 3 in A	1
118	U	3 / 4	INPUTPOW0	Input Power Phase 1 in W	1
119	U	3 / 4	INPUTPOW1	Input Power Phase 2 in W	1
120	U	3 / 4	INPUTPOW1	Input Power Phase 3 in W	1
121	U	3 / 4	BATTVOLT	Battery Voltage in V	1
122	U	3 / 4	BATTTEMPDEG	Battery Temperature in Degree Celsius	1
123	U	3 / 4	BATTSEC	Seconds on Battery	1
124	U	3 / 4	Battery Condition	Battery Condition	1
125	U	3 / 4	Amount of Input Phases	Amount of Input Phases	1
126	U	3 / 4	Amount of Output Phases	Amount of Output Phases	1

127	U	3 / 4	Results of Battery Test	1 Ok, 2 Active, 3 Canceled, 4 Failed, else: not started yet	1
128	U	3 / 4	Powerfail	Powerfail	1
129	U	3 / 4	System Shutdown	System Shutdown	1
130	U	3 / 4	UPSMAN started	UPSMAN started	1
131	U	3 / 4	UPS Connection lost	UPS connection lost	1
132	U	3 / 4	UPS Battery old	UPS Battery old	1
133	U	3 / 4	Load >80%	Load >80%	1
134	U	3 / 4	Load >90%	Load >90%	1
135	U	3 / 4	Overload	Overload	1
136	U	3 / 4	Overtemperature Condition	Overtemperature Condition	1
137	U	3 / 4	Bypass on	Bypass on	1
138	U	3 / 4	Battery low	Battery low	1
139	U	3 / 4	Batteries are weak	Batteries are weak	1
140	U	3 / 4	General Alarm Condition	General Alarm Condition	1
141	U	3 / 4	Input Bad Condition	Input Bad Condition	1
142	U	3 / 4	Output Bad Condition	Output Bad Condition	1
143	U	3 / 4	Bypass Not Available	Bypass Not Available	1
144	U	3 / 4	Low Battery Shutdown	Low Battery Shutdown	1
145	U	3 / 4	System off	System off	1
146	U	3 / 4	System Shutdown	System Shutdown	1
147	U	3 / 4	Charger Failure	Charger Failure	1
148	U	3 / 4	Manual Restart Required	Manual Restart Required	1
149	U	3 / 4	Output Circuit Breaker Open	Output Circuit Breaker Open	1
150	U	3 / 4	Remote Emergency Power off	Remote Emergency Power off	1
151	U	3 / 4	Shutdown imminent	Shutdown imminent	1

Section OEM	Netminder for all other types	
--------------------	--------------------------------------	--

Address	Type	Function	Name	Description	Length
100	U	3/4	INVOLT	Input Voltage (I1-n)	1
101	U	3/4	INVOLT	Input Voltage (I2-n)	1
102	U	3/4	INVOLT	Input Voltage (I1-I2)	1
103	U	3/4	OUTPUTVOLT	Output Voltage (I1-n)	1
104	U	3/4	OUTPUTVOLT	Output Voltage (I2-n)	1
105	U	3/4	OUTPUTVOLT	Output Voltage /(I1-I2)	1
106	U	3/4	OUTPUTCURR	Output Current (I1-n)	1
107	U	3/4	OUTPUTCURR	Output Current (I2-n)	1
108	U	3/4	OUTPUTWAT	Output Watts (I1-n)	1
109	U	3/4	OUTPUTWAT	Output Watts (I2-n)	1
110	U	3/4	OUTPUTWAT	Output Watts (I1-I2)	1
111	U	3/4	OUTPUTWATTOT	Output watts (total)	1
112	U	3/4	OUTPUTVA	Output VA (I1-n)	1

113	U	3/4	OUTPUTVA	Output VA (I2-n)	1
114	U	3/4	OUTPUTVA	Output VA (I1-I2)	1
115	U	3/4	OUTPUTVATOT	Output VA (total)	1
116	U	3/4	OUTPUTLOAD	Output Load (I1-n)	1
117	U	3/4	OUTPUTLOAD	Output Load (I2-n)	1
118	U	3/4	OUTPUTFREQ	Output Frequency	1
119	U	3/4	BATTVOLT	Battery Voltage	1
120	U	3/4	PERCBATT	Percentage Battery	1
121	U	3/4	DCCHARGECURR	DC Charging Current	1
122	U	3/4	CS121UPSSTAT	CS121 UPS Status	1
123	U	3/4	Alarm: Battery Bad	1 = active; 0 = not active	1
124	U	3/4	Alarm: On Battery	1 = active; 0 = not active	1
125	U	3/4	Alarm: Battery Low	1 = active; 0 = not active	1
126	U	3/4	Alarm: Battery Depleted	1 = active; 0 = not active	1
127	U	3/4	Alarm: Overtemperature	1 = active; 0 = not active	1
128	U	3/4	Alarm: Input Bad	1 = active; 0 = not active	1
129	U	3/4	Alarm: Output Bad	1 = active; 0 = not active	1
130	U	3/4	Alarm: Output Overload	1 = active; 0 = not active	1
131	U	3/4	Alarm: On Bypass	1 = active; 0 = not active	1
132	U	3/4	Alarm: Bypass Bad	1 = active; 0 = not active	1
133	U	3/4	Alarm: Output Off As Requested	1 = active; 0 = not active	1
134	U	3/4	Alarm: UPS Off As Requested	1 = active; 0 = not active	1
135	U	3/4	Alarm: Charger Failed	1 = active; 0 = not active	1
136	U	3/4	Alarm: UPS Output Off	1 = active; 0 = not active	1
137	U	3/4	Alarm: UPS System Off	1 = active; 0 = not active	1
138	U	3/4	Alarm: Fan Failure	1 = active; 0 = not active	1
139	U	3/4	Alarm: Fuse Failure	1 = active; 0 = not active	1
140	U	3/4	Alarm: General Fault	1 = active; 0 = not active	1
141	U	3/4	Alarm: Diagnosis Test Failed	1 = active; 0 = not active	1
142	U	3/4	Alarm: Communication Lost	1 = active; 0 = not active	1

143	U	3/4	Alarm: Awaiting Power	1 = active; 0 = not active	1
144	U	3/4	Alarm: Shutdown Pending	1 = active; 0 = not active	1
145	U	3/4	Alarm: Shutdown Imminent	1 = active; 0 = not active	1
146	U	3/4	Alarm: Test In Progress	1 = active; 0 = not active	1
147	U	3/4	AUX Port 1	1 = active (high) ; 0 = not active (low)	1
148	U	3/4	AUX Port 2	1 = active (high) ; 0 = not active (low)	1
149	U	3/4	AUX Port 3	1 = active (high) ; 0 = not active (low)	1
150	U	3/4	AUX Port 4	1 = active (high) ; 0 = not active (low)	1
151	U	3/4	SensorManager/SMTH_COM, Sensor 1	Analog Value	1
152	U	3/4	SensorManager/SMTH_COM, Sensor 2	Analog Value	1
153	U	3/4	SensorManager/Sensor 3	Analog Value	1
154	U	3/4	SensorManager/Sensor 4	Analog Value	1
155	U	3/4	SensorManager/Sensor 5	Analog Value	1
156	U	3/4	SensorManager/Sensor 6	Analog Value	1
157	U	3/4	SensorManager/Sensor 7	Analog Value	1
158	U	3/4	SensorManager/Sensor 8	Analog Value	1

Secti on OEM	POWERTRONIX			
		MIZAR		
Adres se	Name	ALCOR	QUASAR	SUPERNOVAE
100	Outpower Phase 1 %	x	x	x
101	Outpower Phase 2 %	x	x	x
102	Outpower Phase 3 %	x	x	x
103	Battery Capacity %	x	x	x

104	Input Voltage Phase 1 V	x	x	x
105	Input Voltage Phase 2 V	x	x	x
106	Input Voltage Phase 3 V	x	x	x
107	Temperature °C	not supported	x	x
108	Autonomy Time minutes	x	x	x
109	UPS Status (ASCII Hex)	x	x	x
110	Battery Voltage V	x	x	x
111	Input Frequency Phase 1 Hz	not supported	x	not supported
112	Input Frequency Phase 2 Hz	not supported	x	not supported
113	Input Frequency Phase 3 Hz	not supported	x	not supported
114	Powerfail Counter	x	x	x
115	Alarm: Battery Bad	x	x	x
116	Alarm: On Battery	x	x	x
117	Alarm: Battery Low	not supported	not supported	x
118	Alarm: Battery Depleted	x	not supported	x
119	Alarm: Overtemperature	x	not supported	x
120	Alarm: Input Bad	x	x	x
121	Alarm: Output Bad	not supported	x	not supported
122	Alarm: Output Overload	x	x	x
123	Alarm: On Bypass	x	x	x
124	Alarm: Bypass Bad	x	x	x
125	Alarm: Output Off As Requested	x	x	x
126	Alarm: UPS Off As Requested	x	x	x
127	Alarm: Charger Failed		x	x
128	Alarm: UPS Output Off	x	x	x
129	Alarm: UPS Sytem Off	not supported	x	not supported
130	Alarm: Fan Failure	x	not supported	x
131	Alarm: Fuse Failure	not supported	not supported	not supported
132	Alarm: General Fault	x	x	x
133	Alarm: Diagnose Test Failed	not supported	not supported	not supported
134	Alarm: Communication Lost	x	x	x
135	Alarm: Awaiting Power	not supported	not supported	not supported

136	Alarm: Shutdown Pending	not supported	not supported	not supported
137	Alarm: Shutdown Imminent	not supported	not supported	not supported
138	Alarm: Test In Progress	x	not supported	not supported
139	AUX Port 1	x	x	x
140	AUX Port 2	x	x	x
141	AUX Port 3	x	x	x
142	AUX Port 4	x	x	x

Section		E-Tec 310 to 380 (m)	SALICRU SLC	
Borri 4000			NX/DL/CUBE	
Std. Panel				
1	U 3 / 4	Manufacturer	Manufacturer	1
17	U 3 / 4	Version	Version	1
33	U 3 / 4	Identification	Identification	1
65	U 3 / 4	Model	Model	1
97	U 3 / 4	AUTONOMTIME	Autonomy time in minutes	1
98	U 3 / 4	BATTCAP	Battery capacity in percent	1
99	U 3 / 4	OUTPUT	Output Source 0 Mains, 1 Battery, 2 Bypass	1
100	U 3 / 4	OUTFREQ0	Output Frequency	1
101	U 3 / 4	SOLAWROV0	Outputvoltage Phase 1 in V	1
102	U 3 / 4	SOLAWROV1	Outputvoltage Phase 2 in V	1
103	U 3 / 4	SOLAWROV2	Outputvoltage Phase 3 in V	1
104	U 3 / 4	SOLAWROC0	Output Current Phase 1 in A	1
105	U 3 / 4	SOLAWROC1	Output Current Phase 2 in A	1
106	U 3 / 4	SOLAWROC2	Output Current Phase 3 in A	1
107	U 3 / 4	OUTPOWER0	Outpower Phase 1 %	1
108	U 3 / 4	OUTPOWER1	Outpower Phase 2 %	1
109	U 3 / 4	OUTPOWER2	Outpower Phase 3 %	1
110	U 3 / 4	SOLSETEMPBAD	Temperature bad	1
111	U 3 / 4	SOLSEINPUTBAD	Input bad	1
112	U 3 / 4	SOLSEOVERLOAD	Overload	1
113	U 3 / 4	SOLSEBYPASSFAULT	Bypass fault	1
114	U 3 / 4	SOLSECHARGERFAULT	Charger fault	1
115	U 3 / 4	SOLSEGENERALFAULT	General fault	1
116	U 3 / 4	SOLSESDPENDING	Shutdown pending	1
117	U 3 / 4	SOLSETESTRESULT	Test result	1
118	U 3 / 4	(SNMPALARMS&0x80000)>>19	Communication Lost Alarm	1
119	U 3 / 4	INFREQ0	Input Frequency Phase 1 in Hz	1

120	U	3 / 4	INFREQ1	Input Frequency Phase 2 in Hz	1
121	U	3 / 4	INFREQ2	Input Frequency Phase 3 in Hz	1
122	U	3 / 4	INVOLT0	Input Voltage Phase 1 in V	1
123	U	3 / 4	INVOLT1	Input Voltage Phase 2 in V	1
124	U	3 / 4	INVOLT2	Input Voltage Phase 3 in V	1
125	U	3 / 4	INCURR0	Input Current Phase 1 in A	1
126	U	3 / 4	INCURR1	Input Current Phase 2 in A	1
127	U	3 / 4	INCURR2	Input Current Phase 3 in A	1
128	U	3 / 4	EX_BYP_VOLT0	Bypass Voltage Phase 1 in V	1
129	U	3 / 4	EX_BYP_VOLT1	Bypass Voltage Phase 2 in V	1
130	U	3 / 4	EX_BYP_VOLT2	Bypass Voltage Phase 3 in V	1
131	U	3 / 4	EX_BYP_CURR0	Bypass Current Phase 1 in A	1
132	U	3 / 4	EX_BYP_CURR1	Bypass Current Phase 2 in A	1
133	U	3 / 4	EX_BYP_CURR2	Bypass Current Phase 3 in A	1
134	U	3 / 4	EX_BYP_WATT0	Bypass Watt Phase 1	1
135	U	3 / 4	EX_BYP_WATT1	Bypass Watt Phase 2	1
136	U	3 / 4	EX_BYP_WATT2	Bypass Watt Phase 3	1

Section MHD Modular	Multimatic Modular	AEG Protect 1. Modular, ENIGMA
----------------------------	---------------------------	---------------------------------------

100	U	3 / 4	OUTPOWER0	Outpower Phase 1 %	1
101	U	3 / 4	OUTPOWER1	Outpower Phase 2 %	1
102	U	3 / 4	OUTPOWER2	Outpower Phase 3 %	1
103	U	3 / 4	BATTCAP	Battery Capacity %	1
104	S	3 / 4	INVOLT0	Input Voltage Phase 1 V	1
105	S	3 / 4	INVOLT1	Input Voltage Phase 2 V	1
106	S	3 / 4	INVOLT2	Input Voltage Phase 3 V	1
107	S	3 / 4	TEMPDEG	Temperature C°	1
108	S	3 / 4	AUTONOMTIME	Autonomy Time minutes	1
109	U	3 / 4	STATUS (e. g. UPS normal = "4", Powerfail = "12", Battery test running = "68", Bypass = "5")	UPS Status (ASCII HEX), please note UPSMAN status bytes table below	1
110	U	3 / 4	BATTVOLT	Battery Voltage V	1

111	U	3 / 4	INFREQ0	Input Frequency Hz Phase 1	1
112	U	3 / 4	INFREQ1	Input Frequency Hz Phase 2	1
113	U	3 / 4	INFREQ2	Input Frequency Hz Phase 3	1
114	U	3 / 4	CNT_PF	Powerfail Counter	1
115	U	3 / 4	(SNMPALARMS&0x1)	Alarm Battery Bad	1
116	U	3 / 4	(SNMPALARMS&0x2)>>1	Alarm: On Battery	1
117	U	3 / 4	(SNMPALARMS&0x4)>>2	Alarm: Battery Low	1
118	U	3 / 4	(SNMPALARMS&0x8)>>3	Alarm: Battery Depleted	1
119	U	3 / 4	(SNMPALARMS&0x10)>>4	Alarm: Over temperature	1
120	U	3 / 4	(SNMPALARMS&0x20)>>5	Alarm: Input Bad	1
121	U	3 / 4	(SNMPALARMS&0x40)>>6	Alarm: Output Bad	1
122	U	3 / 4	(SNMPALARMS&0x80)>>7	Alarm: Output Overload	1
123	U	3 / 4	(SNMPALARMS&0x100)>>8	Alarm: On Bypass	1
124	U	3 / 4	(SNMPALARMS&0x200)>>9	Alarm: Bypass Bad	1
125	U	3 / 4	(SNMPALARMS&0x400)>>10	Alarm: Output Off as requested.	1
126	U	3 / 4	(SNMPALARMS&0x800)>>11	Alarm: UPS Off as requested.	1
127	U	3 / 4	(SNMPALARMS&0x1000)>>1 2	Alarm: Charger Failed	1
128	U	3 / 4	(SNMPALARMS&0x2000)>>1 3	Alarm: UPS Output Off	1
129	U	3 / 4	(SNMPALARMS&0x4000)>>1 4	Alarm: UPS System Off	1
130	U	3 / 4	(SNMPALARMS&0x8000)>>1 5	Alarm: Fan Failure	1
131	U	3 / 4	(SNMPALARMS&0x10000)>> 1	Alarm: fuse failure	1
132	U	3 / 4	(SNMPALARMS&0x20000)>> 1	Alarm: general fault	1
133	U	3 / 4	(SNMPALARMS&0x40000)>> 1	Alarm: diagnose test failed	1
134	U	3 / 4	(SNMPALARMS&0x80000)>> 1	Alarm: communication lost	1
135	U	3 / 4	(SNMPALARMS&0x100000)> >	Alarm: awaiting power	1
136	U	3 / 4	(SNMPALARMS&0x200000)> >	Alarm: shutdown pending	1
137	U	3 / 4	(SNMPALARMS&0x400000)> >	Alarm: shutdown imminent	1
138	U	3 / 4	(SNMPALARMS&0x800000)> >	Alarm: test in progress	1

139	U	3 / 4	AUX1STATE	AUX Port 1	1
140	U	3 / 4	AUX2STATE	AUX Port 2	1
141	U	3 / 4	AUX3STATE	AUX Port 3	1
142	U	3 / 4	AUX4STATE	AUX Port 4	1
143	U	3 / 4	TEMP1	Sensormanager/SMTCOM sensor 1	1
144	U	3 / 4	TEMP2	Sensormanager/SMTHCOM sensor 2	1
145	U	3 / 4	TEMP3	Sensormanager sensor 3	1
146	U	3 / 4	TEMP4	Sensormanager sensor 4	1
147	U	3 / 4	TEMP5	Sensormanager sensor 5	1
148	U	3 / 4	TEMP6	Sensormanager sensor 6	1
149	U	3 / 4	TEMP7	Sensormanager sensor 7	1
150	U	3 / 4	TEMP8	Sensormanager sensor 8	1
151	U	3 / 4	AEESerModulePresent(1)	Status data, for details please contact Effekta directly	1
152	U	3 / 4	AEESerModulePresent(2)	Status data, for details please contact Effekta directly	1
153	U	3 / 4	AEESerModulePresent(3)	Status data, for details please contact Effekta directly	1
154	U	3 / 4	AEESerModulePresent(4)	Status data, for details please contact Effekta directly	1
155	U	3 / 4	AEESerModulePresent(5)	Status data, for details please contact Effekta directly	1
156	U	3 / 4	AEESerModulePresent(6)	Status data, for details please contact Effekta directly	1
157	U	3 / 4	AEESerModuleError(1,1)	Status data, for details please contact Effekta directly	1
158	U	3 / 4	AEESerModuleError(1,2)	Status data, for details please contact Effekta directly	1
159	U	3 / 4	AEESerModuleError(1,3)	Status data, for details please contact Effekta directly	1
160	U	3 / 4	AEESerModuleError(1,4)	Status data, for details please contact Effekta directly	1
161	U	3 / 4	AEESerModuleError(2,1)	Status data, for details please contact Effekta directly	1

162	U	3 / 4	AEESerModuleError(2,2)	Status data, for details please contact Effekta directly	1
163	U	3 / 4	AEESerModuleError(2,3)	Status data, for details please contact Effekta directly	1
164	U	3 / 4	AEESerModuleError(2,4)	Status data, for details please contact Effekta directly	1
165	U	3 / 4	AEESerModuleError(3,1)	Status data, for details please contact Effekta directly	1
166	U	3 / 4	AEESerModuleError(3,2)	Status data, for details please contact Effekta directly	1
167	U	3 / 4	AEESerModuleError(3,3)	Status data, for details please contact Effekta directly	1
168	U	3 / 4	AEESerModuleError(3,4)	Status data, for details please contact Effekta directly	1
169	U	3 / 4	AEESerModuleError(4,1)	Status data, for details please contact Effekta directly	1
170	U	3 / 4	AEESerModuleError(4,2)	Status data, for details please contact Effekta directly	1
171	U	3 / 4	AEESerModuleError(4,3)	Status data, for details please contact Effekta directly	1
172	U	3 / 4	AEESerModuleError(4,4)	Status data, for details please contact Effekta directly	1
173	U	3 / 4	AEESerModuleError(5,1)	Status data, for details please contact Effekta directly	1
174	U	3 / 4	AEESerModuleError(5,2)	Status data, for details please contact Effekta directly	1
175	U	3 / 4	AEESerModuleError(5,3)	Status data, for details please contact Effekta directly	1
176	U	3 / 4	AEESerModuleError(5,4)	Status data, for details please contact Effekta directly	1
177	U	3 / 4	AEESerModuleError(6,1)	Status data, for details please contact Effekta directly	1
178	U	3 / 4	AEESerModuleError(6,2)	Status data, for details please contact Effekta directly	1

179	U	3 / 4	AEESerModuleError(6,3)	Status data, for details please contact Effekta directly	1
180	U	3 / 4	AEESerModuleError(6,4)	Status data, for details please contact Effekta directly	1
181	U	3 / 4	AEESerModuleWarning(1)	Status data, for details please contact Effekta directly	1
182	U	3 / 4	AEESerModuleWarning(2)	Status data, for details please contact Effekta directly	1
183	U	3 / 4	AEESerModuleWarning(3)	Status data, for details please contact Effekta directly	1
184	U	3 / 4	AEESerModuleWarning(4)	Status data, for details please contact Effekta directly	1
185	U	3 / 4	AEESerModuleWarning(5)	Status data, for details please contact Effekta directly	1
186	U	3 / 4	AEESerModuleWarning(6)	Status data, for details please contact Effekta directly	1
187	U	3 / 4	AEESerModuleState(1)	Status data, for details please contact Effekta directly	1
188	U	3 / 4	AEESerModuleState(2)	Status data, for details please contact Effekta directly	1
189	U	3 / 4	AEESerModuleState(3)	Status data, for details please contact Effekta directly	1
190	U	3 / 4	AEESerModuleState(4)	Status data, for details please contact Effekta directly	1
191	U	3 / 4	AEESerModuleState(5)	Status data, for details please contact Effekta directly	1
192	U	3 / 4	AEESerModuleState(6)	Status data, for details please contact Effekta directly	1
193	U	3 / 4	AEESerModuleVolt(1)	Status data, for details please contact Effekta directly	1
194	U	3 / 4	AEESerModuleVolt(2)	Status data, for details please contact Effekta directly	1
195	U	3 / 4	AEESerModuleVolt(3)	Status data, for details please contact Effekta directly	1

196	U	3 / 4	AEESerModuleVolt(4)	Status data, for details please contact Effekta directly	1
197	U	3 / 4	AEESerModuleVolt(5)	Status data, for details please contact Effekta directly	1
198	U	3 / 4	AEESerModuleVolt(6)	Status data, for details please contact Effekta directly	1
199	U	3 / 4	AEESerModuleCurr(1)	Status data, for details please contact Effekta directly	1
200	U	3 / 4	AEESerModuleCurr(2)	Status data, for details please contact Effekta directly	1
201	U	3 / 4	AEESerModuleCurr(3)	Status data, for details please contact Effekta directly	1
202	U	3 / 4	AEESerModuleCurr(4)	Status data, for details please contact Effekta directly	1
203	U	3 / 4	AEESerModuleCurr(5)	Status data, for details please contact Effekta directly	1
204	U	3 / 4	AEESerModuleCurr(6)	Status data, for details please contact Effekta directly	1

Section Inform UPS		Pyramid DSP/Online DSP	Standard UPS values plus the following	
151	U 3 / 4	OUTPUT_VOLT0	Outputvoltage Phase 1	1
152	U 3 / 4	OUTPUT_VOLT1	Outputvoltage Phase 2	1
153	U 3 / 4	OUTPUT_VOLT2	Outputvoltage Phase 3	1
154	U 3 / 4	OUTPUT_CURRENT0	Output Current Phase 1 in Ampere *10	1
155	U 3 / 4	OUTPUT_CURRENT1	Output Current Phase 2 in Ampere *10	1
156	U 3 / 4	OUTPUT_CURRENT2	Output Current Phase 3 in Ampere *10	1

Section	Transfer Switches	All transfer switch vendors, except PILLER	
1	U 3 / 4 Sources Asynchronous	Warning, input current difference, switching might not be possible	1
2	U 3 / 4 Static Switch A Failure	Alarm, switching failure	1
3	U 3 / 4 Static Switch B Failure	Alarm, switching failure	1
4	U 3 / 4 On Static Switch A	Supplied from input A	1
5	U 3 / 4 On Static Switch B	Supplied from input B	1
6	U 3 / 4 On Manual Bypass A	Supplied via bypass from input A	1
7	U 3 / 4 On Manual Bypass A	Supplied via bypass from input B	1

8	U 3 / 4	Source A Failure	Alarm, input A failure, problem with voltage	1
9	U 3 / 4	Source B Failure	Alarm, input B failure, problem with voltage	1
10	U 3 / 4	General Fault	General alarm	1
11	U 3 / 4	Redundancy Lost	Redundancy lost,	1
12	U 3 / 4	Output Overload	To much load	1
13	U 3 / 4	Output Failure	Output failure	1

Section	STS TUMEL	Transfer Switch		
100	U 3 / 4	INPVOLT_NET_10	Input Voltage	1
101	U 3 / 4	INPVOLT_NET_11	Input Voltage	1
102	U 3 / 4	INPVOLT_NET_12	Input Voltage	1
103	U 3 / 4	INFREQ_NET_1	Input Frequency	1
104	U 3 / 4	INPVOLT_NET_20	Input Voltage	1
105	U 3 / 4	INPVOLT_NET_21	Input Voltage	1
106	U 3 / 4	INPVOLT_NET_22	Input Voltage	1
107	U 3 / 4	INFREQ_NET_2	Input Frequency	1
108	U 3 / 4	STS_SYNCANGLE		1
109	U 3 / 4	STS_SYNDIFF		1
110	U 3 / 4	STS_S1BALANCE		1
111	U 3 / 4	STS_S2BALANCE		1
112	U 3 / 4	TEMPDEG	Temperature in degrees C°	1
113	U 3 / 4	OUTPUT_VOLT0	Output Voltage Phase 1	1
114	U 3 / 4	OUTPUT_VOLT1	Output Voltage Phase 2	1
115	U 3 / 4	OUTPUT_VOLT1	Output Voltage Phase 3	1
116	U 3 / 4	EX_OUT_CURR0		1
117	U 3 / 4	EX_OUT_CURR1		1
118	U 3 / 4	EX_OUT_CURR2		1
119	U 3 / 4	OUTPOWER0	Output Power Phase 1	1
120	U 3 / 4	OUTPOWER1	Output Power Phase 2	1
121	U 3 / 4	OUTPOWER2	Output Power Phase 3	1

Section	EverExceed Inverter			
100	U 3 / 4	TEMPDEG	Temperature in Degrees	1
101	U 3 / 4	INFREQ0	Line frequency	1
102	U 3 / 4	INVOLT0	Line voltage	1
103	U 3 / 4	OUTFREQ0	Frequency	1
104	U 3 / 4	OUTPUT_VOLT0	Output voltage	1
105	U 3 / 4	EX_OUT_VA0	Output power	1
106	U 3 / 4	STATUS	GENEREX UPS status (see below)	1
107	U 3 / 4	EX_EXTSTATUS	Alarm information	1
108	U 3 / 4	STATUS&1	Bypass mode, 1 = on, 0 = off	1
109	U 3 / 4	(STATUS&0x02)>>2	Output active, 1 = on, 0 = off	1
110	U 3 / 4	(STATUS&0x100)>>8	Overload, 1 = on, 0 = off	1
111	U 3 / 4	(STATUS&0x2000)>>13	General alarm, 1 = on, 0 = off	1

UPS Status EverExceed	Hex-Value	Dec-Value	Description
UPS_SB_BYPASS_MODE	0x0001	1	Bypass mode
UPS_SB_OUTPUT_ACT	0x0004	4	Output active
UPS_SB_OUTPUT_HIGH	0x0100	256	Overload
UPS_SB_UPS_FAILED	0x2000	8192	General alarm

Section	Gamatronic DC System			
100	U 3 / 4	TEMPDEG	Temperature in Degrees	1
101	U 3 / 4	INVOLT0	AC Input Voltage Phase 1	1
102	U 3 / 4	OUTPUT_VOLT0	DC Output Voltage	1
103	U 3 / 4	EX_OUT_CURR0	Total Output Current	1
104	U 3 / 4	EX_OUT_WATT0	Output Power in Watt	1
105	U 3 / 4	BATTVOLT	Battery Voltage	1
106	U 3 / 4	EX_BATT_CURRPOS	Battery Current	1
107	U 3 / 4	EX_NOM_VOLT	Nominal Voltage	1
108	U 3 / 4	EX_NOM_CURR	Nominal Current	1
109	U 3 / 4	STATUS	GENEREX UPS Status (see below)	1
110	U 3 / 4	(EX_EXTSTATUS & 0xffff0000)>>16	Bytes 98-99 (Device Status)	1
111	U 3 / 4	EX_EXTSTATUS & 0xffff	Bytes 100-101 (Device Status)	1
112	U 3 / 4	(STATUS&0x02)>>2	Output active, 1 = on, 0 = off	1
113	U 3 / 4	(STATUS&0x20)>>5	Overtemperature, 1 = on, 0 = off	1
114	U 3 / 4	(STATUS&0x40)>>6	Test active, 1 = on, 0 = off	1
115	U 3 / 4	(STATUS&0x100)>>8	Overload, 1 = on, 0 = off	1
116	U 3 / 4	(STATUS&0x2000)>>13	General alarm, 1 = on, 0 = off	1

UPS Status Gamatronic DC System	Hex-Value	Dec-Value	Description
UPS_SB_OUTPUT_ACT	0x0004	4	Output active
UPS_SB_OVER_TEMP	0x0020	32	Overtemperature
UPS_SB_TEST_ACT	0x0040	64	Test active
UPS_SB_OUTPUT_HIGH	0x0100	256	Overload
UPS_SB_UPS_FAILED	0x2000	8192	General alarm

Other OEM's	->See OEM MODBUS documentation	
--------------------	--	--

E.6. UPSMAN Status Bytes - Standard Device Status Bits

UPS Status	Hex-Value	Dec-Value	Description
UPS_SB_BYPASS_MODE	0x0001	1	power piped thru
UPS_SB_SHUTDOWN	0x0002	2	shutdown ups
UPS_SB_OUTPUT_ACT	0x0004	4	inverter on = UPS OK
UPS_SB_BACKUP_MODE	0x0008	8	battery power
UPS_SB_BATTERY_LOW	0x0010	16	low battery err
UPS_SB_OVER_TEMP	0x0020	32	over temp err
UPS_SB_TEST_ACT	0x0040	64	test in progress
UPS_SB_INPUT_HIGH	0x0080	128	over power err
UPS_SB_OUTPUT_HIGH	0x0100	256	over load err
UPS_SB_INVERTER_FAILURE	0x0200	512	Inverter error
UPS_SB_BATTERY_BAD	0x0400	1024	Battery error
UPS_SB_ECO_MODE	0x0800	2048	eco - bypass
UPS_SB_INVERTER_WARN	0x1000	4096	eco - bypass
UPS_SB_UPS_FAILED	0x2000	8192	prsrer flag
UPS_SB_COMM_LOST	0x4000	16384	for snmp
UPS_SB_DVG_ALARM	0x8000	32768	SiteManager/SiteMonitor

Example (decimal):

STATUS= „5” means UPS_SB_OUTPUT_ACT (4) + UPS_SB_BYPASS_MODE (1) are active
 != UPS on Bypass!

STATUS= „12” means UPS_SB_OUTPUT_ACT (4) + UPS_SB_BACKUP_MODE (8) are active
 != UPS Powerfail!

STATUS= „22” means UPS_SB_OUTPUT_ACT (4) + UPS_SB_BACKUP_MODE (8) +
 UPS_SB_BATTERY_LOW (10) are active != UPS Powerfail and Battery low!

STATUS= „4” means UPS_SB_OUTPUT_ACT (4) + no other alarms = UPS OK

E.7. Bus termination

It is necessary to set the last bus device on the RS-485 Bus jumper for the bus termination. (120 Ohm) The jumper is already set in newly delivered adapters. Please remove the 4 screws at the underside of the adapter in order to open the box. You will find the jumper J1 near the network connector, near the PCB shows a “+” symbol. (see fig.) Default is OFF = CS121 is NOT last device. To terminate the RS485 bus at your CS121, please close the Jumper.

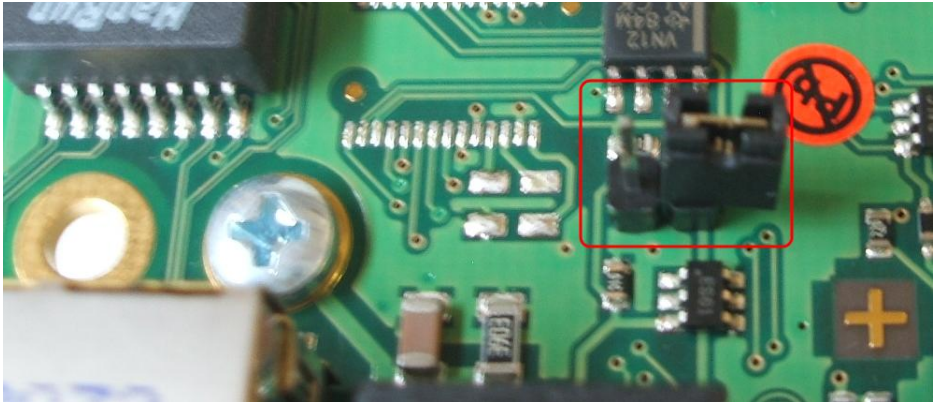

Figure 148: MODBUS - Jumper

E.8. Configuration

Please use Telnet (network connection) for the configuration with the default IP address 10.10.10.10. Put DIP switch 1 into the “OFF” position. If you have a RS-232/ RS-485 converter available you can also use a HyperTerminal via COM2 with both DIP switches in the “OFF” position.



Figure 149: MODBUS – CS121 COM2 Settings

E.9. TCP/IP - UDP Ports

The following are ports of the CS121 SNMP Adapter. These are the ports that have to be made available in the Firewall in order to use all of the CS121 functions:

Echo	7/tcp
echo	7/udp
WOL	9/udp
ftp-data	20/tcp
ftp	21/tcp
telnet	23/tcp
smtp	25/tcp
http	80/tcp
snmp	161/udp
snmptrap	162/udp
time (rfc868)	37/tcp
time (snmp)	123/tcp
rccmd	6003
Upsmon	5769
Modbus over IP	502/tcp
Update flash	4000/udp

The UPSMON port 5769 is required for the following:

- UPSMON Windows
- RCCMD and UNMS II alive check
- Port forwarding (unblocking of several CS121 into the network via own ports into other networks)
- Support of all other commands and functions via UPSTCP

E.10. MODBUS Cables

The following cable (Cable 112) is used for connecting the Schneider Electric TSX SCY CM6030 MODBUS device and the CS121 MODBUS adapter.



Figure 150: MODBUS - Cable 112

NOTE: it is very important that the Shield is connected to the MINI 8 housing and to the MODBUS requesting device common ground!

F. Available Variables of the CS121



Note: Not all variables are supported from all UPS-models. Please try the use of the variable to see, whether your UPS supports the variable or not.

Variable	Meaning
OUTPUT_VOLT	Output voltage - only supported from specified USV manufactures
OUTPUT_CURRENT	Output currency
SECSONBATT	Seconds, since the event power outage has been released
STATUS	Actual UPS state
INVOLT0	Input voltage, phase 1
INVOLT1	Input voltage, phase 2
INVOLT2	Input voltage, phase 3
INCURR	Input currency
BATTVOLT	Battery voltage
TEMPDEG	Ambient or operating temperature – depends on the UPS-Model
AUTONOMTIME	Power-on time left over under actual charge
BATTCAP	Capacity of the battery in percent
OUTPOWER0	Load in percent, phase 1
OUTPOWER1	Load in percent, phase 2
OUTPOWER2	Load in percent, phase 3
INFREQ0	Input frequency, phase 1

INFREQ1	Input frequency, phase 2
INFREQ2	Input frequency, phase 3
OUTFREQ0	Output frequency, phase 1
OUTFREQ1	Output frequency, phase 2
OUTFREQ2	Output frequency, phase 3
CONNECT	ID of the used UPS protocol
CABLE	ID of the used cable type
POWER	Configurated UPS Power
LOAD	Configurated Load
HOLDTIME	Configurated hold time
RECHARGETIME	Configurated time for a complete battery charging
MODEL	UPS model name
TIMEREMAIN	Resttime (AUTONOMTIME-POWERREMAIN)
LOCALTIME	Local timestamp
OUTPHASES	Output phase
INPHASES	Input phase
LOCATION	UPS-Adapter location
DATE	Date
TIME	Time
ATTACHED_DEVICES	Attached devices
BATTINSTDATE	Battery installation date
AGENTSOFTRREV	Firmware version
MANUFACTURER	Manufacturer
TEMP1, ..., TEMP8	Actual measurement for sensors 1-8, used for SensorMan settings only
TEMP1LOCATION, ..., TEMP8LOCATION	Configurated sensor 1-8 location
TEMP1UNIT, ..., TEMP8UNIT	Configurated sensor 1-8 unit
CUSTOM1TEXT, ..., CUSTOM6TEXT	Configurated Custom Text 1-6

G. Pin layout of Input-sockets of the SENSORMANAGER unit

INPUT 1:

- Pin 1 Input Voltage 9-24Volt +
- Pin 2 Analog Channel 1 (0-10V+)
- Pin 3 Analog Channel 5 (0-10V+)
- Pin 4 Ground

Pin 5 OUTPUT: Open collector OUT 9-24 V, max. 30mA

Pin 6 INPUT: Digital Input 9-24V

INPUT 2:

Pin 1 Input Voltage 9-24Volt +

Pin 2 Analog Channel 2 (0-10V+)

Pin 3 Analog Channel 6 (0-10V+)

Pin 4 Ground

Pin 5 OUTPUT: Open collector OUT 9-24 V, max. 30mA

Pin 6 INPUT: Digital Input 9-24V

INPUT 3:

Pin 1 Input Voltage 9-24Volt +

Pin 2 Analog Channel 3 (0-10V+)

Pin 3 Analog Channel 7 (0-10V+)

Pin 4 Ground

Pin 5 OUTPUT: Open collector OUT 9-24 V, max. 30mA

Pin 6 INPUT: Digital Input 9-24V

INPUT 4:

Pin 1 Input Voltage 9-24 Volt +

Pin 2 Analog Channel 4 (0-10V+)

Pin 3 Analog Channel 8 (0-10V+)

Pin 4 Ground

Pin 5 OUTPUT: Open collector OUT 9-24 V, max. 30mA

Pin 6 INPUT: Digital Input 9-24

H. Events/Alarms of the CS121 – Description of the alarms

The Events/Alarms are different from UPS to UPS, depending on the UPS manufacturer. We are describing in the following example the Events/Alarms of a NEWAVE UPS, which are similar to most of the UPS. Anyway all alarms, which are not POWERFAIL, BATTERY LOW, SYSTEM SHUTDOWN, UPSMAN STARTED and AUX, you should advice your UPS manufacturer, because an UPS hardware failure might be present! The mentioned alarms are universal. The POWERFAIL and BATTERY LOW alarm require a reaction, e. g. the configuration of shutdowns of clients via RCCMD.

Event	Description
Powerfail	UPS is on battery and the autonomy time decreases. ADVICE: The RCCMD shutdowns will be set into this alarm, to send shutdown signals to the clients, if the powerfail will last longer!
Power Restored	Power supply restored
System Shutdown	This event is TRUE, if the remaining time is reached or rather undershot. That means the autonomy time is only available for seconds, the UPS shutdown is pending.
UPSMAN Started	UPS service is started into the CS121. This event is always true, if the CS121 is running and therefore ideal for permanent recurrent jobs suitable like the forwarding of emails always after restart of the UPS or to produce log file entries steady.
UPS Connection Lost	UPS RS232 communication lost, CS121 tries to restore the connection.

UPS Connection Restored	UPS RS232 communication restored
Battery Low	The autonomy of the battery has reached the defined threshold "Battery Low". The UPS shutdown is pending. ADVICE: The RCCMD shutdowns will be set into this event too, but without delay! (Emergency shutdown, if batteries are to weak)
Output Breaker Open	Output breaker open. UPS is isolated from load. No supply of the consumers.
Output Breaker Closed	Output breaker closed. Load will be supplied.
Maintenance Breaker Closed	Maintenance breaker closed (active). Load will be supplied through the grid directly.
Maintenance Breaker Open	Maintenance breaker open (inactive). Load will be supplied via the UPS. Regular UPS protected operation.
Inverter Breaker Open	Inverter breaker open. Load is not UPS protected!
Inverter Breaker Closed	Inverter breaker closed. Load will be supplied via the inverter. Normal condition.
Battery Breaker Open	Battery breaker open. No battery buffering active!
Battery Breaker Closed	Battery breaker closed. OK, normal condition.
UPS Off	UPS off
UPS On	UPS on
New Alarm	New alarm, buzzer was activated.
Buzzer Off	Buzzer off
General Alarm	An alarm has occurred. Alarm LED at the UPS is flashing.
General Alarm Off	No more alarm is active. Alarm LED at the UPS is off.
Overtemperature	Overtemperature of the UPS
Temperature Ok	Temperature of the UPS is back in normal range.
Output Bad	UPS output failure (e. g. voltage, frequency)
Output Okay	UPS output OK
Overload	UPS overload, reduce load otherwise the UPS shutdown is pending
No More Overload	No more overload
Bypass Bad	Bypass failure at input (e. g. voltage, frequency)
Bypass Ok	Bypass Ok
UPS Shutdown Canceled	UPS shutdown canceled
UPS Shutdown	UPS shutdown initiated
Charger Fault	Charger fault

Charger Ok	Charger Ok
System Off	UPS output will be switched off or rather is off
System Off Canceled	UPS output switching off canceled
Bypass On	Bypass on
Bypass Off	Bypass off
Battery Depleted	Battery depleted
Input Bad	Input bad, alarm will be triggered with the powerfail event
Mains Input Okay	Power restored at the input
Fan Failure	UPS fan failure
Fan Ok	UPS fan OK
Awaiting Power	Awaiting power prior of automatic start of UPS
Shutdown Pending	UPS shutdown/switching off is pending
Shutdown Imminent	UPS shutdown/switching off is imminent
Unit Powerfail	Powerfail at an UPS module
Unit Power Restored	Power restored at an UPS module
Redundancy Lost	UPS redundancy lost, load to high or UPS modules are not at hand
Inverter Failure	Inverter failure
Emergency Power Off	Emergency power off, UPS was switched off
Synchronization Error	Synchronization error between the parallel modules or for the feeding, e. g. power supply of a diesel generator
ECO Mode On	ECO mode on, load is on bypass
ECO Mode Off	ECO mode off, load is on rectifier
Battery Weak	Battery weak
Battery Need Replacement	Battery need replacement, please restart the UPS after replacement
Battery Ok	Battery Ok
Rectifier On	Rectifier on
Rectifier Off	Rectifier off
Inverter Off	Inverter off
Inverter On	Inverter on
Booster On	Voltage booster of battery is on
Booster Off	Voltage booster of battery is off
Battery Discharging	Battery discharging
Battery Charging	Battery charging
Load Is Supplied	Load is supplied, normal condition

Fuses Failure	Fuses failure
Fuses Ok	Fuses Ok
Battery Grounding Error	Battery grounding error
Generator On	Generator on
Generator Off	Generator off
Output Normal	Output normal, normal condition
Redundancy Ok	Redundancy is at hand
AUX Port 1 High	AUX port 1 opened
AUX Port 2 High	AUX port 2 opened
AUX Port 3 High	AUX port 3 opened
AUX Port 4 High	AUX port 4 opened
AUX Port 1 Low	AUX port 1 closed
AUX Port 2 Low	AUX port 2 closed
AUX Port 3 Low	AUX port 3 closed
AUX Port 4 Low	AUX port 4 closed

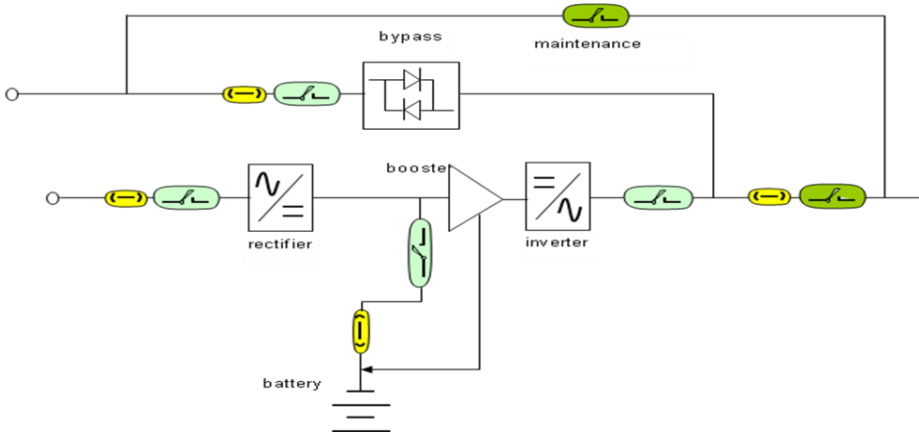

Schematic drawing of an UPS, e. g. NEWAVE

Yellow = Fuse

Blue = Automatic breaker

Green = Manual Breaker

I. Description of the alarms for single-phase UPS

Event	Description

Powerfail	UPS is on battery and the autonomy time decreases. ADVICE: The RCCMD shutdowns will be set into this alarm, to send shutdown signals to the clients, if the powerfail will last longer!
Power restored	Power supply restored
System Shutdown	This event is TRUE, if the remaining time is reached or rather undershot. That means the autonomy time is only available for seconds, the UPS shutdown is pending.
UPSMAN started	UPS service is started into the CS121. This event is always true, if the CS121 is running and therefore ideal for permanent recurrent jobs suitable like the forwarding of emails always after restart of the UPS or to produce log file entries steady.
UPS connection lost	UPS RS232 communication lost, CS121 tries to restore the connection.
UPS connection restored	UPS RS232 communication restored
UPS Battery Old	UPS batteries too old, call UPS service
Overload	UPS overload, reduce load otherwise the UPS shutdown is pending
Load Normal	No more overload
Overtemperature	Overtemperature of the UPS
Temperature Normal	Temperature of the UPS is back in normal range
Bypass on	Bypass on
Bypass off	Bypass off
Battery low	The autonomy of the battery has reached the defined threshold "Battery Low". The UPS shutdown is pending. ADVICE: The RCCMD shutdowns will be set into this event too, but without delay! (Emergency shutdown, if batteries are to weak)
UPS battery bad	Battery in bad condition
Scheduler Shutdown	This event got no relevance and will be removed in the future CS121 firmware
Input bad	Input bad, alarm will be triggered with the powerfail event
Load >80%	Load is over 80%
Load >90%	Load is over 90%
General Alarm	An alarm has occurred. Alarm LED at the UPS is flashing
General Alarm canceled	No more alarm is active. Alarm LED at the UPS is off
Manual Bypass on	Manual Bypass on
Manual Bypass off	Manual Bypass off
Charger fault	Charger fault
AUX Port 1 High	AUX port 1 opened
AUX Port 2 High	AUX port 2 opened
AUX Port 3 High	AUX port 3 opened

AUX Port 4 High	AUX port 4 opened
AUX Port 1 Low	AUX port 1 closed
AUX Port 2 Low	AUX port 2 closed
AUX Port 3 Low	AUX port 3 closed
AUX Port 4 Low	AUX port 4 closed

J. Configuration of Microsoft SCOM 2007 as CS121 Trap Receiver (Monitor)

In this section we will configure Microsoft Operations Manager 2007 (SCOM/OpsMgr) as an SNMP Trap receiver, discover SNMP-enabled cs121 network devices, and configure an alert-generating SNMP-trap-based monitor to raise alerts when specific traps are received from cs121 devices.

Installation of the SNMP service (on Windows Server 2003)

- In the Control Panel, select Add Remove Programs
- Click on Add/Remove Windows Components
- Scroll down and select Management and Monitoring Tools, click Details.
- Click on the checkboxes for Simple Network Management Protocol (and optionally WMI SNMP Provider) and click OK.
- Click Next and click Finish.

Configuration of the SNMP service (on Windows Server 2003)

- Close Add or Remove Programs.
- Click Start, Run, type services.msc, and then click Enter.
- Scroll down and select SNMP Service. Right click the service and select Properties.

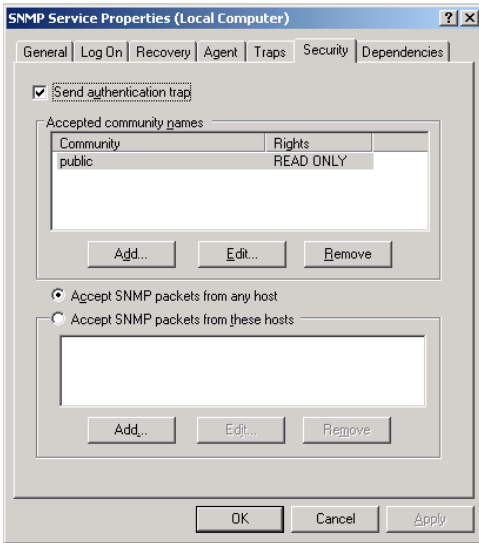

Figure 151: SNMP Service Properties

- Select the Security tab.

- Check the Send Authentication Traps checkbox. In the Accepted Community Names list, type “public” and click the Add to list button. Rights should be set to READ CREATE.
- Select the Accept SNMP packets from these hosts radio button. Use the add button to add the IP addresses of the managed devices that will forward SNMP traps to the OpsMgr server. Alternatively, you could select the Accept SNMP packets from any host option.
- Restart the SNMP Service.

IMPORTANT: SNMP community strings are case sensitive!

Activate the SNMP Trap Service (on Windows Server 2003)

- In the Services Panel, select the SNMP Trap Service
- In the SNMP Trap Service properties dialog select « Startup type : Automatic », then click the « Start » button to start this service now.

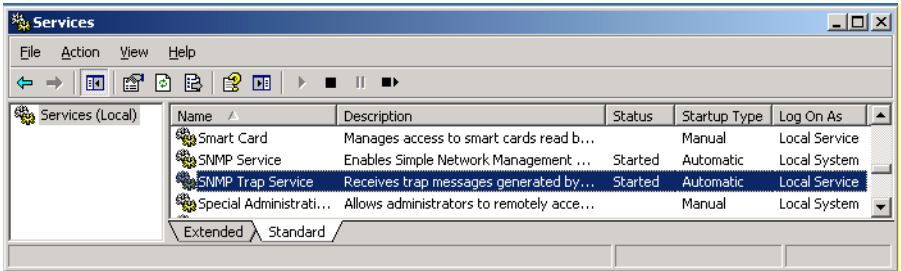

Figure 152: SNMP Trap Service

Configuration of OpsMgr as SNMP trap receiver

The cs121 device must be configured to accept SNMP requests from the OpsMgr Server. You must also configure the cs121 device to use the same SNMP community string you configured in the Accepted community names in the SNMP Service properties on your OpsMgr Server. Please take a look at the cs121 manual for the details of this configuration step...

Configuration of one or more alert-generating SNMP-trap-based Monitors

- In the Administration space, create a unsealed management pack to store your SNMP-based monitoring rules.

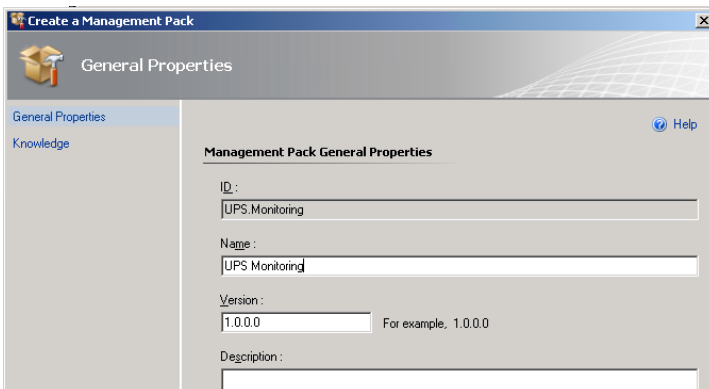

Figure 153: General Properties

- In the Operations console (Authoring space), start the Create a Monitor Wizard.

- On the Select a Monitor Type page, do the following:
- Expand SNMP → Trap Based Detection → Simple Trap Detection → Event Monitor – Single Event and Single Event.
- Select your unsealed management pack from the list. Click Next.

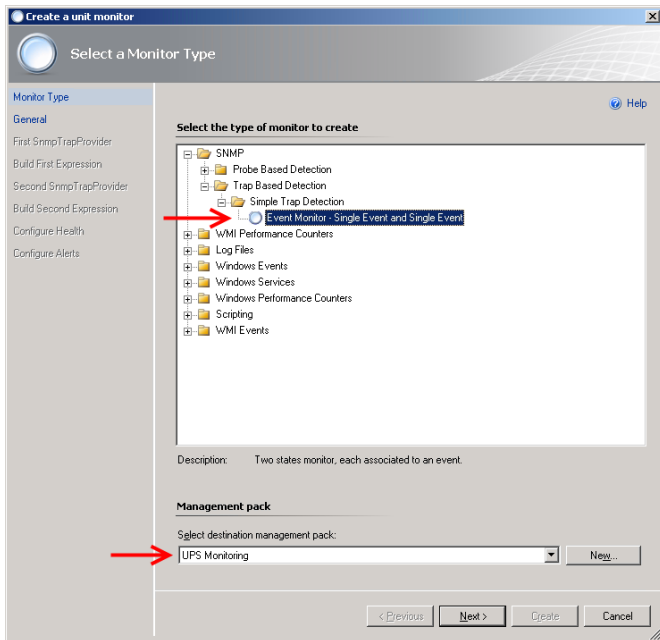

Figure 154: Select a Monitor Type

- On the General Properties page, do the following:
- Type the Monitor name, such as UPS On Battery Monitor. Optionally, type a Description for the monitor.
- Click Select, select View all targets, click a target, such as SNMP Network Device, and then click OK.
- Leave Monitor is enabled selected to have the monitor take affect at the completion of the wizard, or clear the check box to enable the monitor at a later time, and then click Next.

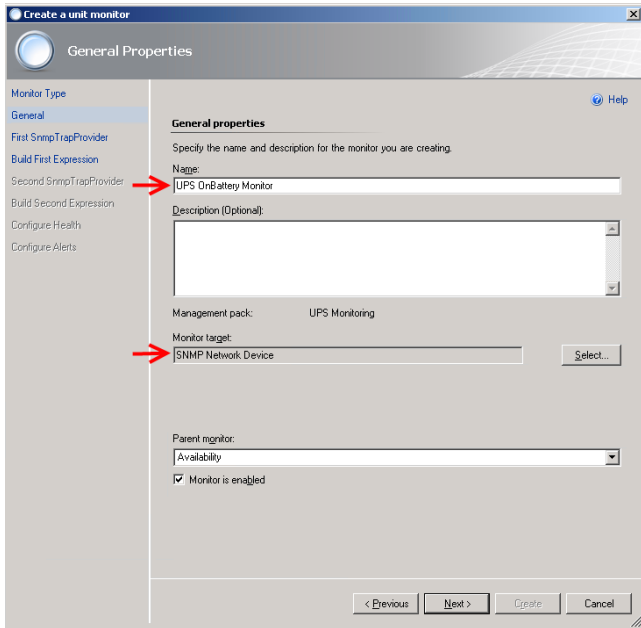

Figure 155: General Properties

- On the Configure the trap OIDs to collect page for the First SNMP TrapProvider, leave Use discovery community string selected.
- Click to place the cursor in the Object Identifier Properties section and type the first object identifier (OID) that you want to monitor: 1.3.6.1.2.1.33.2.3 (upsTrapAlarmEntryAdded). Then click Next.

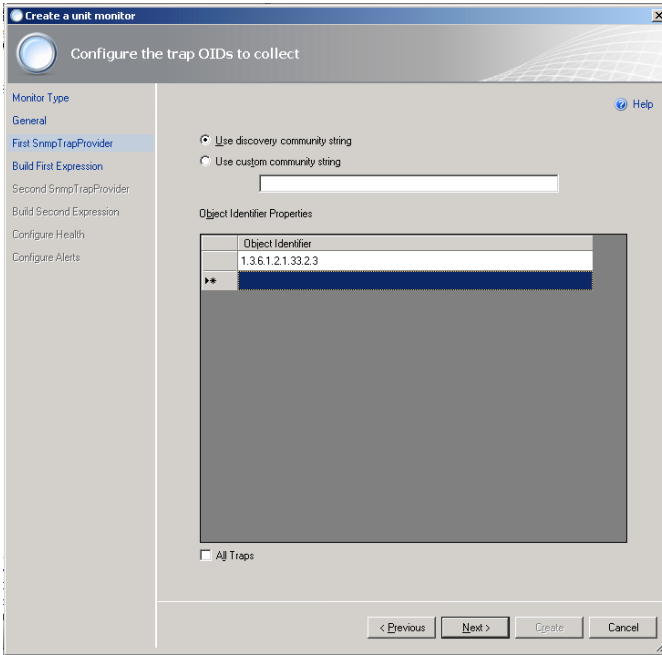

Figure 156: Configure the trap OIDs to collect

- On the Build Event Expression page, click to place the cursor in the Parameter Name section and type the trap parameter variable that you want to use here: /DataItem/SnmpVarBinds/SnmpVarBind[2]/Value
- Why did we use SnmpVarBind[2] in our expression? Because the traps second contains the OID of the traps UPS alarm (Object upsAlarmDescr of the trap).
- Click to place the cursor in the Operator section and select Equals.
- Click to place the cursor in the Value section and type the value to match here: 1.3.6.1.2.1.33.1.6.3.2 (The 1.3.6.1.2.1.33.1.6.3.2 is the well known alarm OID for upsAlarmOnBattery).

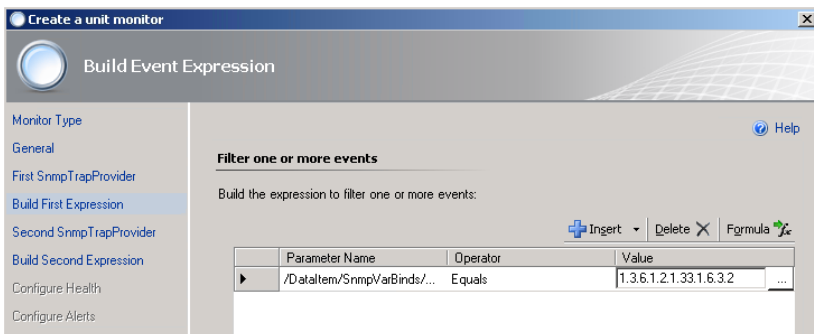

Figure 157: Build Event Expression

- Then click Next.
- On the Configure the trap OIDs to collect page for the Second SNMP TrapProvider, leave Use discovery community string selected.
- Click to place the cursor in the Object Identifier Properties section and type the first object identifier (OID) that you want to monitor: 1.3.6.1.2.1.33.2.4 (upsTrapAlarmEntryRemoved). Then click Next.

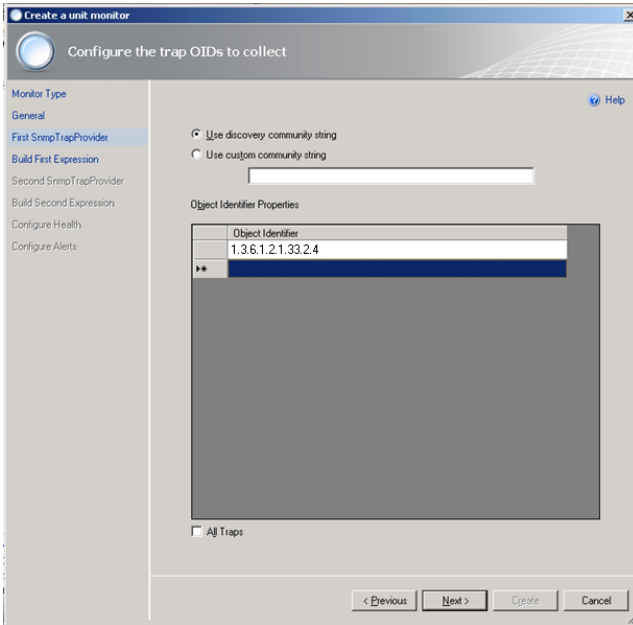

Figure 158: Configure the trap OIDs to collect

- On the Build Event Expression page, click to place the cursor in the Parameter Name section and type the trap parameter variable that you want to use here: /DataItem/SnmpVarBinds/SnmpVarBind[2]/Value
- Why did we use SnmpVarBind[2] in our expression? Because the traps second contains the OID of the traps UPS alarm (Object upsAlarmDescr of the trap).
- Click to place the cursor in the Operator section and select Equals.
- Click to place the cursor in the Value section and type the value to match here: 1.3.6.1.2.1.33.1.6.3.2 (The 1.3.6.1.2.1.33.1.6.3.2 is the well known alarm OID for upsAlarmOnBattery).

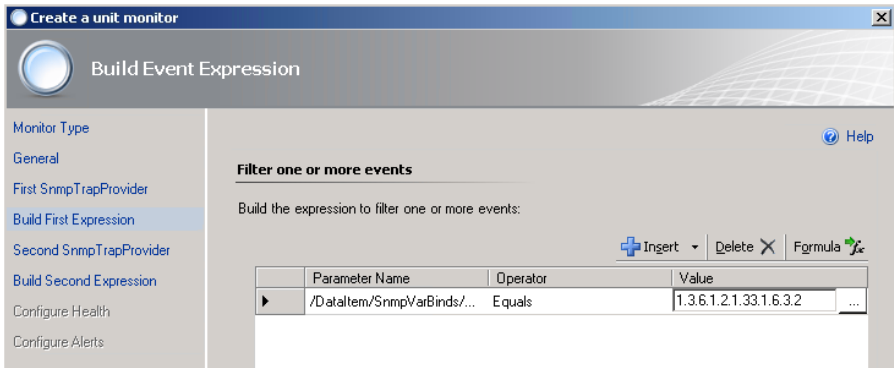

Figure 159: Build Event Expression

- Then click Next.
- On the Configure Health page, select Critical for the Health State of Monitor Condition First Event Raised. Then click Next.

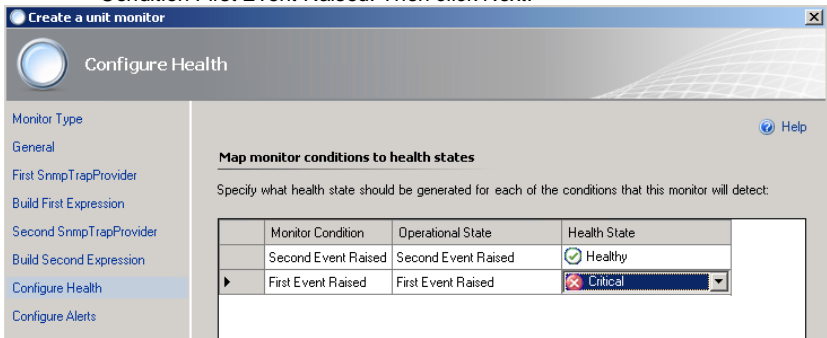

Figure 160: Configure Health

- On the Configure Alerts page, set the properties of the alert, for example:
- Type the Name for the alert, such as UPS OnBattery Alert.
- Optionally, type the Alert description. You can also click the (...) button and select Target and Data variables to include in the description, such as Device Name.
- Select a Priority from the list, such as High.
- Select a Severity from the list, such as Critical.
- Click Create

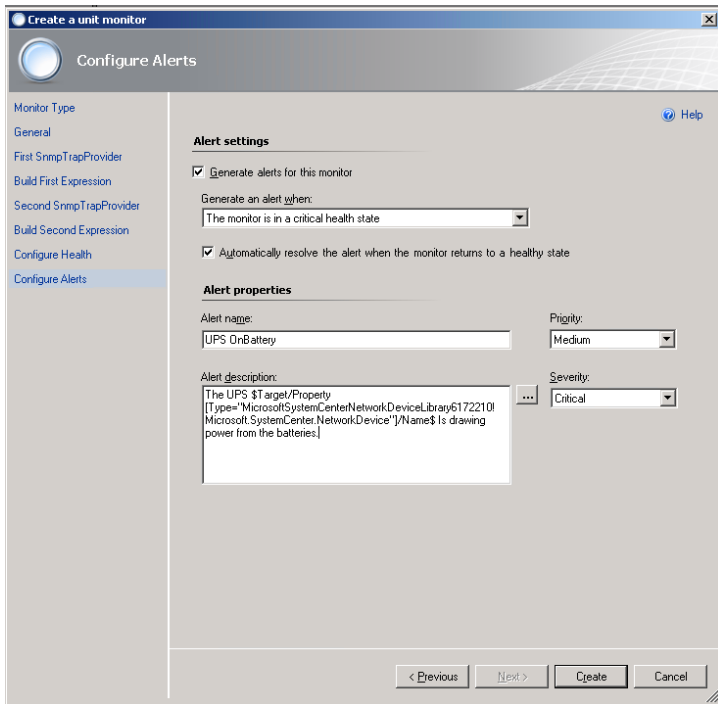

Figure 161: Configure Alerts

Discover your SNMP enabled CS121 devices in OpsMgr

- In the Administration space, right click and launch the Discovery Wizard.
- On the What would you like to manage page, select Network Devices. Then click Next.192.168
- On the Discovery Method page, enter the Start and End of the IP address range that you want to scan.
- Type the SNMP community of the objects that you want to manage.
- Select the Management Server that should receive the cs121 traps.
- Click Discover to display the Discovery Progress page.

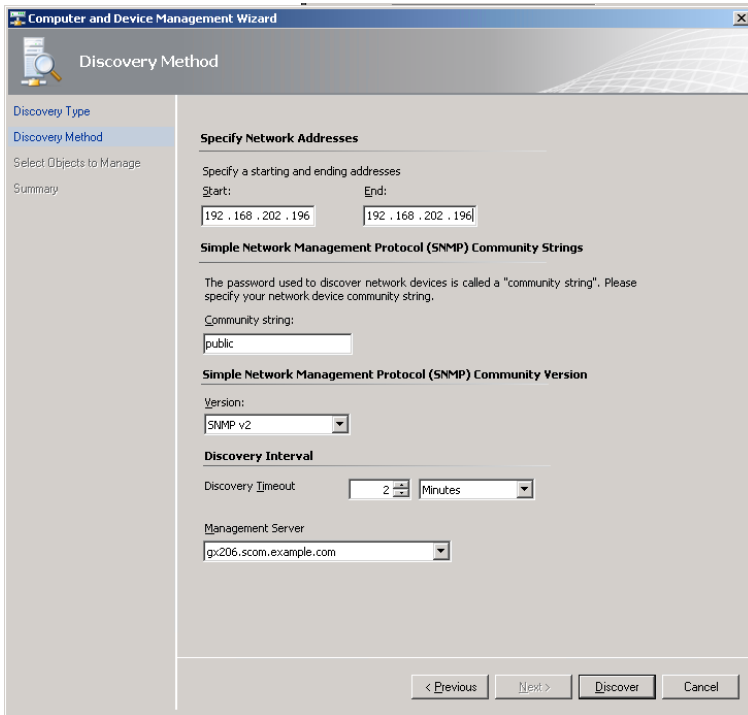

Figure 162: Discovery Method

Discovery for even a single device will run for a couple of minutes by default. If you specify an IP range, it will take a little longer.

- On the Select Objects to Manage page, select the devices desired for management.
- On the Summary page, click Finish. The objects will display in the Network Devices node of the Operations Console Administration space.

At this point, SNMP-enabled device availability monitoring will start automatically. Any traps (of kind upsAlarmOnBattery) received from the cs121 target devices will be raised as alerts in the Operations console.

K. DHCP Configuration via Telnet

Establish a connection to the CS121 via telnet. Select the menu 1 (IP Address, Gateway Address) and enter the menu 5. (Set DHCP Server).

```
ca Telnet 192.168.222.201
sysContact:
sysName:      CS-121
sysLocation:
Attached Devices: UPS protected devices

COMMANDS:
[ 1] Set IP address
[ 2] Set gateway address
[ 3] Set subnet mask
[ 4] Set DNS server
[ 5] Set DHCP server
[ 6] Set sysContact
[ 7] Set sysName
[ 8] Set sysLocation
[ 9] Set UPS Attached Devices. <ex. 1 PC, 1 Printer>
[ 0] Back to Main Menu

EXAMPLES:
to set the IP address to 128.100.90.57:
=> 1 128.100.90.57
to disable DHCP:
=> 5 0.0.0.0
to accept DHCP offers from any server:
=> 5 255.255.255.255

Enter Command =>
```

Figure 163: Telnet – DHCP Settings

Please enter the following:

```
5 255.255.255.255
```

You can enter the accordant IP address of the DHCP server, if you know it. If you want to disable DHCP, please enter the following:

```
5 0.0.0.0
```

Exit the menu with “0” and “S”. The CS121 will work with the desired function after the reboot.

L. RARITAN Dominion PDU Configuration

In the following, we will describe, how a RARITAN PDU Type Dominion can be controlled through any RCCMD client or any CS121 or any other RCCMD compatible device :

1. Install a RCCMD client on a Windows OS and copy/create a file, like the following, into the RCCMD directory (default C:\Program Files\RCCMD) and use a SNMPwalk tool from an open source with the mandatory distribution txt-file « Copying.txt ». This file is included for legal reasons (Open Source).

```

@echo off
set PX_OID=1.3.6.1.4.1.13742.4.1.2.2.1.3.

if x%1==x goto paramerror
if x%2==x goto paramerror
if x%3==x goto paramerror
if x%4==x goto paramerror

snmpset -v 2c -c %2 %1 %PX_OID%3 i %4
goto end

:paramerror
echo.
echo missing parameter!
echo.
echo Usage: pxout.bat ip community port value
echo ip:      address of the PX device
echo community: SNMP community string
echo port:    1-12
echo value:   0 or 1

:end

```

Figure 164: „pxout.bat“

The command is called « pxout.bat » and expect 4 parameters :

- IP address or hostname of the Raritan device
- SNMP community string (the one for write access)
- Outlet number (1 to 12)
- 0 = off, 1 = on

2. The batch file “pxout.bat” accepts now several parameters from incoming RCCMD executes and translates these into SNMP set commands for the Raritan.

The “pxout.bat” accepts the following command syntax:

“pxout.bat <IP address> <community> <Outlet> <on/off>”

- **IP address:** This is the IP address of the Raritan
- **Community:** This is the community string for “write access”, configured at the Raritan or SNMP set commands, default is “public”.
- **Outlet:** This is the number of the Raritan Outlet 1 to 12, which you want to switch.
- **On/Off:** This is the signal you want to transmit, where “0” is off and “1” is on.
- **Example:** “pxout.bat 192.168.200.11 public 0” This example will switch the Raritan with the IP address 192.168.200.11, the outlet 4 to off!

If this works manually from your Windows RCCMD computer, than you can go ahead with step 3.

3. Now you have to select the desired CS121 event and add a RCCMD command, which will be send to the Windows computer, where RCCMD is running and the “pxout.bat” file is located.

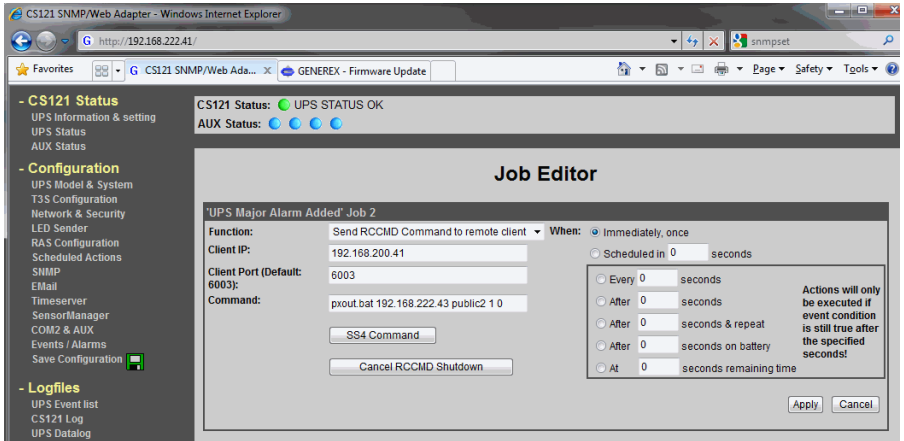

Figure 165: CS121 Configuration for such a relay command

The target of the RCCMD command is the Windows computer with RCCMD and the „pxout.bat“ with the IP address 192.168.200.41. If the event „UPS Major Alarm Added“ will occur, this Job will execute the command „pxout.bat 192.168.222.43 public2 1 0“ to switch off the socket number 1 at the Raritan with the IP address 192.168.222.43 immediately.

Tip: You should stop RCCMD running in the background on this Windows computer, so you will better see, whats going on. Stop the RCCMD service, than open a command line into the RCCMD folder and start „rccmd.exe –debug“. Now the software will run in the foreground and you can watch the communication.

4. The Raritan with firmware 1.4.1 is unfortunately buggy. Here the workaround: The default community strings for the Raritan are identically set for „read“ and „write“ to „public“, but this configuration is invalid! It must be different!

Solution: Stop the SNMP Agent at the Raritan, change the community for „write“ to any other than „public“ and restart it!

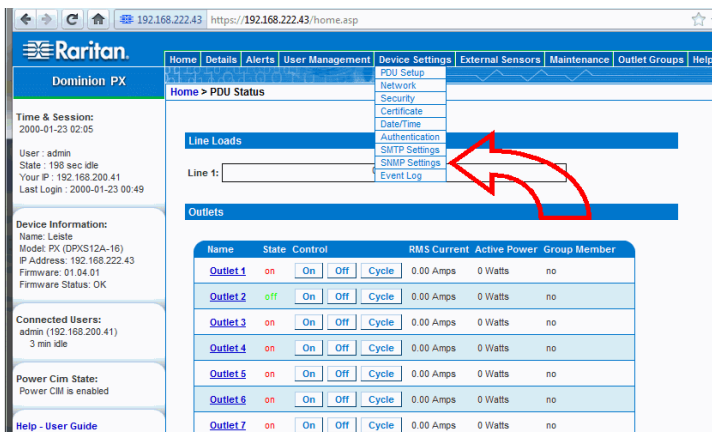



Figure 166: Raritan Device Settings

The default Raritan user is „admin“, password is „nimda“.

 Attention! This does not work with MS Internet Explorer! Use any other web-browser, e. g. Mozilla Firefox.

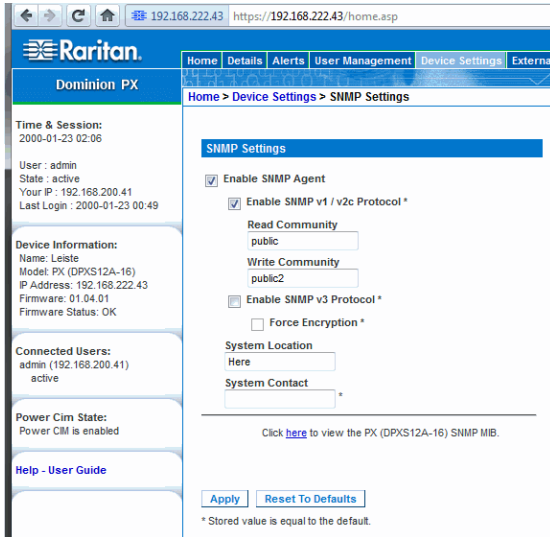

Figure 167: Raritan SNMP Settings

Click on „Stop“, change the configuration on „Write Community“, e. g. to „public2“ and restart.

Table of figures

Figure 1:	CS121 into a Network Environment	11
Figure 2:	Connections of the CS121	12
Figure 3:	CS121L (left) in configuration mode (IP 10.10.10.10) and CS121SC (right) in normal mode.....	13
Figure 4:	Connection PC-Switch/Hub and CS121 (2) Connection PC-Cross Cable/Network Cable and CS121	16
Figure 5:	HTTP - Administrator login.....	17
Figure 6:	HTTP - UPS Model & System Settings	18
Figure 7:	HTTP - Network & Security Settings	18
Figure 8:	Telnet - Main Menu	19
Figure 9:	Telnet - IP Settings.....	19
Figure 10:	Telnet - UPS Settings.....	20
Figure 11:	HTTP – Adapter reboot dialog	21
Figure 12:	HTTP – System & Network Status.....	22
Figure 13:	HTTP – UPS Status	22
Figure 14:	HTTP - UPS Functions for AEG UPS	22
Figure 15:	HTTP - AUX & SensorMan Status.....	23
Figure 16:	HTTP - UPS Model & System.....	24
Figure 17:	HTTP - Network & Security Settings	24
Figure 18:	HTTP - Network & Security DHCP Settings	26
Figure 19:	HTTP - Network & Security ICMP Check	26
Figure 20:	HTTP – Network & Security Hide HTTP Links	27
Figure 21:	HTTP – Network & Security ARP Settings	27
Figure 22:	HTTP - Email Settings.....	28
Figure 23:	CS121 Email Settings	29
Figure 24:	UNMS II screen with timestamp of the latest measuring values update	30
Figure 25:	UNMS Email Trap Settings	30
Figure 26:	HTTP - Timeserver Settings	31
Figure 27:	Language Configuration	32
Figure 28:	IE8 Internet Options – Languages.....	33
Figure 29:	HTTP - Event Configuration with tool tip	33
Figure 30:	HTTP - Event Editor	34
Figure 31:	HTTP – Event Editor, Example of a Shutdown-Configuration	34
Figure 32:	HTTP – Threshold event.....	35
Figure 33:	HTTP – COM2 Threshold events SM_T_COM.....	35
Figure 34:	HTTP - Job Editor: Logfile entry	35
Figure 35:	HTTP - Job Editor: Email-Job	36
Figure 36:	HTTP - Job Editor: Continuous event job.....	36
Figure 37:	HTTP - Job Editor: Switch AUX-Port	37
Figure 38:	HTTP – SNMP Settings	38
Figure 39:	HTTP – SNMP Algorithms	39
Figure 40:	HTTP - COM2 Mode overview.....	40
Figure 41:	Pipe Thru Installation.....	41
Figure 42:	HTTP - COM2 & AUX with TEMPMAN	42
Figure 43:	HTTP – Sensor Manager Settings.....	44
Figure 44:	HTTP - RAS Manager Settings.....	44
Figure 45:	HTTP – Scheduled Actions.....	45
Figure 46:	HTTP – CS121 DataLog	48
Figure 47:	HTTP – CS121 ExternalDeviceLog	48
Figure 48:	HTTP – CS121 UPS Events	49
Figure 49:	HTTP - Job Editor: RCCMD Trap, Event « Power restored »	51
Figure 50:	HTTP - Job Editor: RCCMD TRAP	51
Figure 51:	HTTP - Job Editor: RCCMD Shutdown	52
Figure 52:	HTTP – Event Configuration	53
Figure 53:	HTTP – Event Editor	53
Figure 54:	HTTP - Job Editor.....	53

Figure 55:	HTTP - Job Editor / Function.....	54
Figure 56:	HTTP – CS121 Configuration Manager.....	55
Figure 57:	HTTP – Event Editor / Test	55
Figure 58:	HTTP – Job Test Page.....	55
Figure 59:	HTTP – AlarmLog.....	55
Figure 60:	HTTP – Job Editor RCCMD WAKEUP	56
Figure 61:	HTTP – Job Editor RCCMD WAKEUP	56
Figure 62:	HTTP - Job Editor: RCCMD execute/command.....	57
Figure 63:	HTTP – Enable RCCMD Listener	58
Figure 64:	HTTP - Job Editor: RCCMD-Command.....	58
Figure 65:	HTTP - Job Editor: Shutdown UPS-Job	59
Figure 66:	HTTP - Job Editor: Wake On LAN	60
Figure 67:	HTTP – Scheduled Actions	60
Figure 68:	HTTP – Status Page Socomec Transfer Switch	61
Figure 69:	HTTP – Status Page Eaton Transfer Switch	61
Figure 70:	HTTP - Firmware Update Page	62
Figure 71:	CS121-Configuration Manager	63
Figure 72:	CS121-FTP Access.....	64
Figure 73:	CS121-FTP Context Menu.....	64
Figure 74:	CS121-FTP Folders.....	64
Figure 75:	CS121-FTP Upsman.cfg.....	65
Figure 76:	CS121-FTP File Replacement.....	65
Figure 77:	CS121-Reboot	66
Figure 78:	RCCMD - Overview.....	66
Figure 79:	RCCMD SSL Settings	67
Figure 80:	Timeserver Settings.....	67
Figure 81:	Settings Confirmation	68
Figure 82:	jChart Display of the CS121 Data Log.....	69
Figure 83:	jChart Display of a Measurement Value	69
Figure 84:	jChart Display of the Loads	70
Figure 85:	jChart – Zoom-In of an Area.....	70
Figure 86:	jChart – Colour Selection	71
Figure 87:	gchart plug-in for the internet explorer.....	71
Figure 88:	Internet Options of the internet explorer	72
Figure 89:	Security Settings.....	73
Figure 90:	SideSwitch4 and SS4 AUX	74
Figure 91:	CS121-Installation with SideSwitch4	74
Figure 92:	Exchange COM Ports 1 & 2 for SS4.....	75
Figure 93:	The Sensor SM_T_COM.....	76
Figure 94:	CS121-Installation with temperature SM_T_COM	76
Figure 95:	CS121- SM_T_COM Settings	77
Figure 96:	CS121- SM_T_COM Functions	77
Figure 97:	CS121-Configuration Threshold Events of analogue Inputs.....	78
Figure 98:	CS121-Configuration Threshold Event for SM_analogue 1.....	78
Figure 99:	Sensor Manager (SensorMan).....	79
Figure 100:	CS121-Installation with SENSORMANAGER	80
Figure 101:	SENSORMANAGER II Settings.....	81
Figure 102:	SENSORMANAGER II LEDs	81
Figure 103:	SENSORMANAGER II Status Site	83
Figure 104:	SENSORMANAGER II Configuration Analog Inputs	84
Figure 105:	SENSORMANAGER II Configuration Outlets	84
Figure 106:	Alarm matrix – Marker configuration.....	85
Figure 107:	Alarm Matrix – Switching of relay outputs	85
Figure 108:	Alarm Matrix – Switching of relay outputs	86
Figure 109:	RASMANAGER network integration.....	86
Figure 110:	PIN Adjustment Adapter-Connector GSM_A	87
Figure 111:	Mini8-DSUB9 Cable Cross-Section.....	87

Figure 112:	COM2 Mode: GSM Modem	87
Figure 113:	Configuration of the Function	88
Figure 114:	Siemens GSM TMA T35i Modem	88
Figure 115:	GSM Signal Quality Display	89
Figure 116:	LED-Matrix display network integration	89
Figure 117:	CS121MODBUS Installation	90
Figure 118:	CS121 PROFIBUS Installation	90
Figure 119:	UNMS-Installation	91
Figure 120:	MS-Timeservices	93
Figure 121:	Registry NTP Server	94
Figure 122:	Bash ntpd -b.....	95
Figure 123:	Bash ntp -b.....	96
Figure 124:	Runlevel	96
Figure 125:	Check Configuration.....	96
Figure 126:	Check Configuration.....	97
Figure 127:	NTP Query.....	98
Figure 128:	Mainboard Inform Pyramid DSP	98
Figure 129:	CS121 AlarmLog, ProtMan Connection	98
Figure 130:	CS121 Network Card Speed Configuration.....	Error! Bookmark not defined.
Figure 131:	Cable configuration HW121 COM2	101
Figure 132:	Cable configuration HW121/HW131 COM2	101
Figure 133:	External D-SUB 9-polig male	101
Figure 134:	Slot version: Circuit board connection	102
Figure 135:	Pin COM2 Mini-DIN 8 pol female.....	102
Figure 136:	AUX-Port (Hardware Revision 1.1 = from Serial numbers 0121-1203, 0122-00198, 0123-00564 onwards) RJ11 6-pol	102
Figure 137:	Example (Inputs): Opener or closer contact (only on hardware model CS121)	103
Figure 138:	Opto coupler logic	103
Figure 139:	Example (Outputs)	103
Figure 140:	Examples: AUX Input on hardware model CS131 only, left side "pull-down", right side "pull-up" configuration.....	104
Figure 141:	AUX Port Assignment.....	104
Figure 142:	CS121 WDP piggyboard installed on a CS121 SC/BSC – view from left and behind	105
Figure 143:	CS121 WDP connecting PINs on a CS121 SC/BSC board – top view.....	105
Figure 144:	MODBUS - Jumper	132
Figure 145:	MODBUS – CS121 COM2 Settings.....	132
Figure 146:	MODBUS - Cable 112.....	133
Figure 147:	SNMP Service Properties	140
Figure 148:	SNMP Trap Service.....	141
Figure 149:	General Properties	141
Figure 150:	Select a Monitor Type	142
Figure 151:	General Properties	143
Figure 152:	Configure the trap OIDs to collect.....	144
Figure 153:	Build Event Expression	144
Figure 154:	Configure the trap OIDs to collect.....	145
Figure 155:	Build Event Expression	146
Figure 156:	Configure Health.....	146
Figure 157:	Configure Alerts.....	147
Figure 158:	Discovery Method.....	148
Figure 159:	Telnet – DHCP Settings	149
Figure 160:	„pxout.bat“	150
Figure 161:	CS121 Configuration for such a relay command	151
Figure 162:	Raritan Device Settings.....	151
Figure 163:	Raritan SNMP Settings	152